

TECHNICAL GUIDE

SPLIT-SYSTEM AIR CONDITIONERS

13 SEER – R-410A – 1 PHASE

MODELS:

GCGD18 THRU 60

(1.5 THRU 5 NOMINAL TONS)



Due to continuous product improvement, specifications are subject to change without notice.

Visit us on the web at www.york.com

Additional rating information can be found at www.ahridirectory.org

WARRANTY

5-year limited parts warranty.
5-year limited compressor warranty.

DESCRIPTION

The 13 SEER Series unit is the outdoor part of a versatile climate system. It is designed with a matching indoor coil component from Johnson Controls Unitary Products. Available for typical applications this climate system is supported with accessories and documents to serve specific functions.

FEATURES

- **Quality Condenser Coils** - The coil is constructed of aluminum microchannel tubing and enhanced aluminum fins for increased efficiency.
- **Protected Compressor** - The compressor is internally protected against high pressure, temperature, and externally by a factory installed high pressure switch. This is accomplished by the simultaneous operation of high pressure relief valve and a temperature sensor which protects the compressor if undesirable operating conditions occur. A liquid line filter-drier further protects the compressor.
- **Durable Finish** - The cabinet is made of pre-painted steel. The pre-treated galvanized steel provides a better paint to steel bond, which resists corrosion and rust creep. Special primer formulas and matted-textured finish insure less fading when exposed to sunlight.
- **Lower Installed Cost** - Installation time and costs are reduced by easy power and control wiring connections. Available in sweat connect models only. The unit contains enough refrigerant for matching indoor coils and 15 feet of interconnecting piping. The small base dimension means less space is required on the ground or roof.
- **Top Discharge** - The warm air from the top mounted fan is blown up away from the structure and any landscaping. This allows compact location on multi-unit applications.
- **Low Operating Sound Level** - The upward air flow carries the normal operating noise away from the living area. The rigid top panel effectively isolates any motor sound. Isolator mounted compressor and the rippled fins of the condenser coil muffle the normal fan motor and compressor operating sounds.
- **Low Maintenance** - Long life permanently lubricated motor-bearings need no annual servicing.
- **Easy Service Access** - Fully exposed refrigerant connections, and a single panel covering the electrical controls make for easy servicing of the unit.
- **Secured Service Valves** - Secured re-usable service valves are provided on both the liquid and vapor sweat connections for ease of evacuating and charging.
- **U.L. and C.U.L. listed** - approved for outdoor application.
- **Agency Listed** - U.L. and C.U.L. listed - approved for outdoor application. The unit is certified in accordance with the Unitary Small Equipment certification program, which is based on AHRI Standard 210/240.

Physical and Electrical Data

MODEL		GCGD18 S41S3	GCGD24 S41S3	GCGD30 S41S3	GCGD36 S41S3	GCGD42 S41S3	GCGD48 S41S3	GCGD60 S41S3
Unit Supply Voltage		208-230V, 1 ϕ , 60Hz						
Normal Voltage Range ¹		187 to 252						
Minimum Circuit Ampacity		9.8	12.4	14.7	17.9	21.5	21.1	34.3
Max. Overcurrent Device Amps ²		15	20	25	30	35	35	60
Min. Overcurrent Device Amps ³		15	15	15	20	25	25	35
Compressor Type		Rotary	Recip	Recip	Recip	Recip	Recip	Scroll
Compressor Amps	Rated Load	7.4	9.3	10.6	13.1	16.0	15.7	26.2
	Locked Rotor	40	43	54	74	84	84	150
Crankcase Heater		No	No	No	No	No	No	No
Fan Motor Amps	Rated Load	0.5	0.8	1.4	1.5	1.5	1.5	1.5
Fan Diameter Inches		17.5	17.5	17.5	22	22	22	24
Fan Motor	Rated HP	1/12	1/8	1/4	1/4	1/4	1/4	1/4
	Nominal RPM	1100	1075	1100	850	850	850	850
	Nominal CFM	1400	1950	2050	3200	2950	2950	3600
Coil	Face Area Sq. Ft.	9.60	9.60	9.60	13.07	14.16	14.16	18.68
	Rows Deep	1	1	1	1	1	1	1
	Fin / Inches	23	23	23	23	23	23	23
Liquid Line Set OD (Field Installed)		3/8	3/8	3/8	3/8	3/8	3/8	3/8
Vapor Line Set OD (Field Installed)		5/8	3/4	3/4	3/4	7/8	7/8	7/8
Unit Charge (Lbs. - Oz.) ⁴		3 - 3	3 - 13	3 - 14	4 - 9	4 - 5	4 - 9	5 - 6
Charge Per Foot, Oz.		0.58	0.62	0.62	0.62	0.67	0.67	0.67
Operating Weight Lbs.		97	129	131	145	173	173	195

1. Rated in accordance with AHRI Standard 110, utilization range "A".

2. Dual element fuses or HACR circuit breaker. Maximum allowable overcurrent protection.

3. Dual element fuses or HACR circuit breaker. Minimum recommended overcurrent protection.

4. The Unit Charge is correct for the outdoor unit, matched indoor coil, and 15 feet of refrigerant tubing. For tubing lengths other than 15 feet, add or subtract the amount of refrigerant, using the difference in length multiplied by the per foot value.

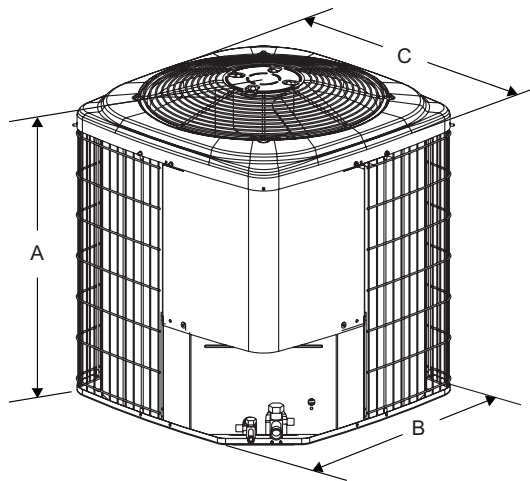

All dimensions are in inches. They are subject to change without notice. Certified dimensions will be provided upon request.

Unit Model	Dimensions (Inches)			Refrigerant Connection Service Valve Size	
	A ¹	B	C	Liquid	Vapor
18	28	23-1/2	23-1/2	3/8"	3/4"
24	28	23-1/2	23-1/2		
30	28	23-1/2	23-1/2		
36	28	29	29		
42	30	29	29		
48	30	29	29	7/8"	
60	32	33-5/8	33-5/8		

1. Including Fan Guard.

System Charge for Various Matched Systems							
Outdoor Unit	GCGD18 S41S3	GCGD24 S41S3	GCGD30 S41S3	GCGD36 S41S3	GCGD42 S41S3	GCGD48 S41S3	GCGD60 S41S3
Required Orifice or TXV ^{1,2}	.048/4F1	.055/4F1	.061/4F1	.065/4G1	.075/4G1	.073/4H1	.087/4J1
Factory Charge, lbs-oz	3 - 3	3 - 13	3 - 14	4 - 9	4 - 5	4 - 9	5 - 6
Indoor Coil ^{3,4}	Additional Charge, oz						
AHP18	0	-	-	-	-	-	-
AHP30	-	4	0	-	-	-	-
AHP36	-	-	2	0	-	-	-
AHP42	-	-	-	0	0	-	-
AHP60	-	-	-	-	-	0	0
AHR18	0	-	-	-	-	-	-
AHR24	-	4	-	-	-	-	-
AHR30	-	-	-	-	-	-	-
AHR36	-	-	2	0	-	-	-
AHR42	-	-	-	8	2	-	-
AHR48	-	-	-	-	-	0	-
AHR60	-	-	-	-	-	-	4
AHE18	0	-	-	-	-	-	-
AHE24	-	4	-	-	-	-	-
AHE30	-	4	0	-	-	-	-
AHE36	-	4	2	0	-	-	-
AHE42	-	-	-	8	2	-	-
AHE48	-	-	-	-	-	0	-
AHE60	-	-	-	-	-	-	4
AHX18	0	-	-	-	-	-	-
AHX30	-	4	0	-	-	-	-
AHX36	-	4	2	0	-	-	-
AHX42	-	-	-	8	2	-	-
AHX48	-	-	-	-	-	0	-
AHX60	-	-	-	-	-	-	4
AV*24	TXV + 0	-	-	-	-	-	-
AV*36	-	4	2	0	-	-	-
AV*48	-	-	-	-	TXV + 2	0	-
AV*60	-	-	-	-	TXV + 2	0	0
F4FP024	0	-	-	-	-	-	-
F4FP036	-	0	-	-	-	-	-
F4FP040	-	-	0	-	-	-	-
F4FV060	-	-	-	-	-	0	0
F5FP048	-	-	-	8	2	4	-
F5FP060	-	-	-	-	-	0	0
F6FP018	0	-	-	-	-	-	-
F6FP030	-	4	0	-	-	-	-
F6FP036	-	4	0	-	-	-	-
F6FP042	-	-	-	8	2	-	-
F6FP048	-	-	-	-	TXV + 2	0	-
F6FP060	-	-	-	-	-	-	4
FC/MC/PC18	0	-	-	-	-	-	-
FC/MC/PC32	-	4	0	-	-	-	-
FC/MC/PC35	-	4	0	-	-	-	-
FC/MC/PC36	-	0	-	-	-	-	-
FC/MC/PC37	-	4	2	0	-	-	-

For Notes See Page 4.

System Charge for Various Matched Systems (Continued)							
Outdoor Unit	GCGD18 S41S3	GCGD24 S41S3	GCGD30 S41S3	GCGD36 S41S3	GCGD42 S41S3	GCGD48 S41S3	GCGD60 S41S3
Required Orifice or TXV ^{1,2}	.048/4F1	.055/4F1	.061/4F1	.065/4G1	.075/4G1	.073/4H1	.087/4J1
Factory Charge, lbs-oz	3 - 3	3 - 13	3 - 14	4 - 9	4 - 5	4 - 9	5 - 6
Indoor Coil ^{3,4}	Additional Charge, oz						
FC/MC/PC43	–	4	2	0	0	–	–
FC/MC/PC48	–	–	–	8	2	4	–
FC/MC/PC60	–	–	–	–	–	0	0
FC/MC62	–	–	–	–	–	–	4
FC64	–	–	–	–	–	–	11
UC18	0	–	–	–	–	–	–
UC36	–	0	–	–	–	–	–
UC48	–	–	–	8	2	4	–
UC60	–	–	–	–	–	0	0

FOOTNOTES:

1. For applications requiring a TXV use 1TVM series kit.
2. Approved orifice shipped with outdoor unit.
3. Systems matched with furnace or air handlers not equipped with blower-off delays may require blower Time Delay Kit 2FD06700224.
4. PC coils cannot be used in downflow or horizontal applications. FC coils cannot be used in horizontal applications.

PROCEDURES:

1. Unit factory charge listed on the unit nameplate includes refrigerant for the condenser, the smallest evaporator, and 15 feet of interconnecting line tubing.
2. Verify the TXV and additional charge required for specific evaporator coil in the system using the above table.
3. Additional charge for the amount of interconnecting line tubing greater than 15 feet at the rate specified in Physical and Electrical Data Table.
4. For orifice or TXV matches requiring additional charge, the refrigerant needs to be weighed in for specific coil match and lineset length.
5. Permanently mark the unit nameplate with the total system charge. Total System Charge = Base Charge (as shipped) + adder for evaporator + adder for line set.

IMPORTANT

Models 12-48 require start kits for TXV matches.

COOLING CAPACITY - With Air Handler Coils

UNIT MODEL	AIR HANDLER		COIL MODEL ¹	COOLING					
	MODEL	W		RATED CFM	NET MBH		SEER	EER	
					TOTAL	SENS.			
13 SEER AC WITH MV - VARIABLE SPEED									
GCGD18S41S3	MV12B	17	FC/MC18B	600	17.5	13.3	14.00	12.50	
GCGD24S41S3	MV12B	17	FC/MC36B	800	24.0	17.4	14.00	12.00	
	MV12B	17	FC/MC35B	800	24.0	17.4	14.00	12.00	
GCGD30S41S3	MV12B	17	FC/MC43B	800	24.0	17.3	14.00	12.00	
	MV12B	17	FC/MC35B	1000	29.0	21.6	14.00	12.00	
	MV16C	21	FC/MC35C	1000	30.0	21.6	14.00	12.00	
	MV12B	17	FC/MC43B	1000	29.0	21.6	14.00	12.00	
GCGD36S41S3	MV16C	21	FC/MC43C	1000	30.0	21.6	14.00	12.00	
	MV12B	17	FC/MC43B	1225	35.4	25.2	14.00	11.75	
	MV16C	21	FC/MC43C	1200	36.0	25.4	14.00	12.00	
	MV16C	21	FC/MC48C	1200	36.0	25.4	14.00	12.00	
	MV20D	24	FC/MC48D	1200	36.0	25.6	14.00	12.00	
GCGD42S41S3	MV12D	24	FC/MC48D	1135	35.0	25.4	14.00	12.00	
	MV16C	21	FC/MC43C	1400	42.0	30.0	13.50	12.00	
	MV16C	21	FC/MC48C	1400	42.0	30.0	13.50	12.00	
GCGD48S41S3	MV20D	24	FC/MC48D	1400	42.0	30.0	14.00	12.00	
	MV16C	21	FC/MC48C	1600	48.0	35.0	13.50	12.00	
	MV20D	24	FC/MC48D	1600	48.0	35.0	13.50	12.00	
	MV16C	21	FC/PC60C	1625	47.5	34.4	13.50	11.50	
GCGD60S41S3	MV20D	24	FC/MC60D	1600	48.0	35.0	13.50	12.00	
	MV20D	24	FC/MC60D	1800	57.0	38.5	13.00	11.00	
	MV20D	24	FC/MC62D	1800	57.0	38.5	13.00	11.00	
GCGD60S41S3	MV20D	24	FC64D	1855	57.0	39.0	13.75	11.50	
	13 SEER AC WITH MX - VARIABLE SPEED								
	GCGD18S41S3	MX12B	17	FC/MC18B	585	17.9	13.5	14.75	12.50
GCGD24S41S3	MX12B	17	FC/MC35B	815	24.8	17.4	15.00	12.50	
	MX12B	17	FC/MC36B	745	24.2	16.9	14.75	12.25	
GCGD30S41S3	MX12B	17	FC/MC43B	735	24.6	17.1	14.75	12.50	
	MX12B	17	FC/MC35B	1085	30.0	22.6	14.25	12.00	
	MX16C	21	FC/MC35C	1035	30.0	22.2	14.75	12.50	
	MX12B	17	FC/MC43B	1095	30.4	23.0	14.50	12.25	
GCGD36S41S3	MX16C	21	FC/MC43C	970	30.2	21.8	15.00	12.50	
	MX12B	17	FC/MC43B	1220	35.4	25.2	13.75	11.75	
	MX16C	21	FC/MC43C	1140	35.4	25.0	14.50	12.25	
	MX12D	24	FC/MC48D	1225	36.0	25.6	14.25	12.25	
GCGD42S41S3	MX16C	21	FC/MC48C	1150	36.2	25.6	14.75	12.50	
	MX16C	21	FC/MC43C	1365	42.5	30.0	14.25	12.00	
	MX16C	21	FC/MC48C	1390	43.0	30.4	14.50	12.25	
GCGD48S41S3	MX20D	24	FC/MC48D	1415	43.0	30.2	14.50	12.00	
	MX16C	21	FC/MC48C	1685	48.5	35.6	13.75	11.50	
	MX20D	24	FC/MC48D	1525	48.0	34.2	14.00	11.75	
	MX16C	21	FC/PC60C	1630	48.5	34.6	14.00	11.75	
GCGD60S41S3	MX20D	24	FC/MC60D	1585	48.5	34.6	14.00	12.00	
	MX20D	24	FC/MC60D	1780	57.5	38.8	13.75	11.50	
	MX20D	24	FC/MC62D	1795	58.0	38.8	14.00	11.75	
GCGD60S41S3	MX20D	24	FC64D	1795	58.5	39.8	14.50	12.00	

For Notes See Page 7.

COOLING CAPACITY - With Air Handler Coils (Continued)

UNIT MODEL	AIR HANDLER		COIL MODEL ¹	COOLING				
	MODEL	W		RATED CFM	NET MBH		SEER	EER
					TOTAL	SENS.		
13 SEER AC WITH AV / F*FV - VARIABLE SPEED								
GCGD18S41S3	AV*24	17	–	610	18.0	13.5	14.50	12.00
GCGD24S41S3	AV*36	21	–	725	24.0	17.4	14.00	12.00
GCGD30S41S3	AV*36	21	–	960	30.0	21.8	14.50	12.00
GCGD36S41S3	AV*36	21	–	1190	35.0	25.2	14.00	12.00
GCGD42S41S3	AV*48	24	–	1385	42.0	29.8	14.00	12.00
	AV*60	24	–	1360	42.0	29.8	14.00	12.00
GCGD48S41S3	AV*48	24	–	1625	48.0	35.0	13.50	12.00
	AV*60	24	–	1560	48.0	35.0	13.50	12.00
	F4FV060	24	–	1600	48.0	34.6	14.00	11.50
GCGD60S41S3	AV*60	24	–	1730	58.0	39.0	13.50	11.00
	F4FV060	24	–	1780	57.0	38.5	13.50	11.00
13 SEER AC WITH AHE / AHP / AHR / AHX / F*FP								
GCGD18S41S3	AHE18	17	–	610	17.9	13.8	14.75	12.25
	AHP18	17	–	650	17.5	12.9	13.00	11.00
	AHR18	17	–	665	17.8	13.8	13.00	11.00
	AHX18	17	–	630	18.0	13.8	14.50	12.00
	F4FP024	18	–	600	17.5	12.9	13.00	11.00
	F6FP018	17	–	600	17.8	13.3	14.50	12.00
GCGD24S41S3	AHE24	17	–	795	24.4	17.4	14.50	12.00
	AHE30	17	–	795	24.4	17.4	14.50	12.00
	AHE36	21	–	855	25.2	18.5	15.00	12.50
	AHP30	17	–	795	24.0	16.8	13.00	11.00
	AHR24	17	–	740	23.8	16.5	13.00	11.00
	AHX30	17	–	820	24.0	16.9	14.50	12.00
	AHX36	21	–	815	24.0	16.9	14.50	12.00
	F4FP036	21.5	–	855	24.0	16.7	13.00	11.00
	F6FP030	17	–	850	24.0	16.8	14.00	11.80
	F6FP036	21	–	855	24.0	17.0	14.00	12.00
GCGD30S41S3	AHE30	17	–	985	29.4	21.4	14.00	11.75
	AHE36	21	–	1000	30.2	22.0	14.75	12.25
	AHP30	17	–	1015	29.0	21.0	13.00	11.00
	AHP36	21	–	1040	29.0	21.0	13.00	11.00
	AHR30	17	–	1095	29.4	22.2	13.00	11.00
	AHR36	21	–	1060	29.8	22.0	13.00	11.00
	AHX30	17	–	1025	29.4	22.2	14.00	11.75
	AHX36	21	–	1005	30.0	22.3	14.50	12.00
	F4FP040	18	–	1050	29.0	21.0	13.00	11.00
	F6FP030	17	–	1035	29.2	21.6	13.60	11.40
F6FP036	21	–	980	29.4	21.4	14.00	12.00	
GCGD36S41S3	AHE36	21	–	1190	35.6	25.4	14.25	12.00
	AHE42	21	–	1180	35.8	25.8	14.50	12.25
	AHP36	21	–	1235	35.0	24.8	13.00	11.00
	AHP42	21	–	1255	35.0	24.8	13.00	11.00
	AHR36	21	–	1245	34.6	24.6	13.00	11.00
	AHR42	21	–	1230	35.6	25.4	13.00	11.25
	AHX36	21	–	1225	35.2	25.0	13.50	11.50
	AHX42	21	–	1190	35.4	25.2	14.00	11.80
	F5FP048	24	–	1235	35.0	24.8	13.00	11.00
F6FP042	21	–	1290	35.8	25.8	13.50	11.50	

For Notes See Page 7.

COOLING CAPACITY - With Air Handler Coils (Continued)

UNIT MODEL	AIR HANDLER		COIL MODEL ¹	COOLING				
	MODEL	W		RATED CFM	NET MBH		SEER	EER
					TOTAL	SENS.		
13 SEER AC WITH AHE / AHP / AHR / AHX / F*FP (Continued)								
GCGD42S41S3	AHE42	21	—	1385	43.0	30.4	14.50	12.00
	AHP42	21	—	1485	41.0	29.2	13.00	11.00
	AHR42	21	—	1485	42.5	30.6	13.00	11.00
	AHX42	21	—	1395	42.0	29.9	14.50	12.00
	F5FP048	24	—	1455	41.0	29.2	13.00	11.00
	F6FP042	21	—	1455	42.0	30.1	14.00	11.75
	F6FP048	24	—	1380	41.5	29.4	13.50	11.70
GCGD48S41S3	AHE48	24	—	1600	47.0	34.6	13.75	11.50
	AHP48	24	—	1675	48.0	34.4	13.00	11.00
	AHP60	24	—	1600	48.0	35.0	13.50	11.00
	AHR48	24	—	1610	48.0	34.6	13.00	11.00
	AHX48	24	—	1660	48.0	35.4	13.50	11.50
	F5FP048	24	—	1600	48.0	34.4	13.00	11.00
	F5FP060	24	—	1600	48.0	34.4	13.00	11.00
	F6FP048	24	—	1625	47.0	34.8	13.00	11.30
GCGD60S41S3	AHE60	24	—	1835	58.5	39.8	13.50	11.50
	AHP60	24	—	1850	57.0	38.5	13.00	11.00
	AHR60	24	—	1870	57.0	38.5	13.00	11.00
	AHX60	24	—	1905	58.5	40.0	13.50	11.50
	F5FP060	24	—	1900	57.0	38.5	13.00	11.00
	F6FP060	24	—	1710	57.5	39.0	13.50	11.50

Rated in accordance with DOE test procedures (Federal Register 12-27-79 and 3-18-88) and AHRI Standards 210. Cooling MBH based on 80 °F entering air temperature, 50% RH, and rated air flow.

EER (Energy Efficiency Ratio) is the total cooling output in BTU's at 95 °F outdoor ambient divided by the total electric power in watt-hours at those conditions.

SEER (Seasonal Energy Efficiency Ratio) is the total cooling output in BTU's during a normal annual usage period for cooling divided by the total electric power input in watt-hours during the same period.

1. MC coils available with a factory installed horizontal drain pan. See price pages for specific model number.

— = Not applicable.

MA Modular Air Handlers use coil only ratings.

COOLING CAPACITY - Upflow, Downflow & Horizontal Furnaces and Coils

UNIT MODEL	FURNACE**		COIL MODEL	COOLING				
	CFM RANGE (Min.-max.)	W		RATED CFM	NET MBH		SEER ¹	EER
					TOTAL	SENS.		
GCGD18S41S3	450 - 750	14,17	FC/MC/PC18	600	17.5	12.9	13.00	11.00
	450 - 750	14,17	UC18	600	17.5	12.9	13.00	11.00
GCGD24S41S3	600 - 1000	14	FC/MC/PC32	800	24.0	16.7	13.00	11.00
	600 - 1000	17,21	FC/MC/PC35	800	24.0	16.7	13.00	11.00
	600 - 1000	14,17,21	FC/MC/PC36	800	24.0	16.7	13.00	11.00
	600 - 1000	14	FC/MC/PC37	800	24.0	16.7	13.00	11.00
	600 - 1000	17,21	FC/MC/PC43	800	24.0	16.7	13.00	11.00
	600 - 1000	14,17,21	UC36	800	24.0	16.7	13.00	11.00
GCGD30S41S3	800 - 1200	14	FC/MC/PC32	1000	29.0	21.0	13.00	11.00
	800 - 1200	17,21	FC/MC/PC35	1000	29.0	21.0	13.00	11.00
	800 - 1200	14	FC/MC/PC37	1000	29.0	21.0	13.00	11.00
	800 - 1200	17,21	FC/MC/PC43	1000	29.0	21.0	13.00	11.00
GCGD36S41S3	1000 - 1400	14	FC/MC/PC37	1200	35.0	24.8	13.00	11.00
	1000 - 1400	17,21	FC/MC/PC43	1200	35.0	24.8	13.00	11.00
	1000 - 1400	21,24	FC/MC/PC48	1200	35.0	24.8	13.00	11.00
	1000 - 1400	21,24	UC48	1200	35.0	24.8	13.00	11.00
GCGD42S41S3	1200 - 1600	17,21	FC/MC/PC43	1400	42.0	29.2	13.00	11.00
	1200 - 1600	21,24	FC/MC/PC48	1400	42.0	29.2	13.00	11.00
	1200 - 1600	21,24	UC48	1400	42.0	29.2	13.00	11.00
GCGD48S41S3	1400 - 1800	21,24	FC/MC/PC48	1600	48.0	34.4	13.00	11.00
	1400 - 1800	21,24	FC/MC/PC60	1600	48.0	34.4	13.00	11.00
	1400 - 1800	21,24	UC48	1600	48.0	34.4	13.00	11.00
	1400 - 1800	21,24	UC60	1600	48.0	34.4	13.00	11.00
GCGD60S41S3	1600 - 2000	21,24	FC/MC/PC60	1800	57.0	38.5	13.00	11.00
	1600 - 2000	24	FC/MC62	1800	57.0	38.5	13.00	11.00
	1600 - 2000	24	FC64	1800	57.0	39.0	13.50	11.25
	1600 - 2000	21,24	UC60	1800	57.0	38.5	13.00	11.00

1. Requires a 2FD06700224 Blower Time Delay unless a standard furnace is equipped with one.

** Refer to Quick Selection Chart for specific furnace match-up.

COOLING CAPACITY - With High Efficiency Motor Furnaces

MODELS	FURNACE MODEL	COIL MODEL ¹	W	COOLING				
				RATED CFM	Net MBH		SEER	EER
					TOTAL	SENS.		
13 SEER HP WITH VARIABLE SPEED FURNACES²								
GCGD18S41S3	T*(8,L)X*A12	FC/MC/PC18A	14	540	17.7	12.9	14.50	12.50
	T*(8,L)X*B12	FC/MC/PC18B	17	580	18.0	13.4	14.50	12.50
	T*9X*B12	FC/MC/PC18B	17	590	18.0	13.4	14.50	12.50
	T*(8,L)X*A12	UC18A	14	590	18.0	13.4	14.50	12.00
	T*(8,L)X*B12	UC18B	17	595	18.0	13.4	14.50	12.00
	T*9X*B12	UC18B	17	590	18.0	13.4	14.50	12.00
	(T*(8,L)C/T*8V)*A12	FC/MC/PC18A	14	620	17.5	12.7	14.50	12.50
	(T*(8,L)C/T*8V)*B12	FC/MC/PC18B	17	580	17.5	12.6	14.50	12.00
	(T*9C/T*9V)*B12	FC/MC/PC18B	17	610	17.5	12.8	14.50	12.50
	(T*(8,L)C/T*8V)*A12	UC18A	14	620	17.5	12.7	14.50	12.00
	(T*(8,L)C/T*8V)*B12	UC18B	17	580	17.5	12.5	14.50	12.00
(T*9C/T*9V)*B12	UC18B	17	610	17.5	12.6	14.50	12.50	
GCGD24S41S3	T*(8,L)X*A12	FC/MC/PC32A	14	800	24.0	16.9	14.00	11.50
	T*(8,L)X*B12	FC/MC/PC35B	17	850	24.0	17.0	14.00	12.00
	T*9X*C16	FC/MC/PC35C	21	715	23.8	16.3	14.00	12.00
	T*9X*C20	FC/MC/PC35C	21	825	24.0	17.0	14.00	12.00
	T*(8,L)X*A12	FC/MC/PC36A	14	815	24.0	16.8	14.00	12.00
	T*(8,L)X*B12	FC/MC/PC36B	17	835	24.0	16.8	14.00	12.00
	T*9X*B12	FC/MC/PC36B	17	775	24.0	16.8	14.00	12.00
	T*9X*C16	FC/MC/PC36C	21	770	24.0	16.8	14.00	12.00
	T*9X*C20	FC/MC/PC36C	21	810	24.0	16.8	14.00	12.00
	T*(8,L)X*A12	FC/MC/PC37A	14	840	24.0	17.0	14.00	12.00
	T*(8,L)X*B12	FC/MC/PC43B	17	865	24.0	17.0	14.00	12.00
	(T*(8,L)C/T*8V)*A12	FC/MC/PC32A	14	775	24.0	17.0	14.00	11.50
	(T*(8,L)C/T*8V)*B12	FC/MC/PC35B	17	760	24.0	16.8	14.00	12.00
	(T*9C/T*9V)*B12	FC/MC/PC35B	17	815	24.0	17.1	14.00	12.00
	(T*(8,L)C/T*8V)*A12	FC/MC/PC36A	14	805	24.0	16.9	14.00	12.00
	(T*(8,L)C/T*8V)*B12	FC/MC/PC36B	17	765	24.0	17.0	14.00	12.00
	(T*9C/T*9V)*B12	FC/MC/PC36B	17	815	24.0	16.9	14.00	12.00
	(T*(8,L)C/T*8V)*A12	FC/MC/PC37A	14	805	24.0	17.0	14.00	12.00
	(T*(8,L)C/T*8V)*B12	FC/MC/PC43B	17	760	24.0	16.9	14.00	12.00
	(T*9C/T*9V)*B12	FC/MC/PC43B	17	800	24.0	17.0	14.00	12.00
	(T*(8,L)C/T*8V)*A12	UC36A	14	805	23.6	16.6	13.80	11.50
(T*(8,L)C/T*8V)*B12	UC36B	17	765	23.6	16.7	14.00	11.50	
(T*9C/T*9V)*B12	UC36B	17	815	23.6	16.7	13.80	11.50	
GCGD30S41S3	T*(8,L)X*A12	FC/MC/PC32A	14	970	29.2	21.4	13.20	11.00
	T*(8,L)X*B12	FC/MC/PC35B	17	1120	30.0	22.8	14.00	11.50
	T*(8,L)X*C16	FC/MC/PC35C	21	1105	30.0	22.8	14.00	12.00
	T*(8,L)X*C20	FC/MC/PC35C	21	850	28.8	20.6	14.00	12.00
	T*9X*B12	FC/MC/PC35B	17	1085	29.8	22.8	14.00	12.00
	T*9X*C16	FC/MC/PC35C	21	1075	29.8	22.4	14.00	12.00
	T*(8,L)X*A12	FC/MC/PC37A	14	1105	30.0	22.9	13.80	11.50
	T*(8,L)X*B12	FC/MC/PC43B	17	1125	30.0	22.9	14.00	12.00
	T*(8,L)X*C16	FC/MC/PC43C	21	710	28.2	19.3	14.00	12.00
	T*(8,L)X*C20	FC/MC/PC43C	21	870	29.6	21.2	14.00	12.00
	T*9X*B12	FC/MC/PC43B	17	1095	30.0	22.9	13.80	11.50
	T*9X*C16	FC/MC/PC43C	21	1055	30.0	22.9	14.00	12.00
	T*9X*C20	FC/MC/PC43C	21	720	28.2	19.3	14.00	12.00

For Notes See Page 12.

COOLING CAPACITY - With High Efficiency Motor Furnaces (Continued)

MODELS	FURNACE MODEL	COIL MODEL ¹	W	COOLING				
				RATED CFM	Net MBH		SEER	EER
					TOTAL	SENS.		
13 SEER HP WITH VARIABLE SPEED FURNACES²								
GCGD30S41S3	(T*(8,L)C/T*8V)*A12	FC/MC/PC32A	14	1045	29.2	21.8	13.20	11.00
	(T*(8,L)C/T*8V)*B12	FC/MC/PC35B	17	995	29.6	21.4	14.00	11.50
	(T*9C/T*9V)*B12	FC/MC/PC35B	17	1045	29.4	22.0	13.50	11.50
	(T*(8,L)C/T*8V)*C16	FC/MC/PC35C	21	1025	29.6	22.0	14.00	12.00
	(T*(8,L)C/T*8V)*C20	FC/MC/PC35C	21	1080	30.0	22.4	14.00	12.00
	(T*9C/T*9V)*C16	FC/MC/PC35C	21	1005	29.6	22.0	14.00	12.00
	(T*9C/T*9V)*C20	FC/MC/PC35C	21	985	29.6	22.0	14.00	12.00
	(T*(8,L)C/T*8V)*A12	FC/MC/PC37A	14	980	29.8	21.8	13.80	11.50
	(T*(8,L)C/T*8V)*B12	FC/MC/PC43B	17	990	30.0	22.0	14.00	12.00
	(T*9C/T*9V)*B12	FC/MC/PC43B	17	1035	30.0	22.0	13.80	11.50
	(T*(8,L)C/T*8V)*C16	FC/MC/PC43C	21	990	30.0	22.1	14.00	12.00
	(T*(8,L)C/T*8V)*C20	FC/MC/PC43C	21	1000	30.0	22.1	14.00	12.00
	(T*9C/T*9V)*C16	FC/MC/PC43C	21	1030	30.0	22.0	14.00	12.00
	(T*9C/T*9V)*C20	FC/MC/PC43C	21	995	30.0	22.1	14.00	12.00
GCGD36S41S3	T*(8,L)X*A12	FC/MC/PC37A	14	1290	35.2	25.4	13.30	11.25
	T*(8,L)X*B12	FC/MC/PC43B	17	1300	35.2	25.4	13.30	11.25
	T*(8,L)X*C16	FC/MC/PC43C	21	1175	35.2	24.8	14.00	11.50
	T*(8,L)X*C20	FC/MC/PC43C	21	1250	35.6	25.6	13.80	11.70
	T*9X*B12	FC/MC/PC43B	17	1270	35.2	25.4	13.25	11.25
	T*9X*C16	FC/MC/PC43C	21	1260	35.4	25.4	13.45	11.40
	T*9X*C20	FC/MC/PC43C	21	1185	35.0	24.6	13.55	11.40
	T*(8,L)X*C16	FC/MC/PC48C	21	1185	35.6	25.2	14.00	11.50
	T*(8,L)X*C20	FC/MC/PC48C	21	1270	35.8	25.8	14.00	11.50
	T*9X*C16	FC/MC/PC48C	21	1280	35.8	25.8	13.70	11.50
	T*9X*C20	FC/MC/PC48C	21	1205	35.4	25.0	13.70	11.50
	T*9X*D20	FC/MC/PC48D	24	1240	35.4	25.0	13.70	11.50
	T*(8,L)X*C16	UC48C	21	1185	34.2	24.8	13.50	11.50
	T*(8,L)X*C20	UC48C	21	1300	34.8	25.4	13.50	11.50
	T*9X*C16	UC48C	21	1280	34.6	24.8	13.15	11.20
	T*9X*C20	UC48C	21	1205	34.0	24.6	13.25	11.20
	T*9X*D20	UC48D	24	1240	34.0	24.6	13.30	11.25
	(T*(8,L)C/T*8V)*A12	FC/MC/PC37A	14	980	33.8	23.0	13.50	11.00
	(T*(8,L)C/T*8V)*B12	FC/MC/PC43B	17	1210	35.2	25.2	13.50	11.00
	(T*9C/T*9V)*B12	FC/MC/PC43B	17	1200	35.2	25.2	13.50	11.00
	(T*(8,L)C/T*8V)*C16	FC/MC/PC43C	21	1205	35.6	25.4	14.00	11.50
	(T*(8,L)C/T*8V)*C20	FC/MC/PC43C	21	1190	35.6	25.4	14.00	12.00
	(T*9C/T*9V)*C16	FC/MC/PC43C	21	1240	35.4	25.2	13.50	11.50
	(T*9C/T*9V)*C20	FC/MC/PC43C	21	1200	35.6	25.4	14.00	11.50
	(T*(8,L)C/T*8V)*C16	FC/MC/PC48C	21	1210	36.0	26.0	14.00	12.00
	(T*(8,L)C/T*8V)*C20	FC/MC/PC48C	21	1155	36.0	26.1	14.00	12.00
	(T*9C/T*9V)*C16	FC/MC/PC48C	21	1195	36.0	26.0	14.00	11.50
	(T*9C/T*9V)*C20	FC/MC/PC48C	21	1330	36.0	26.5	14.00	11.50
	(T*9C/T*9V)*D20	FC/MC/PC48D	24	1240	36.0	26.2	14.00	12.00
	(T*(8,L)C/T*8V)*C16	UC48C	21	1210	34.6	24.8	13.50	11.50
	(T*(8,L)C/T*8V)*C20	UC48C	21	1155	34.8	24.8	14.00	11.50
	(T*9C/T*9V)*C16	UC48C	21	1195	34.6	24.8	13.50	11.50
(T*9C/T*9V)*C20	UC48C	21	1305	35.0	25.6	13.30	11.00	
(T*9C/T*9V)*D20	UC48D	24	1240	34.8	25.0	13.80	11.50	

For Notes See Page 12.

COOLING CAPACITY - With High Efficiency Motor Furnaces (Continued)

MODELS	FURNACE MODEL	COIL MODEL ¹	W	COOLING				
				RATED CFM	Net MBH		SEER	EER
					TOTAL	SENS.		
13 SEER HP WITH VARIABLE SPEED FURNACES²								
GCGD42S41S3	T*(8,L)X*B12	FC/MC/PC43B	17	1300	42.0	29.0	13.50	11.50
	T*(8,L)X*C16	FC/MC/PC43C	21	1475	42.0	29.9	13.50	11.50
	T*(8,L)X*C20	FC/MC/PC43C	21	1415	42.0	29.5	13.50	11.50
	T*9X*B12	FC/MC/PC43B	17	1270	42.0	29.0	13.50	11.50
	T*9X*C16	FC/MC/PC43C	21	1410	42.0	29.6	13.30	11.00
	T*9X*C20	FC/MC/PC43C	21	1400	42.0	29.6	13.50	11.00
	T*(8,L)X*C16	FC/MC/PC48C	21	1360	42.0	29.5	13.80	11.50
	T*(8,L)X*C20	FC/MC/PC48C	21	1475	42.0	30.1	14.00	11.50
	T*9X*C16	FC/MC/PC48C	21	1425	42.0	29.3	13.50	11.50
	T*9X*C20	FC/MC/PC48C	21	1420	42.0	29.3	13.50	11.50
	T*9X*D20	FC/MC/PC48D	24	1435	42.0	29.7	13.50	11.50
	T*(8,L)X*C16	UC48C	21	1400	42.0	29.4	13.50	11.00
	T*(8,L)X*C20	UC48C	21	1515	42.0	30.0	13.50	11.00
	T*9X*C16	UC48C	21	1425	41.5	29.2	13.30	11.00
	T*9X*C20	UC48C	21	1420	42.0	29.4	13.20	11.00
	T*9X*D20	UC48D	24	1435	42.0	29.4	13.40	11.00
	(T*(8,L)C/T*8V)*C16	FC/MC/PC43C	21	1425	42.0	30.0	13.50	11.50
	(T*(8,L)C/T*8V)*C20	FC/MC/PC43C	21	1450	42.0	30.4	13.50	11.50
	(T*9C/T*9V)*C16	FC/MC/PC43C	21	1360	42.0	29.6	13.30	11.00
	(T*9C/T*9V)*C20	FC/MC/PC43C	21	1395	42.0	29.6	13.50	11.00
	(T*(8,L)C/T*8V)*C16	FC/MC/PC48C	21	1435	42.0	30.1	13.80	11.50
	(T*(8,L)C/T*8V)*C20	FC/MC/PC48C	21	1410	42.0	30.1	14.00	11.50
	(T*9C/T*9V)*C16	FC/MC/PC48C	21	1395	42.0	30.3	13.50	11.50
	(T*9C/T*9V)*C20	FC/MC/PC48C	21	1430	42.0	30.3	13.50	11.50
	(T*9C/T*9V)*D20	FC/MC/PC48D	24	1450	42.0	29.9	13.80	11.50
	(T*(8,L)C/T*8V)*C16	UC48C	21	1435	41.5	30.2	13.50	11.00
	(T*(8,L)C/T*8V)*C20	UC48C	21	1410	41.5	30.2	13.50	11.50
	(T*9C/T*9V)*C16	UC48C	21	1395	41.5	30.2	13.30	11.00
(T*9C/T*9V)*C20	UC48C	21	1430	41.5	30.0	13.20	11.00	
(T*9C/T*9V)*D20	UC48D	24	1450	41.5	30.2	13.40	11.00	
GCGD48S41S3	T*(8,L)X*C16	FC/MC/PC48C	21	1600	48.0	34.4	13.30	11.00
	T*(8,L)X*C20	FC/MC/PC48C	21	1660	48.0	34.4	13.20	11.00
	T*9X*C16	FC/MC/PC48C	21	1565	48.0	34.8	13.10	11.00
	T*9X*C20	FC/MC/PC48C	21	1615	48.0	34.4	13.20	11.00
	T*9X*D20	FC/MC/PC48D	24	1635	48.0	34.8	13.20	11.00
	T*(8,L)X*C16	FC/PC60C	21	1605	48.0	34.6	13.30	11.00
	T*(8,L)X*C20	FC/MC/PC60D	21	1595	48.0	34.8	13.30	11.00
	T*9X*C16	FC/PC60C	21	1575	47.0	34.6	13.10	11.00
	T*9X*C20	FC/PC60C	21	1625	47.0	34.6	13.10	11.00
	T*9X*D20	FC/MC/PC60D	24	1490	47.5	33.8	13.20	11.00
	(T*(8,L)C/T*8V)*C16	FC/MC/PC48C	21	1565	48.0	35.0	13.30	11.00
	(T*(8,L)C/T*8V)*C20	FC/MC/PC48C	21	1640	48.0	35.0	13.20	11.00
	(T*9C/T*9V)*C16	FC/MC/PC48C	21	1590	48.0	34.6	13.10	11.00
	(T*9C/T*9V)*C20	FC/MC/PC48C	21	1655	48.0	34.8	13.20	11.00
	(T*9C/T*9V)*D20	FC/MC/PC48D	24	1645	48.0	35.2	13.20	11.00
	(T*9C/T*9V)*D20	FC/MC/PC60D	24	1615	48.0	35.0	13.20	11.00
	(T*(8,L)C/T*8V)*C16	FC/PC60C	21	1600	48.0	35.0	13.30	11.00
	(T*(8,L)C/T*8V)*C20	FC/PC60C	21	1625	48.0	35.0	13.50	11.50
	(T*9C/T*9V)*C16	FC/PC60C	21	1590	48.0	35.2	13.10	11.00
	(T*9C/T*9V)*C20	FC/PC60C	21	1655	48.0	35.2	13.10	11.00

For Notes See Page 12.

COOLING CAPACITY - With High Efficiency Motor Furnaces (Continued)

MODELS	FURNACE MODEL	COIL MODEL ¹	W	COOLING				
				RATED CFM	Net MBH		SEER	EER
					TOTAL	SENS.		
13 SEER HP WITH VARIABLE SPEED FURNACES²								
GCGD60S41S3	T*(8,L)X*C16	FC/PC60C	21	1605	56.5	37.8	13.50	11.00
	T*(8,L)X*C20	FC/MC/PC60D	21	1690	57.0	37.8	13.50	11.00
	T*9X*D20	FC/MC/PC60D	24	1630	56.5	37.8	13.30	11.00
	T*9X*C20	FC/MC/PC60D	21	1645	56.5	37.8	13.30	11.00
	T*(8,L)X*C20	FC/MC62D	21	1665	57.0	37.8	13.50	11.00
	T*(8,L)X*C16	UC60C	21	1640	56.0	37.2	13.00	11.00
	T*(8,L)X*C20	UC60D	21	1735	56.5	38.5	13.00	11.00
	T*9X*C16	FC/PC60C	21	1575	56.0	37.2	13.00	11.00
	T*9X*C20	FC/PC60C	21	1560	56.0	37.2	13.00	11.00
	T*9X*D20	UC60D	24	1630	56.0	37.2	13.00	11.00
	T*(8,L)X*C20	UC60D	21	1735	56.5	38.5	13.00	11.00
	T*9X*C20	UC60D	21	1645	56.0	37.2	13.00	11.00
	(T*9C/T*9V)*D20	FC/MC/PC60D	24	1615	55.5	36.8	13.30	11.00
	(T*(8,L)C/T*8V)*C20	FC/MC62D	21	1615	56.5	37.4	13.50	11.00
	(T*9C/T*9V)*C20	FC/MC62D	21	1655	56.0	37.2	13.20	11.00
	(T*9C/T*9V)*D20	FC/MC62D	24	1630	56.0	37.4	13.30	11.00
	(T*(8,L)C/T*8V)*C20	FC/PC60C	21	1605	55.5	37.0	13.50	11.00
	(T*9C/T*9V)*C20	FC/PC60C	21	1655	55.0	36.8	13.30	11.00
	(T*(8,L)C/T*8V)*C20	UC60C	21	1605	54.0	35.2	13.00	11.00
	(T*9C/T*9V)*C20	UC60C	21	1655	53.5	35.0	13.00	10.80
(T*9C/T*9V)*D20	UC60D	24	1615	53.5	35.0	13.00	10.90	

1. MC coils available with a factory installed horizontal drain pan. See price pages for specific model number.

2. Variable speed furnaces have B.O.D (Blower on Delay) standard.

ACCESSORIES

Refer to Price Manual for specific model numbers.

Off Cycle Timer Delay - Provides a 5-minute off cycle to prevent rapid recycling of the compressor.

Hard Start Kit - Required when using TXV indoor coil. Also, provides increased starting torque for areas with low voltage.

Model	Source 1 Kit numbers
18	S1-2SA06708606
24	S1-2SA06721706
30	S1-2SA06705906
36	S1-2SA06708906
42	S1-2SA06708806
48	S1-2SA06708806
60	S1-2SA06707906

Thermostats - Compatible thermostat controls are available through accessory sourcing. For optimum performance and installation, refer to the UPGNET "Low Voltage Wiring Diagram" document to select and apply controls.

SOUND POWER RATINGS*

UNIT MODEL	(dBA)
18	75
24	76
30	76
36	76
42	76
48	77
60	78

* Rated in accordance with ARI 270-95 Standards.

TYPICAL INSTALLATION

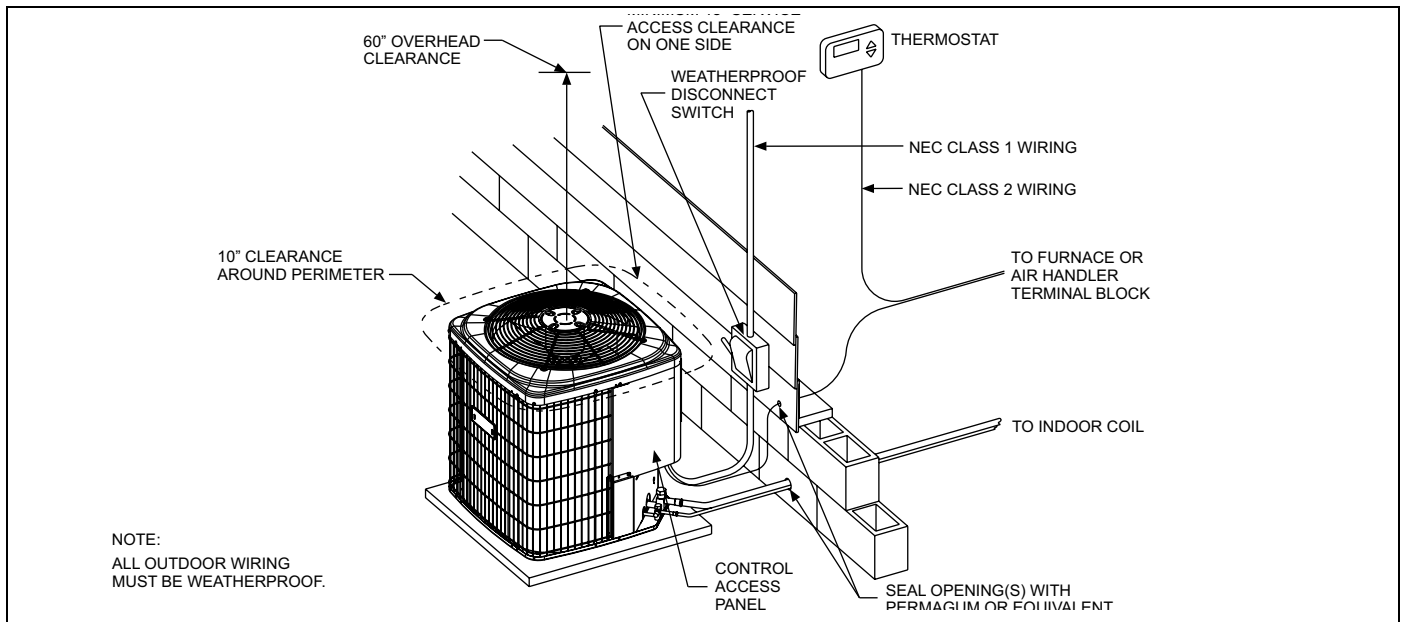

TYPICAL FIELD WIRING

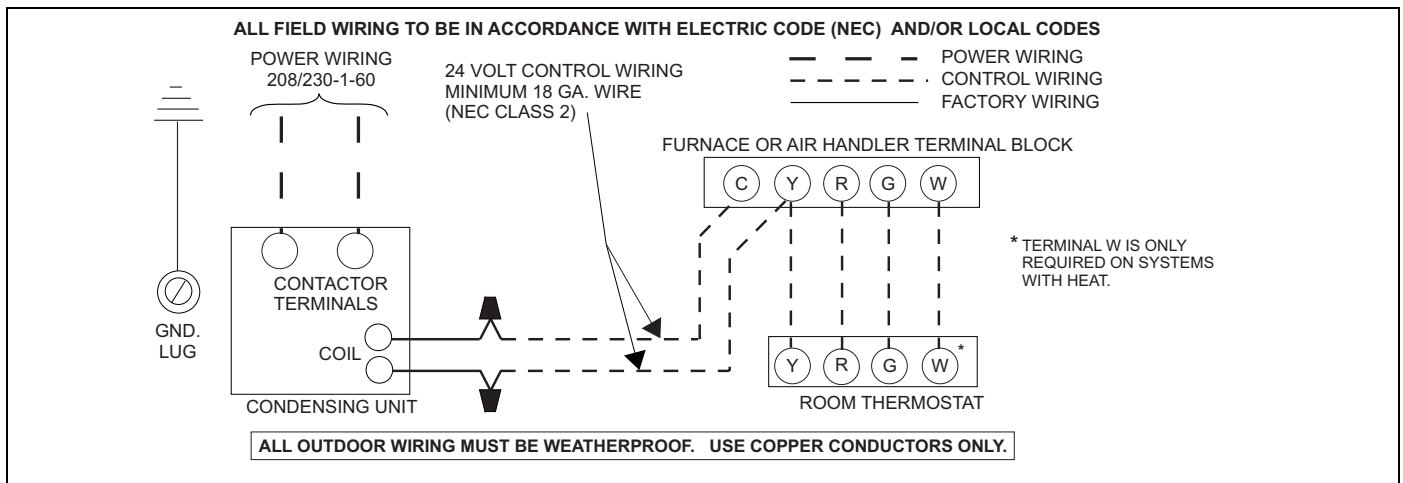

COOLING PERFORMANCE DATA																
AIR CONDITIONER MODEL NO.		GCGD18S41S3														
INDOOR COIL MODEL NO.		FC/MC/PC18														
CONDENSING ENTERING AIR TEMPERATURE	IDCFM	450					600					750				
	ID DB (°F)	80	80	75	80	80	80	80	75	80	80	80	80	75	80	80
	ID WB (°F)	57	62	62	67	72	57	62	62	67	72	57	62	62	67	72
65	T.C.	16.3	18.4	18.3	20.1	20.7	17.5	19.0	18.7	20.2	20.9	18.7	19.6	19.1	20.3	21.1
	S.C.	16.3	14.5	12.7	12.6	9.7	17.5	17.1	14.2	13.6	10.3	18.7	17.2	15.7	14.6	10.9
	KW	1.16	1.16	1.16	1.15	1.14	1.21	1.21	1.21	1.20	1.20	1.26	1.26	1.27	1.26	1.25
75	T.C.	15.6	17.4	17.3	19.0	19.9	16.8	18.1	17.7	19.3	20.1	18.1	18.8	18.2	19.5	20.3
	S.C.	15.6	14.3	12.2	12.2	9.3	16.8	16.3	13.8	13.4	10.1	18.1	18.4	15.4	14.6	10.8
	KW	1.28	1.28	1.28	1.28	1.27	1.34	1.34	1.34	1.33	1.33	1.39	1.39	1.39	1.39	1.39
85	T.C.	14.8	16.4	16.2	18.0	19.2	16.1	17.2	16.7	18.4	19.3	17.4	18.0	17.3	18.8	19.5
	S.C.	14.8	14.0	11.8	11.7	9.0	16.1	15.6	13.5	13.2	9.8	17.4	17.2	15.1	14.6	10.6
	KW	1.40	1.41	1.40	1.41	1.41	1.46	1.46	1.46	1.46	1.47	1.52	1.52	1.52	1.52	1.52
95	T.C.	14.0	15.4	15.1	17.0	18.4	15.4	16.3	15.8	17.5	18.6	16.7	17.2	16.4	18.0	18.7
	S.C.	14.0	13.8	11.3	11.3	8.6	15.4	14.8	13.1	13.0	9.6	16.7	15.9	14.9	14.6	10.5
	KW	1.53	1.53	1.53	1.53	1.54	1.59	1.59	1.59	1.59	1.60	1.65	1.65	1.65	1.65	1.66
105	T.C.	13.0	14.2	13.7	15.6	17.1	14.3	15.1	14.3	16.1	17.3	15.5	16.1	15.0	16.6	17.4
	S.C.	13.0	13.1	10.7	10.8	8.3	14.3	14.0	12.4	12.5	9.3	15.5	14.9	14.0	14.3	10.3
	KW	1.69	1.69	1.69	1.70	1.71	1.75	1.75	1.75	1.76	1.77	1.82	1.82	1.81	1.82	1.83
115	T.C.	12.1	13.0	12.3	14.3	15.9	13.2	14.0	13.0	14.7	16.0	14.3	15.0	13.6	15.2	16.2
	S.C.	12.1	12.4	10.1	10.3	8.0	13.2	13.1	11.7	12.1	9.0	14.3	13.8	13.2	13.9	10.1
	KW	1.85	1.85	1.84	1.85	1.87	1.91	1.91	1.91	1.92	1.94	1.98	1.98	1.97	1.98	2.00
125	T.C.	11.1	11.9	10.9	12.9	14.7	12.1	12.9	11.6	13.4	14.8	13.1	13.9	12.3	13.8	14.9
	S.C.	11.1	11.8	9.5	9.8	7.6	12.1	12.3	10.9	11.7	8.7	13.1	12.8	12.3	13.5	9.8
	KW	2.00	2.00	1.99	2.01	2.04	2.08	2.07	2.06	2.08	2.10	2.15	2.14	2.13	2.15	2.16

NOTE: ALL CAPACITIES INCLUDE INDOOR FAN HEAT AT 1250 BTUH/1000 CFM.

Multipliers for determining the performance with other indoor sections.

NOTE: For dry bulb temperatures different than those listed (between 73-87 °F), sensible capacity increases by 1060 BTUH per 1000 CFM per degree above the listed temperature and decreases by 1060 BTUH per 1000 CFM per degree below the listed temperature.

Air Handlers	Coils	T.C.	S.C.	KW
-	UC18	1.00	1.00	1.00
AHE18	-	1.02	1.07	0.92
AHP18	-	1.00	1.00	1.00
AHR18	-	1.02	1.07	1.02
AHX18	-	1.03	1.07	0.94
AV*24	-	1.03	1.05	0.94
MV12B	FC/MC18B	1.00	1.03	0.88
MX12B	FC/MC/PC18B	1.02	1.05	0.90
F4FP024	-	1.00	1.00	1.00
F6FP018	-	1.02	1.03	0.93

Furnaces	Coils	T.C.	S.C.	KW
T*(8,L)X*A12	FC/MC/PC18A	1.01	1.00	0.89
T*(8,L)X*B12	FC/MC/PC18B	1.03	1.04	0.91
T*9X*B12	FC/MC/PC18B	1.03	1.04	0.91
T*(8,L)X*A12	UC18A	1.03	1.04	0.94
T*(8,L)X*B12	UC18B	1.03	1.04	0.94
T*9X*B12	UC18B	1.03	1.04	0.94
(T*(8,L)C/T*8V)*A12	FC/MC/PC18A	1.00	0.98	0.88
(T*(8,L)C/T*8V)*B12	FC/MC/PC18B	1.00	0.98	0.92
(T*9C/T*9V)*B12	FC/MC/PC18B	1.00	0.99	0.88
(T*(8,L)C/T*8V)*A12	UC18A	1.00	0.98	0.92
(T*(8,L)C/T*8V)*B12	UC18B	1.00	0.97	0.92
(T*9C/T*9V)*B12	UC18B	1.00	0.98	0.88

COOLING PERFORMANCE DATA																
AIR CONDITIONER MODEL NO.		GCGD24S41S3														
INDOOR COIL MODEL NO.		FC/MC/PC36														
CONDENSING ENTERING AIR TEMPERATURE	IDCFM	600					800					1000				
	ID DB (°F)	80	80	75	80	80	80	80	75	80	80	80	80	75	80	80
	ID WB (°F)	57	62	62	67	72	57	62	62	67	72	57	62	62	67	72
65	T.C.	20.5	25.5	25.4	27.0	28.2	22.6	26.7	26.5	28.3	29.5	24.7	28.0	27.7	29.6	30.8
	S.C.	20.5	19.1	16.6	16.3	13.3	22.6	22.0	18.8	18.0	14.2	24.7	24.9	21.0	19.7	15.1
	KW	1.66	1.67	1.67	1.67	1.67	1.73	1.74	1.74	1.74	1.74	1.81	1.81	1.82	1.82	1.82
75	T.C.	19.1	23.5	23.4	25.5	27.2	21.4	25.0	24.7	26.9	28.6	23.7	26.4	26.0	28.2	29.9
	S.C.	19.1	18.5	15.7	15.8	12.8	21.4	21.1	18.0	17.6	13.8	23.7	23.8	20.4	19.4	14.9
	KW	1.79	1.80	1.80	1.81	1.82	1.87	1.87	1.88	1.89	1.90	1.95	1.95	1.95	1.97	1.98
85	T.C.	17.7	21.6	21.3	24.0	26.3	20.2	23.2	22.8	25.4	27.6	22.7	24.8	24.3	26.9	28.9
	S.C.	17.7	17.9	14.9	15.3	12.3	20.2	20.3	17.3	17.2	13.5	22.7	22.7	19.7	19.1	14.6
	KW	1.92	1.92	1.92	1.95	1.98	2.01	2.01	2.01	2.04	2.06	2.09	2.10	2.09	2.12	2.14
95	T.C.	16.3	19.6	19.3	22.5	25.3	19.0	21.5	21.0	24.0	26.7	21.7	23.3	22.6	25.5	28.0
	S.C.	16.3	17.3	14.1	14.7	11.9	19.0	19.5	16.5	16.8	13.1	21.6	21.6	19.0	18.9	14.4
	KW	2.05	2.05	2.05	2.09	2.14	2.14	2.15	2.14	2.18	2.22	2.24	2.24	2.23	2.27	2.30
105	T.C.	15.0	17.7	17.1	20.1	23.1	17.4	19.5	18.8	21.6	24.4	19.8	21.3	20.4	23.1	25.8
	S.C.	15.0	15.9	13.1	13.8	11.1	17.4	17.8	15.3	15.9	12.5	19.8	19.8	17.4	18.0	13.9
	KW	2.17	2.17	2.16	2.22	2.28	2.28	2.28	2.26	2.31	2.37	2.38	2.39	2.36	2.41	2.45
115	T.C.	13.8	15.8	15.0	17.9	20.9	15.9	17.6	16.6	19.3	22.2	18.0	19.4	18.3	20.7	23.6
	S.C.	13.8	14.6	12.1	12.9	10.4	15.9	16.3	14.0	15.0	11.8	17.9	17.9	15.8	17.1	13.3
	KW	2.29	2.29	2.27	2.34	2.41	2.41	2.41	2.38	2.44	2.51	2.53	2.53	2.49	2.54	2.60
125	T.C.	12.5	13.9	12.8	15.7	18.7	14.4	15.7	14.5	17.0	20.1	16.2	17.5	16.2	18.4	21.4
	S.C.	12.5	13.4	11.2	12.0	9.6	14.4	14.7	12.7	14.1	11.2	16.1	16.4	14.3	16.2	12.8
	KW	2.41	2.41	2.38	2.46	2.55	2.54	2.54	2.50	2.56	2.65	2.67	2.67	2.61	2.67	2.75

NOTE: ALL CAPACITIES INCLUDE INDOOR FAN HEAT AT 1250 BTUH/1000 CFM.

Multipliers for determining the performance with other indoor sections.

NOTE: For dry bulb temperatures different than those listed (between 73-87 °F), sensible capacity increases by 1060 BTUH per 1000 CFM per degree above the listed temperature and decreases by 1060 BTUH per 1000 CFM per degree below the listed tem

Air Handlers	Coils	T.C.	S.C.	KW	Furnaces	Coils	T.C.	S.C.	KW
-	FC/MC/PC32	1.00	1.00	1.00	T*(8,L)X*A12	FC/MC/PC32A	1.00	1.01	0.96
-	FC/MC/PC35	1.00	1.00	1.00	T*(8,L)X*B12	FC/MC/PC35B	1.00	1.02	0.92
-	FC/MC/PC37	1.00	1.00	1.00	T*9X*C16	FC/MC/PC35C	0.99	0.98	0.91
-	FC/MC/PC43	1.00	1.00	1.00	T*9X*C20	FC/MC/PC35C	1.00	1.02	0.92
-	UC36	1.00	1.00	1.00	T*(8,L)X*A12	FC/MC/PC36A	1.00	1.01	0.92
AHE24	-	1.02	1.04	0.93	T*(8,L)X*B12	FC/MC/PC36B	1.00	1.01	0.92
AHE30	-	1.02	1.04	0.93	T*9X*B12	FC/MC/PC36B	1.00	1.01	0.92
AHE36	-	1.05	1.11	0.92	T*9X*C16	FC/MC/PC36C	1.00	1.01	0.92
AHP30	-	1.00	1.01	1.00	T*9X*C20	FC/MC/PC36C	1.00	1.01	0.92
AHR24	-	0.99	0.99	0.99	T*(8,L)X*A12	FC/MC/PC37A	1.00	1.02	0.92
AHX30	-	1.00	1.01	0.92	T*(8,L)X*B12	FC/MC/PC43B	1.00	1.02	0.92
AHX36	-	1.00	1.01	0.92	(T*(8,L)C/T*8V)*A12	FC/MC/PC32A	1.00	1.02	0.96
AV*36	-	1.00	1.04	0.92	(T*(8,L)C/T*8V)*B12	FC/MC/PC35B	1.00	1.01	0.92
MV12B	FC/MC36B	1.00	1.04	0.92	(T*9C/T*9V)*B12	FC/MC/PC35B	1.00	1.02	0.92
MV12B	FC/MC35B	1.00	1.04	0.92	(T*(8,L)C/T*8V)*A12	FC/MC/PC36A	1.00	1.01	0.92
MV12B	FC/MC43B	1.00	1.04	0.92	(T*(8,L)C/T*8V)*B12	FC/MC/PC36B	1.00	1.02	0.92
MX12B	FC/MC35B	1.03	1.04	0.91	(T*9C/T*9V)*B12	FC/MC/PC36B	1.00	1.01	0.92
MX12B	FC/MC36B	1.01	1.01	0.91	(T*(8,L)C/T*8V)*A12	FC/MC/PC37A	1.00	1.02	0.92
MX12B	FC/MC43B	1.03	1.02	0.90	(T*(8,L)C/T*8V)*B12	FC/MC/PC43B	1.00	1.01	0.92
F4FP36	-	1.00	1.00	1.00	(T*9C/T*9V)*B12	FC/MC/PC43B	1.00	1.02	0.92
F6FP030	-	1.00	1.01	0.93	(T*(8,L)C/T*8V)*A12	UC36A	0.98	0.99	0.94
F6FP036	-	1.00	1.02	0.92	(T*(8,L)C/T*8V)*B12	UC36B	0.98	1.00	0.94
					(T*9C/T*9V)*B12	UC36B	0.98	1.00	0.94

COOLING PERFORMANCE DATA																
AIR CONDITIONER MODEL NO.		GCGD30S41S3														
INDOOR COIL MODEL NO.		FC/MC/PC32														
CONDENSING ENTERING AIR TEMPERATURE	IDCFM	800					1000					1200				
	ID DB (°F)	80	80	75	80	80	80	80	75	80	80	80	80	75	80	80
	ID WB (°F)	57	62	62	67	72	57	62	62	67	72	57	62	62	67	72
65	T.C.	30.2	33.4	32.8	35.2	36.5	31.7	33.9	33.4	35.5	36.7	33.2	34.3	34.1	35.9	36.9
	S.C.	28.9	26.3	22.1	21.6	16.3	30.3	29.5	24.0	23.0	17.4	31.8	32.6	25.9	24.4	18.5
	KW	2.18	2.20	2.20	2.21	2.23	2.27	2.28	2.29	2.42	2.32	2.37	2.36	2.38	2.63	2.41
75	T.C.	28.0	30.7	30.0	32.9	34.7	29.7	31.5	30.7	33.3	34.8	31.3	32.4	31.5	33.8	35.0
	S.C.	26.9	25.2	20.9	20.7	15.6	28.4	27.6	23.0	22.4	16.7	30.0	30.1	25.1	24.1	17.8
	KW	2.36	2.37	2.37	2.40	2.43	2.46	2.47	2.47	2.49	2.53	2.56	2.56	2.56	2.58	2.62
85	T.C.	25.9	28.0	27.2	30.6	32.8	27.7	29.2	28.0	31.2	33.0	29.5	30.5	28.8	31.7	33.1
	S.C.	24.8	24.0	19.8	19.8	15.0	26.5	25.8	22.0	21.8	16.1	28.2	27.5	24.3	23.8	17.1
	KW	2.54	2.54	2.54	2.59	2.64	2.65	2.65	2.64	2.56	2.73	2.76	2.75	2.74	2.54	2.83
95	T.C.	23.8	25.3	24.5	28.3	31.0	25.7	26.9	25.3	29.0	31.1	27.6	28.6	26.2	29.7	31.3
	S.C.	22.8	22.9	18.6	18.9	14.4	24.6	23.9	21.0	21.2	15.4	26.5	25.0	23.5	23.5	16.5
	KW	2.72	2.72	2.71	2.78	2.84	2.84	2.83	2.81	2.64	2.94	2.95	2.94	2.92	2.49	3.04
105	T.C.	21.8	23.1	21.7	25.2	27.9	23.4	24.6	22.6	25.8	28.0	25.0	26.1	23.5	26.4	28.1
	S.C.	20.9	21.1	17.4	17.7	13.4	22.4	22.2	19.3	19.3	14.5	24.0	23.3	21.3	20.8	15.7
	KW	2.91	3.02	2.88	2.96	3.04	3.03	3.08	2.99	2.90	3.14	3.15	3.14	3.10	2.84	3.24
115	T.C.	19.8	21.1	19.1	22.2	25.0	21.2	22.4	19.9	22.7	25.0	22.6	23.6	20.8	23.2	25.0
	S.C.	19.0	19.3	16.2	16.7	12.5	20.3	20.5	17.7	17.4	13.7	21.6	21.6	19.2	18.2	14.9
	KW	3.10	3.31	3.05	3.14	3.23	3.22	3.33	3.17	3.16	3.33	3.34	3.34	3.29	3.18	3.43
125	T.C.	17.8	19.0	16.4	19.2	22.0	19.0	20.1	17.3	19.6	22.0	20.1	21.2	18.2	20.0	22.0
	S.C.	17.1	17.5	15.1	15.6	11.6	18.2	18.7	16.1	15.6	12.9	19.2	20.0	17.1	15.6	14.2
	KW	3.28	3.61	3.22	3.31	3.42	3.41	3.57	3.34	3.42	3.52	3.53	3.54	3.47	3.53	3.63

NOTE: ALL CAPACITIES INCLUDE INDOOR FAN HEAT AT 1250 BTUH/1000 CFM.

Multipliers for determining the performance with other indoor sections.

NOTE: For dry bulb temperatures different than those listed (between 73-87 °F), sensible capacity increases by 1060 BTUH per 1000 CFM per degree above the listed temperature and decreases by 1060 BTUH per 1000 CFM per degree below the listed tem

Air Handlers	Coils	T.C.	S.C.	KW
-	FC/MC/PC35	1.00	1.00	1.00
-	FC/MC/PC37	1.00	1.00	1.00
-	FC/MC/PC43	1.00	1.00	1.00
AHE30	-	1.01	1.02	0.95
AHE36	-	1.04	1.05	0.94
AHP30	-	1.00	1.00	1.00
AHP36	-	1.00	1.00	1.00
AHR30	-	1.01	1.06	1.01
AHR36	-	1.03	1.05	1.03
AHX30	-	1.01	1.06	0.95
AHX36	-	1.03	1.06	0.95
AV*36	-	1.03	1.04	0.95
MV12B	FC/MC35B	1.00	1.03	0.92
MV16C	FC/MC35C	1.03	1.03	0.95
MV12B	FC/MC43B	1.00	1.03	0.92
MV16C	FC/MC43C	1.03	1.03	0.95
MX12B	FC/MC35B	1.03	1.08	0.95
MX16C	FC/MC35C	1.03	1.06	0.91
MX12B	FC/MC43B	1.05	1.10	0.94
MX16C	FC/MC43C	1.04	1.04	0.92
F4FP040	-	1.00	1.00	1.00
F6FP030	-	1.01	1.03	0.97
F6FP036	-	1.01	1.02	0.93

Furnaces	Coils	T.C.	S.C.	KW
T*(8,L)X*A12	FC/MC/PC32A	1.01	1.02	1.01
T*(8,L)X*B12	FC/MC/PC35B	1.03	1.09	0.99
T*(8,L)X*C16	FC/MC/PC35C	1.03	1.09	0.95
T*(8,L)X*C20	FC/MC/PC35C	0.99	0.98	0.91
T*9X*B12	FC/MC/PC35B	1.03	1.09	0.94
T*9X*C16	FC/MC/PC35C	1.03	1.07	0.94
T*(8,L)X*A12	FC/MC/PC37A	1.03	1.09	0.99
T*(8,L)X*B12	FC/MC/PC43B	1.03	1.09	0.95
T*(8,L)X*C16	FC/MC/PC43C	0.97	0.92	0.89
T*(8,L)X*C20	FC/MC/PC43C	1.02	1.01	0.94
T*9X*B12	FC/MC/PC43B	1.03	1.09	0.99
T*9X*C16	FC/MC/PC43C	1.03	1.09	0.95
T*9X*C20	FC/MC/PC43C	0.97	0.92	0.89
(T*(8,L)C/T*8V)*A12	FC/MC/PC32A	1.01	1.04	1.01
(T*(8,L)C/T*8V)*B12	FC/MC/PC35B	1.02	1.02	0.98
(T*9C/T*9V)*B12	FC/MC/PC35B	1.01	1.05	0.97
(T*(8,L)C/T*8V)*C16	FC/MC/PC35C	1.02	1.05	0.94
(T*(8,L)C/T*8V)*C20	FC/MC/PC35C	1.03	1.07	0.95
(T*9C/T*9V)*C16	FC/MC/PC35C	1.02	1.05	0.94
(T*9C/T*9V)*C20	FC/MC/PC35C	1.02	1.05	0.94
(T*(8,L)C/T*8V)*A12	FC/MC/PC37A	1.03	1.04	0.98
(T*(8,L)C/T*8V)*B12	FC/MC/PC43B	1.03	1.05	0.95
(T*9C/T*9V)*B12	FC/MC/PC43B	1.03	1.05	0.99
(T*(8,L)C/T*8V)*C16	FC/MC/PC43C	1.03	1.05	0.95
(T*(8,L)C/T*8V)*C20	FC/MC/PC43C	1.03	1.05	0.95
(T*9C/T*9V)*C16	FC/MC/PC43C	1.03	1.05	0.95
(T*9C/T*9V)*C20	FC/MC/PC43C	1.03	1.05	0.95

COOLING PERFORMANCE DATA																
AIR CONDITIONER MODEL NO.		GCGD36S41S3														
INDOOR COIL MODEL NO.		FC/MC/PC37														
CONDENSING ENTERING AIR TEMPERATURE	IDCFM	1000					1200					1400				
	ID DB (°F)	80	80	75	80	80	80	80	75	80	80	80	80	75	80	80
	ID WB (°F)	57	62	62	67	72	57	62	62	67	72	57	62	62	67	72
65	T.C.	35.3	37.4	37.0	39.3	40.4	36.3	38.1	37.4	39.7	40.2	37.3	38.8	37.8	40.1	40.1
	S.C.	33.1	29.8	25.3	24.2	18.1	34.1	31.8	26.8	25.2	18.5	35.2	33.8	28.3	26.1	18.9
	KW	2.40	2.42	2.41	2.44	2.44	2.49	2.50	2.50	2.53	2.53	2.58	2.58	2.60	2.61	2.63
75	T.C.	33.8	35.6	35.1	37.7	39.3	34.9	36.4	35.6	38.1	39.3	36.1	37.2	36.1	38.5	39.3
	S.C.	31.7	29.4	24.8	23.9	17.9	32.9	31.4	26.5	25.1	18.5	34.1	33.3	28.2	26.3	19.1
	KW	2.61	2.63	2.62	2.66	2.67	2.71	2.72	2.71	2.75	2.77	2.80	2.80	2.80	2.83	2.86
85	T.C.	32.4	33.8	33.3	36.2	38.1	33.6	34.7	33.8	36.6	38.3	34.8	35.6	34.4	37.0	38.4
	S.C.	30.4	29.0	24.3	23.5	17.7	31.7	30.9	26.1	25.0	18.5	33.0	32.8	28.0	26.5	19.3
	KW	2.82	2.84	2.84	2.88	2.91	2.92	2.93	2.92	2.96	3.00	3.02	3.03	3.01	3.05	3.09
95	T.C.	31.0	32.0	31.5	34.6	37.0	32.3	33.0	32.1	35.0	37.3	33.6	34.0	32.7	35.4	37.6
	S.C.	29.0	28.6	23.7	23.1	17.5	30.5	30.5	25.8	24.9	18.5	31.9	32.3	27.9	26.6	19.5
	KW	3.04	3.05	3.05	3.09	3.14	3.14	3.15	3.13	3.18	3.23	3.24	3.25	3.22	3.27	3.32
105	T.C.	28.0	28.9	27.8	31.1	34.3	28.9	29.9	28.5	31.6	34.6	29.9	30.9	29.2	32.0	34.9
	S.C.	26.3	26.2	22.0	21.9	16.6	27.4	27.8	23.8	23.8	17.7	28.5	29.4	25.6	25.7	18.9
	KW	3.25	3.25	3.23	3.30	3.37	3.36	3.36	3.33	3.39	3.47	3.47	3.47	3.43	3.49	3.56
115	T.C.	25.0	25.9	24.3	27.8	31.7	25.7	26.9	25.1	28.2	32.0	26.4	27.9	25.9	28.7	32.3
	S.C.	23.7	23.9	20.3	20.8	15.8	24.4	25.2	21.8	22.8	17.0	25.2	26.6	23.4	24.7	18.3
	KW	3.45	3.46	3.42	3.50	3.60	3.57	3.57	3.52	3.60	3.70	3.68	3.69	3.63	3.70	3.79
125	T.C.	22.1	22.9	20.7	24.4	29.0	22.5	23.9	21.7	24.9	29.3	22.9	24.9	22.6	25.4	29.6
	S.C.	21.1	21.5	18.6	19.7	15.0	21.5	22.7	19.9	21.7	16.3	21.9	23.8	21.1	23.8	17.7
	KW	3.65	3.66	3.60	3.70	3.83	3.78	3.78	3.71	3.80	3.93	3.90	3.91	3.83	3.91	4.03

NOTE: ALL CAPACITIES INCLUDE INDOOR FAN HEAT AT 1250 BTUH/1000 CFM.

Multipliers for determining the performance with other indoor sections.

NOTE: For dry bulb temperatures different than those listed (between 73-87 °F), sensible capacity increases by 1060 BTUH per 1000 CFM per degree above the listed temperature and decreases by 1060 BTUH per 1000 CFM per degree below the listed tem

Air Handlers	Coils	T.C.	S.C.	KW
-	FC/MC/PC43	1.00	1.00	1.00
-	FC/MC/PC48	1.00	1.00	1.00
-	UC48	1.00	1.00	1.00
AHE36	-	1.02	1.02	0.93
AHE42	-	1.02	1.04	0.92
AHP36	-	1.00	1.00	1.00
AHP42	-	1.00	1.00	1.00
AHR36	-	0.99	0.99	0.99
AHR42	-	1.02	1.02	0.99
AHX36	-	1.01	1.01	0.96
AHX42	-	1.01	1.02	0.94
AV*36	-	1.00	1.02	0.92
MV12B	FC/MC43B	1.01	1.02	0.95
MV16C	FC/MC43C	1.03	1.02	0.94
MV16C	FC/MC48C	1.03	1.02	0.94
MV20D	FC/MC48D	1.03	1.03	0.94
MV12D	FC/MC48D	1.00	1.02	0.92
MX12B	FC/MC43B	1.01	1.02	0.95
MX16C	FC/MC43C	1.01	1.01	0.91
MX12D	FC/MC48D	1.03	1.03	0.92
MX16C	FC/MC48C	1.03	1.03	0.91
F5FP048	-	1.00	1.00	1.00
F6FP042	-	1.02	1.04	0.98

Furnaces	Coils	T.C.	S.C.	KW
T*(8,L)X*A12	FC/MC/PC37A	1.01	1.02	0.98
T*(8,L)X*B12	FC/MC/PC43B	1.01	1.02	0.98
T*(8,L)X*C16	FC/MC/PC43C	1.01	1.00	0.96
T*(8,L)X*C20	FC/MC/PC43C	1.02	1.03	0.96
T*9X*B12	FC/MC/PC43B	1.01	1.02	0.98

Furnaces	Coils	T.C.	S.C.	KW
T*9X*C16	FC/MC/PC43C	1.01	1.02	0.98
T*9X*C20	FC/MC/PC43C	1.00	0.99	0.96
T*(8,L)X*C16	FC/MC/PC48C	1.02	1.02	0.97
T*(8,L)X*C20	FC/MC/PC48C	1.02	1.04	0.98
T*9X*C16	FC/MC/PC48C	1.02	1.04	0.98
T*9X*C20	FC/MC/PC48C	1.01	1.01	0.97
T*9X*D20	FC/MC/PC48D	1.01	1.01	0.97
T*(8,L)X*C16	UC48C	0.98	1.00	0.93
T*(8,L)X*C20	UC48C	0.99	1.02	0.95
T*9X*C16	UC48C	0.99	1.00	0.97
T*9X*C20	UC48C	0.97	0.99	0.95
T*9X*D20	UC48D	0.97	0.99	0.95
(T*(8,L)C/T*8V)*A12	FC/MC/PC37A	0.97	0.93	0.97
(T*(8,L)C/T*8V)*B12	FC/MC/PC43B	1.01	1.02	1.01
(T*9C/T*9V)*B12	FC/MC/PC43B	1.01	1.02	1.01
(T*(8,L)C/T*8V)*C16	FC/MC/PC43C	1.02	1.02	0.97
(T*(8,L)C/T*8V)*C20	FC/MC/PC43C	1.02	1.02	0.93
(T*9C/T*9V)*C16	FC/MC/PC43C	1.01	1.02	0.97
(T*9C/T*9V)*C20	FC/MC/PC43C	1.02	1.02	0.97
(T*(8,L)C/T*8V)*C16	FC/MC/PC48C	1.03	1.05	0.94
(T*(8,L)C/T*8V)*C20	FC/MC/PC48C	1.03	1.05	0.94
(T*9C/T*9V)*C16	FC/MC/PC48C	1.03	1.05	0.98
(T*9C/T*9V)*C20	FC/MC/PC48C	1.03	1.07	0.98
(T*9C/T*9V)*D20	FC/MC/PC48D	1.03	1.06	0.94
(T*(8,L)C/T*8V)*C16	UC48C	0.99	1.00	0.95
(T*(8,L)C/T*8V)*C20	UC48C	0.99	1.00	0.95
(T*9C/T*9V)*C16	UC48C	0.99	1.00	0.95
(T*9C/T*9V)*C20	UC48C	1.00	1.03	1.00
(T*9C/T*9V)*D20	UC48D	0.99	1.01	0.95

COOLING PERFORMANCE DATA																
AIR CONDITIONER MODEL NO.		GCGD42S41S3														
INDOOR COIL MODEL NO.		FC/MC/PC43														
CONDENSING ENTERING AIR TEMPERATURE	IDCFM	1200					1400					1600				
	ID DB (°F)	80	80	75	80	80	80	80	75	80	80	80	80	75	80	80
	ID WB (°F)	57	62	62	67	72	57	62	62	67	72	57	62	62	67	72
65	T.C.	43.6	44.7	42.9	46.2	47.7	45.1	45.7	44.3	47.7	49.0	46.7	46.7	45.7	49.3	50.2
	S.C.	40.8	35.0	29.2	28.2	21.1	42.2	36.9	30.9	29.7	22.5	43.6	38.7	32.6	31.2	23.8
	KW	2.89	2.90	2.90	2.91	2.96	2.97	2.98	2.98	3.00	3.04	3.04	3.06	3.06	3.09	3.12
75	T.C.	41.6	42.2	40.5	44.4	45.8	43.4	43.6	42.0	45.8	47.1	45.3	44.9	43.5	47.3	48.3
	S.C.	38.7	34.6	28.7	28.0	20.9	40.4	36.8	30.6	29.6	22.0	42.2	39.0	32.5	31.2	23.2
	KW	3.14	3.15	3.15	3.18	3.24	3.23	3.23	3.23	3.27	3.32	3.31	3.32	3.32	3.36	3.41
85	T.C.	39.6	39.6	38.2	42.6	43.9	41.7	41.4	39.7	43.9	45.2	43.9	43.2	41.2	45.2	46.4
	S.C.	36.6	34.1	28.2	27.7	20.8	38.6	36.7	30.3	29.5	21.6	40.7	39.3	32.4	31.3	22.5
	KW	3.39	3.39	3.40	3.46	3.51	3.49	3.49	3.48	3.55	3.61	3.58	3.58	3.57	3.64	3.70
95	T.C.	37.6	37.1	35.9	40.8	42.0	40.0	39.3	37.4	42.0	43.3	42.5	41.4	38.9	43.2	44.5
	S.C.	34.4	33.7	27.6	27.5	20.6	36.9	36.6	29.9	29.4	21.2	39.3	39.6	32.3	31.3	21.8
	KW	3.64	3.64	3.64	3.73	3.79	3.75	3.74	3.74	3.82	3.89	3.85	3.84	3.83	3.91	3.99
105	T.C.	34.7	34.1	32.2	36.8	38.0	36.9	36.1	33.6	37.9	39.1	39.1	38.1	35.1	39.1	40.2
	S.C.	31.8	31.6	26.1	25.9	19.2	33.9	33.9	28.3	28.0	20.1	36.1	36.3	30.5	30.0	20.9
	KW	3.89	3.89	3.88	3.97	4.08	4.01	4.00	3.97	4.07	4.18	4.12	4.11	4.07	4.17	4.28
115	T.C.	31.9	31.2	28.7	32.8	34.2	33.9	33.1	30.0	34.0	35.1	35.9	34.9	31.3	35.1	36.1
	S.C.	29.2	29.5	24.6	24.4	17.9	31.1	31.4	26.7	26.5	18.9	32.9	33.2	28.9	28.6	20.0
	KW	4.14	4.14	4.10	4.21	4.36	4.26	4.25	4.20	4.32	4.46	4.38	4.37	4.30	4.42	4.56
125	T.C.	29.1	28.3	25.1	28.9	30.4	30.9	30.0	26.3	30.0	31.1	32.6	31.7	27.5	31.2	31.9
	S.C.	26.7	27.5	23.1	23.0	16.5	28.2	28.8	25.1	25.1	17.8	29.7	30.1	27.2	27.3	19.1
	KW	4.39	4.38	4.33	4.45	4.64	4.51	4.51	4.43	4.56	4.74	4.64	4.63	4.53	4.67	4.85

NOTE: ALL CAPACITIES INCLUDE INDOOR FAN HEAT AT 1250 BTUH/1000 CFM.

Multipliers for determining the performance with other indoor sections.

NOTE: For dry bulb temperatures different than those listed (between 73-87 °F), sensible capacity increases by 1060 BTUH per 1000 CFM per degree above the listed temperature and decreases by 1060 BTUH per 1000 CFM per degree below the listed tem

Air Handlers	Coils	T.C.	S.C.	KW
-	FC/MC/PC48	1.00	1.00	1.00
-	UC48	1.00	1.00	1.00
AHE42	-	1.02	1.04	0.94
AHP42	-	0.98	1.00	0.98
AHR42	-	1.01	1.05	1.01
AHX42	-	1.00	1.02	0.92
AV*48	-	1.00	1.02	0.92
AV*60	-	1.00	1.02	0.92
MV16C	FC/MC43C	1.00	1.03	0.92
MV16C	FC/MC48C	1.00	1.03	0.92
MV20D	FC/MC48D	1.00	1.03	0.92
MX16C	FC/MC43C	1.01	1.03	0.93
MX16C	FC/MC48C	1.02	1.04	0.92
MX20D	FC/MC48D	1.02	1.03	0.94
F5FP048	-	0.98	1.00	0.98
F6FP042	-	1.00	1.03	0.94
F6FP048	-	0.99	1.01	0.93

Furnaces	Coils	T.C.	S.C.	KW
T*(8,L)X*B12	FC/MC/PC43B	1.00	0.99	0.96
T*(8,L)X*C16	FC/MC/PC43C	1.00	1.02	0.96
T*(8,L)X*C20	FC/MC/PC43C	1.00	1.01	0.96
T*9X*B12	FC/MC/PC43B	1.00	0.99	0.96
T*9X*C16	FC/MC/PC43C	1.00	1.01	1.00
T*9X*C20	FC/MC/PC43C	1.00	1.01	1.00

Furnaces	Coils	T.C.	S.C.	KW
T*(8,L)X*C16	FC/MC/PC48C	1.00	1.01	0.96
T*(8,L)X*C20	FC/MC/PC48C	1.00	1.03	0.96
T*9X*C16	FC/MC/PC48C	1.00	1.00	0.96
T*9X*C20	FC/MC/PC48C	1.00	1.00	0.96
T*9X*D20	FC/MC/PC48D	1.00	1.02	0.96
T*(8,L)X*C16	UC48C	1.00	1.01	1.00
T*(8,L)X*C20	UC48C	1.00	1.03	1.00
T*9X*C16	UC48C	0.99	1.00	0.99
T*9X*C20	UC48C	1.00	1.01	1.00
T*9X*D20	UC48D	1.00	1.01	1.00
(T*(8,L)C/T*8V)*C16	FC/MC/PC43C	1.00	1.03	0.96
(T*(8,L)C/T*8V)*C20	FC/MC/PC43C	1.00	1.04	0.96
(T*9C/T*9V)*C16	FC/MC/PC43C	1.00	1.01	1.00
(T*9C/T*9V)*C20	FC/MC/PC43C	1.00	1.01	1.00
(T*(8,L)C/T*8V)*C16	FC/MC/PC48C	1.00	1.03	0.96
(T*(8,L)C/T*8V)*C20	FC/MC/PC48C	1.00	1.03	0.96
(T*9C/T*9V)*C16	FC/MC/PC48C	1.00	1.04	0.96
(T*9C/T*9V)*C20	FC/MC/PC48C	1.00	1.04	0.96
(T*9C/T*9V)*D20	FC/MC/PC48D	1.00	1.02	0.96
(T*(8,L)C/T*8V)*C16	UC48C	0.99	1.03	0.99
(T*(8,L)C/T*8V)*C20	UC48C	0.99	1.03	0.95
(T*9C/T*9V)*C16	UC48C	0.99	1.03	0.99
(T*9C/T*9V)*C20	UC48C	0.99	1.03	0.99
(T*9C/T*9V)*D20	UC48D	0.99	1.03	0.99

COOLING PERFORMANCE DATA																
AIR CONDITIONER MODEL NO.		GCGD48S41S3														
INDOOR COIL MODEL NO.		FC/MC/PC48														
CONDENSING ENTERING AIR TEMPERATURE	IDCFM	1400					1600					1800				
	ID DB (°F)	80	80	75	80	80	80	80	75	80	80	80	80	75	80	80
	ID WB (°F)	57	62	62	67	72	57	62	62	67	72	57	62	62	67	72
65	T.C.	49.7	51.4	50.5	55.8	54.6	52.0	53.1	51.9	56.3	55.4	54.4	54.7	53.2	56.9	56.3
	S.C.	46.9	42.8	35.7	35.7	25.9	48.8	45.6	37.9	37.1	27.3	50.8	48.3	40.1	38.5	28.8
	KW	3.36	3.41	3.42	3.45	3.50	3.38	3.42	3.43	3.46	3.52	3.41	3.43	3.45	3.47	3.53
75	T.C.	47.5	48.6	47.7	52.8	52.3	49.8	50.3	48.9	53.6	53.1	52.0	52.1	50.1	54.3	53.8
	S.C.	44.6	41.7	34.7	34.6	25.2	46.6	44.5	36.9	36.3	26.6	48.6	47.2	39.0	37.9	27.9
	KW	3.65	3.68	3.68	3.74	3.82	3.67	3.70	3.70	3.76	3.83	3.70	3.72	3.72	3.77	3.85
85	T.C.	45.4	45.8	44.8	49.9	50.1	47.5	47.6	46.0	50.8	50.7	49.7	49.4	47.1	51.7	51.3
	S.C.	42.3	40.6	33.7	33.5	24.6	44.4	43.4	35.8	35.4	25.8	46.4	46.1	37.9	37.3	27.0
	KW	3.93	3.95	3.95	4.04	4.14	3.97	3.98	3.97	4.06	4.15	4.00	4.01	3.99	4.08	4.17
95	T.C.	43.2	42.9	42.0	46.9	47.9	45.3	44.8	43.0	48.0	48.4	47.3	46.7	44.1	49.1	48.9
	S.C.	40.1	39.6	32.7	32.4	23.9	42.1	42.3	34.8	34.6	25.0	44.2	45.0	36.9	36.7	26.1
	KW	4.22	4.22	4.22	4.34	4.46	4.26	4.26	4.24	4.36	4.47	4.30	4.30	4.27	4.39	4.49
105	T.C.	39.8	39.3	37.3	42.4	43.5	41.6	41.1	38.4	43.4	44.0	43.4	42.8	39.5	44.3	44.5
	S.C.	36.8	36.7	30.7	30.7	22.7	38.6	39.0	32.7	32.8	23.7	40.5	41.2	34.7	34.9	24.8
	KW	4.52	4.52	4.49	4.62	4.77	4.57	4.57	4.52	4.65	4.79	4.61	4.61	4.55	4.67	4.81
115	T.C.	36.4	35.9	32.7	37.9	39.3	38.0	37.5	33.9	38.9	39.7	39.6	39.0	35.1	39.8	40.2
	S.C.	33.6	34.0	28.7	29.0	21.5	35.2	35.7	30.6	31.1	22.5	36.9	37.4	32.5	33.1	23.6
	KW	4.82	4.82	4.76	4.89	5.07	4.87	4.86	4.79	4.92	5.10	4.92	4.91	4.82	4.95	5.13
125	T.C.	33.1	32.4	28.1	33.5	35.0	34.5	33.8	29.4	34.4	35.5	35.9	35.3	30.6	35.2	35.9
	S.C.	30.4	31.2	26.7	27.3	20.3	31.9	32.5	28.5	29.3	21.3	33.3	33.7	30.4	31.3	22.3
	KW	5.11	5.11	5.02	5.17	5.38	5.17	5.16	5.06	5.20	5.41	5.22	5.21	5.09	5.23	5.44

NOTE: ALL CAPACITIES INCLUDE INDOOR FAN HEAT AT 1250 BTUH/1000 CFM.

Multipliers for determining the performance with other indoor sections.

NOTE: For dry bulb temperatures different than those listed (between 73-87 °F), sensible capacity increases by 1060 BTUH per 1000 CFM per degree above the listed temperature and decreases by 1060 BTUH per 1000 CFM per degree below the listed tem

Air Handlers	Coils	T.C.	S.C.	KW
-	FC/MC/PC60	1.00	1.00	1.00
-	UC48	1.00	1.00	1.00
-	UC60	1.00	1.00	1.00
AHE48	-	0.98	1.01	0.94
AHP48	-	1.00	1.00	1.00
AHP60	-	1.00	1.02	1.00
AHR48	-	1.00	1.01	1.00
AHX48	-	1.00	1.03	0.96
AV*48	-	1.00	1.02	0.92
AV*60	-	1.00	1.02	0.92
MV16C	FC/MC48C	1.00	1.02	0.92
MV20D	FC/MC48D	1.00	1.02	0.92
MV16C	FC/PC60C	0.99	1.00	0.95
MV20D	FC/MC60D	1.00	1.02	0.92
MX16C	FC/MC48C	1.01	1.03	0.97
MX20D	FC/MC48D	1.00	0.99	0.94
MX16C	FC/PC60C	1.01	1.01	0.95
MX20D	FC/MC60D	1.01	1.01	0.93
F5FP048	-	1.00	1.00	1.00
F5FP060	-	1.00	1.00	1.00
F6FP048	-	0.98	1.01	0.95
F4FV060	-	1.00	1.01	0.96

Furnaces	Coils	T.C.	S.C.	KW
T*(8,L)X*C16	FC/MC/PC48C	1.00	1.00	1.00
T*(8,L)X*C20	FC/MC/PC48C	1.00	1.00	1.00
T*9X*C16	FC/MC/PC48C	1.00	1.01	1.00
T*9X*C20	FC/MC/PC48C	1.00	1.00	1.00
T*9X*D20	FC/MC/PC48D	1.00	1.01	1.00
T*(8,L)X*C16	FC/PC60C	1.00	1.01	1.00
T*(8,L)X*C20	FC/MC/PC60D	1.00	1.01	1.00
T*9X*C16	FC/PC60C	0.98	1.01	0.98
T*9X*C20	FC/PC60C	0.98	1.01	0.98
T*9X*D20	FC/MC/PC60D	0.99	0.98	0.99
(T*(8,L)C/T*8V)*C16	FC/MC/PC48C	1.00	1.02	1.00
(T*(8,L)C/T*8V)*C20	FC/MC/PC48C	1.00	1.02	1.00
(T*9C/T*9V)*C16	FC/MC/PC48C	1.00	1.01	1.00
(T*9C/T*9V)*C20	FC/MC/PC48C	1.00	1.01	1.00
(T*9C/T*9V)*D20	FC/MC/PC48D	1.00	1.02	1.00
(T*9C/T*9V)*D20	FC/MC/PC60D	1.00	1.02	1.00
(T*(8,L)C/T*8V)*C16	FC/PC60C	1.00	1.02	1.00
(T*(8,L)C/T*8V)*C20	FC/PC60C	1.00	1.02	0.96
(T*9C/T*9V)*C16	FC/PC60C	1.00	1.02	1.00
(T*9C/T*9V)*C20	FC/PC60C	1.00	1.02	1.00

COOLING PERFORMANCE DATA

AIR CONDITIONER MODEL NO.		GCGD60S41S3														
INDOOR COIL MODEL NO.		FC/MC/PC60														
CONDENSING ENTERING AIR TEMPERATURE	IDCFM	1600					1800					2000				
	ID DB (°F)	80	80	75	80	80	80	80	75	80	80	80	80	75	80	80
	ID WB (°F)	57	62	62	67	72	57	62	62	67	72	57	62	62	67	72
65	T.C.	55.5	61.1	59.4	62.4	64.9	57.7	62.9	60.1	63.8	66.9	59.9	64.7	60.8	65.3	68.8
	S.C.	54.5	49.8	40.0	39.7	28.6	56.4	52.4	42.4	41.2	30.8	58.3	54.9	44.9	42.7	32.9
	KW	3.68	3.73	3.74	3.76	3.80	3.77	3.81	3.81	3.85	3.88	3.86	3.90	3.89	3.94	3.95
75	T.C.	54.5	58.5	56.4	60.1	63.1	56.6	60.3	57.4	61.6	65.0	58.8	62.2	58.4	63.1	66.8
	S.C.	52.1	48.7	39.2	38.7	28.5	53.9	51.3	41.6	40.4	30.4	55.8	53.9	44.1	42.1	32.4
	KW	4.14	4.17	4.17	4.21	4.26	4.23	4.25	4.25	4.29	4.34	4.31	4.34	4.33	4.38	4.42
85	T.C.	53.4	55.9	53.3	57.7	61.4	55.5	57.8	54.7	59.3	63.1	57.7	59.7	56.0	60.8	64.8
	S.C.	49.7	47.6	38.3	37.7	28.4	51.5	50.2	40.8	39.6	30.1	53.2	52.8	43.2	41.5	31.8
	KW	4.59	4.61	4.60	4.66	4.71	4.68	4.69	4.69	4.74	4.80	4.77	4.77	4.77	4.82	4.89
95	T.C.	52.4	53.4	50.3	55.4	59.6	54.4	55.3	51.9	57.0	61.2	56.5	57.2	53.6	58.6	62.7
	S.C.	47.3	46.5	37.5	36.7	28.4	49.0	49.1	40.0	38.8	29.8	50.6	51.8	42.4	40.9	31.2
	KW	5.05	5.05	5.03	5.10	5.17	5.13	5.13	5.12	5.18	5.26	5.22	5.21	5.21	5.26	5.35
105	T.C.	49.4	50.0	46.7	51.7	55.4	51.7	52.0	48.3	53.3	57.2	54.0	53.9	50.0	54.9	58.9
	S.C.	44.6	44.4	36.2	35.2	26.9	46.3	46.6	38.6	37.4	28.4	48.0	48.9	41.0	39.5	29.8
	KW	5.64	5.63	5.61	5.70	5.78	5.73	5.72	5.70	5.78	5.87	5.83	5.81	5.80	5.86	5.97
115	T.C.	46.6	46.7	43.3	48.1	51.4	49.1	48.7	44.8	49.7	53.3	51.5	50.8	46.4	51.3	55.2
	S.C.	42.0	42.3	34.9	33.8	25.4	43.7	44.2	37.3	36.1	27.0	45.5	46.1	39.7	38.3	28.5
	KW	6.21	6.20	6.17	6.29	6.37	6.32	6.30	6.27	6.37	6.47	6.42	6.40	6.36	6.45	6.57
125	T.C.	43.7	43.5	39.8	44.5	47.3	46.4	45.5	41.3	46.1	49.4	49.1	47.6	42.9	47.7	51.5
	S.C.	39.3	40.3	33.7	32.5	24.0	41.1	41.8	36.0	34.7	25.6	43.0	43.2	38.3	37.0	27.2
	KW	6.79	6.77	6.73	6.87	6.96	6.90	6.88	6.83	6.95	7.06	7.01	6.98	6.93	7.03	7.16

NOTE: ALL CAPACITIES INCLUDE INDOOR FAN HEAT AT 1250 BTUH/1000 CFM.

Multipliers for determining the performance with other indoor sections.

NOTE: For dry bulb temperatures different than those listed (between 73-87 °F), sensible capacity increases by 1060 BTUH per 1000 CFM per degree above the listed temperature and decreases by 1060 BTUH per 1000 CFM per degree below the listed tem

Air Handlers	Coils	T.C.	S.C.	KW
-	FC/MC62	1.00	1.00	1.00
-	FC64	1.00	1.01	0.98
-	UC60	1.00	1.00	1.00
AHE60	-	1.03	1.03	0.98
AHP60	-	1.00	1.00	1.00
AHR60	-	1.00	1.00	1.00
AHX60	-	1.03	1.04	0.98
AV*60	-	1.02	1.01	1.02
MV20D	FC/MC60D	1.00	1.00	1.00
MV20D	FC/MC62D	1.00	1.00	1.00
MV20D	FC64D	1.00	1.01	0.96
MX20D	FC/MC60D	1.01	1.01	0.96
MX20D	FC/MC62D	1.02	1.01	0.95
MX20D	FC64D	1.03	1.03	0.94
F5FP060	-	1.00	1.00	1.00
F6FP060	-	1.01	1.01	0.96
F4FV060	-	1.00	1.00	1.00

Furnaces	Coils	T.C.	S.C.	KW
T*(8,L)X*C16	FC/PC60C	0.99	0.98	0.99
T*(8,L)X*C20	FC/MC/PC60D	1.00	0.98	1.00
T*9X*C16	FC/PC60C	0.99	0.98	0.99
T*9X*C20	FC/PC60C	0.99	0.98	0.99
T*9X*D20	FC/MC/PC60D	1.00	0.98	1.00
T*9X*C20	FC/MC/PC60D	0.98	0.97	0.98
T*(8,L)X*C20	FC/MC62D	0.99	1.00	0.99
T*(8,L)X*C16	UC60C	0.98	0.97	0.98
T*(8,L)X*C20	UC60D	0.98	0.97	0.98
T*9X*D20	UC60D	0.98	0.97	0.98
T*(8,L)X*C20	UC60D	0.99	1.00	0.99
T*9X*C20	UC60D	0.98	0.97	0.98
(T*9C/T*9V)*D20	FC/MC/PC60D	0.97	0.96	0.97
(T*(8,L)C/T*8V)*C20	FC/MC62D	0.99	0.97	0.99
(T*9C/T*9V)*C20	FC/MC62D	0.98	0.97	0.98
(T*9C/T*9V)*D20	FC/MC62D	0.98	0.97	0.98
(T*(8,L)C/T*8V)*C20	FC/PC60C	0.97	0.96	0.97
(T*9C/T*9V)*C20	FC/PC60C	0.96	0.96	0.96
(T*(8,L)C/T*8V)*C20	UC60C	0.95	0.91	0.95
(T*9C/T*9V)*C20	UC60C	0.94	0.91	0.96
(T*9C/T*9V)*D20	UC60D	0.94	0.91	0.95