

INSTALLATION INSTRUCTIONS

GAS-FIRED FURNACES DELUXE HIGH-EFFICIENCY DOWNFLOW CONDENSING MODELS

Supersedes: 650.65-N3W (991)

650.65-N3W (492)

035-09222

MODELS: PAND, (STYLE A) 60 THRU 120 MBH INPUT

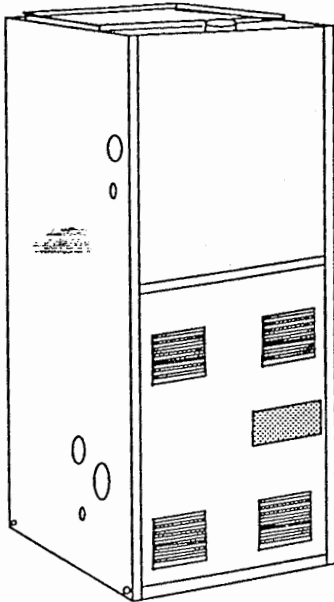

DOWNFLOW MODELS
TYPE FSP
DIRECT VENT FURNACE

FOR YOUR SAFETY

WHAT TO DO IF YOU SMELL GAS

- Do not try to light any appliance.
- Open windows.
- Do not touch any electrical switch; do not use any phone in your building.
- Extinguish any open flames.
- Immediately call your gas supplier from a neighbor's phone. Follow the gas supplier's instructions.
- If you cannot reach your gas supplier, call the fire department.

FOR YOUR SAFETY

Do not store or use gasoline or other flammable vapors and liquids in the vicinity of this or any other appliance.

WARNING: Improper installation, adjustment, alteration, service or maintenance can cause injury or property damage. Refer to this manual. For assistance or additional information, consult a qualified installer, service agency or the gas supplier.

CAUTION

THIS PRODUCT MUST BE INSTALLED IN STRICT COMPLIANCE WITH THE ENCLOSED INSTALLATION INSTRUCTIONS AND ANY APPLICABLE LOCAL, STATE, AND NATIONAL CODES INCLUDING, BUT NOT LIMITED TO, BUILDING, ELECTRICAL, AND MECHANICAL CODES.

WARNING

IMPROPER INSTALLATION MAY CREATE A CONDITION WHERE THE OPERATION OF THE PRODUCT COULD CAUSE PERSONAL INJURY OR PROPERTY DAMAGE.

TABLE OF CONTENTS

GENERAL INFORMATION

Description	2
Inspection	2
Notes, Cautions, & Warnings	2
Limitations & Location	3 & 5

SPECIFIC UNIT INFORMATION

Clearances	3
Nomenclature	3
Dimensions	4
Ratings & Physical Data	4
Combustion Air & Vent System	5
Unit Wiring Diagram	14

UNIT INSTALLATION

Ductwork	5 - 6
Filters	6
Combustion Air/Vent Sizing	6
Combustion Air Intake	6
Vent Pipe Connections	7
Piping Assembly	6
Vent Terminal Assembly	7
Gas Piping	8

Condensate Piping	8
Electrical Data	9
Electrical Connections	9
Safety Controls	9 - 10
Start-Up & Adjustments	10
Ignition System Checkout/Adjustment	10
Adjustment of Manifold Gas Pressure	11
Checking Gas Input	11
Adjustment of Temperature Rise	11
Adjustment of Fan Off Setting	10
Electronic Air Cleaner Connection	10
Humidifier Connection	10

OPERATION & MAINTENANCE

Sequence of Operation	11
50A50 Ignition Control	12
Maintenance	12
Air Filters	12
Blowers	13
Burners	12
Lubrication	12
Primary Heat Exchanger	12
Secondary Heat Exchanger	12 - 13
Troubleshooting	15

GENERAL INFORMATION

DESCRIPTION

This Category M, sealed combustion furnace is designed for residential installation, provided space temperature is 32°F or higher.

Model PAND units may be converted to propane (LP) gas if factory supplied components are used. Conversions required in order for the appliance to satisfactorily meet the application must be made by a CES distributor, conversion station or other qualified agency, using factory specified and/or approved parts.

INSPECTION

As soon as a unit is received, it should be inspected for possible damage during transit. If damage is evident, the extent of the damage should be noted on the carrier's freight bill. A separate request for inspection by the carrier's agent should be made in writing. Also, before installation the unit should be checked for screws or bolts which may have loosened in transit.

NOTES, CAUTIONS, & WARNINGS

The installer should pay particular attention to the words:

NOTE, CAUTION and **WARNING.** **NOTES** are intended to clarify or make the installation easier. **CAUTIONS** are given to prevent equipment damage. **WARNINGS** are given to alert the installer that personal injury and/or equipment or property damage may occur if installation procedures are not handled properly.

CAUTION: *The cooling coil must be installed in the supply air duct, downstream of the furnace.*

The furnace room must not be used as a broom closet or for any other storage purposes as a fire hazard may be created. Never store items such as the following on, near, or in contact with the furnace.

1. Spray or aerosol cans, rags, brooms, dust mops, vacuum cleaners or other cleaning tools.
2. Soap powders, bleaches, waxes or other cleaning compounds; plastic items or containers; gasoline, kerosene, cigarette lighter fluid; dry-cleaning fluids or other volatile fluid.
3. Paint thinners and other painting compounds.
4. Paper bags or other paper products.

WARNING: *Never operate the furnace with the blower door removed. To do so could result in serious personal injury and/or equipment damage.*

WARNING: *This furnace may not be common vented with any other appliance since it requires separate, properly-sized air intake and vent lines. The furnace shall not be connected to any type of B, BW or L vent or vent connector, and not connected to any portion of a factory-built or masonry chimney.*

If this furnace is replacing a common-vented furnace, it may be necessary to resize the existing vent line and chimney to prevent oversizing problems for the new combination of units. Refer to the National Gas Code (ANSI Z223.1-) or CANI-B149.1 or .2 Installation Code (latest editions).

The following steps shall be followed with each appliance remaining connected to the common venting system placed in operation, while the other appliances remaining connected to the common venting system are not in operation:

1. Seal any unused openings in the common venting system.
2. Visually inspect venting system for proper size and horizontal pitch and determine there is no blockage or restriction, leakage, corrosion or other deficiencies which could cause an unsafe condition.

3. Insofar as is practical, close all building doors and windows and all doors between the space in which the appliances remaining connected to the common venting system are located and other spaces of the building. Turn on clothes dryers and any appliance not connected to the common venting system. Turn on any exhaust fans, such as range hoods and bathroom exhausts, so they will operate at maximum speed. Do not operate a summer exhaust fan. Close fireplace dampers.
4. Follow the lighting instructions. Place the appliance being inspected in operation. Adjust the thermostat so the appliance will operate continuously.
5. Check for spillage at the draft hood relief opening after 5 minutes of main burner operation. Use the flame of a match or candle.
6. After it has been determined that each appliance remaining connected to the common venting system properly vents when tested as outlined above, return doors, windows, exhaust fans, fireplace dampers and any other gas burning appliance to their previous conditions of use.
7. If improper venting is observed during any of the previous tests, the common venting system must be corrected.
8. Any corrections to the common venting system must be in accordance with the National Fuel Gas Code Z223.1 or CAN1-B149.1 or .2 Installation Code (latest editions). If the common vent system must be resized, it should be resized to approach the minimum size as determined using the appropriate tables in Appendix G of the above codes.

CAUTION: Do not install the furnace in an unconditioned space or garage that could experience ambient temperatures of 32°F (0°C) or lower.

CAUTION: This unit must be installed in a level (1/4") position side-to-side and front-to-back to provide proper condensate drainage.

CAUTION: Do not allow return air temperature to be below 55°F for extended periods. To do so may cause condensate to occur in the main fired heat exchanger.

WARNING: Furnaces shall not be installed directly on carpeting, tile, wood or other combustible material. An accessory combustible floor base is available to allow installation on combustible flooring and must be used.

The size of the unit should be based on an acceptable heat loss calculation for the structure.

Check the rating plate to make certain the unit is equipped for the type of gas supplied, and proper electrical characteristics are available.

For installations in U.S. above 2,000 feet, reduce input 4% for each 1,000 feet above sea level.

Do not install this unit in a mobile home.

A furnace installed in a residential garage shall be located so that all burners and burner ignition devices are located not less than 18" above the garage floor, and located or protected to prevent damage by vehicles.

Allow clearances from combustible materials as listed under "Clearances to Combustibles", ensuring that service access is allowed for both the burners and blower.

LIMITATIONS & LOCATION

This furnace should be installed in accordance with all national and local building/safety codes and requirements, or in the absence of local codes, with the National Fuel Gas Code ANSI Z223.1 or CAN1-B149.1 or .2 Installation Code (latest editions), local plumbing or waste water codes, and other applicable codes.

SPECIFIC UNIT INFORMATION

CLEARANCES TO COMBUSTIBLES

Minimum clearances from combustible construction are in inches:

Top	1
Front	3
Vent Piping	0
Rear	0
Sides	0

CLEARANCES FOR ACCESS

Ample clearances should be provided to permit easy access to the unit. The following minimum clearances are recommended:

1. Twenty-four (24) inches between the front of the furnace and an adjacent wall or another appliance, when access is required for servicing and cleaning.
2. Eighteen (18) inches at the side where access is required for passage to the front when servicing or for inspection or replacement of flue/vent connections.

NOTE: In all cases, accessibility clearances shall take precedence over clearances for combustible materials where accessibility clearances are greater.

NOMENCLATURE

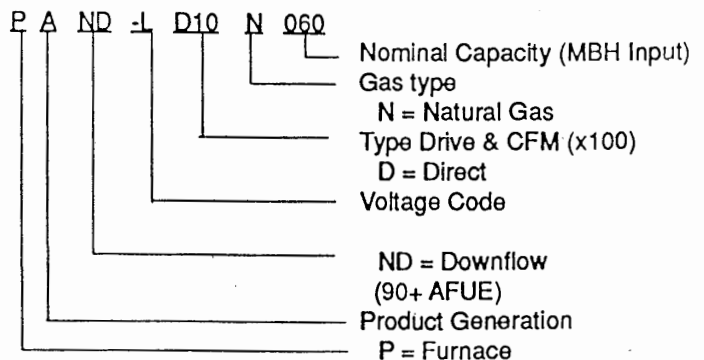

DIMENSIONS

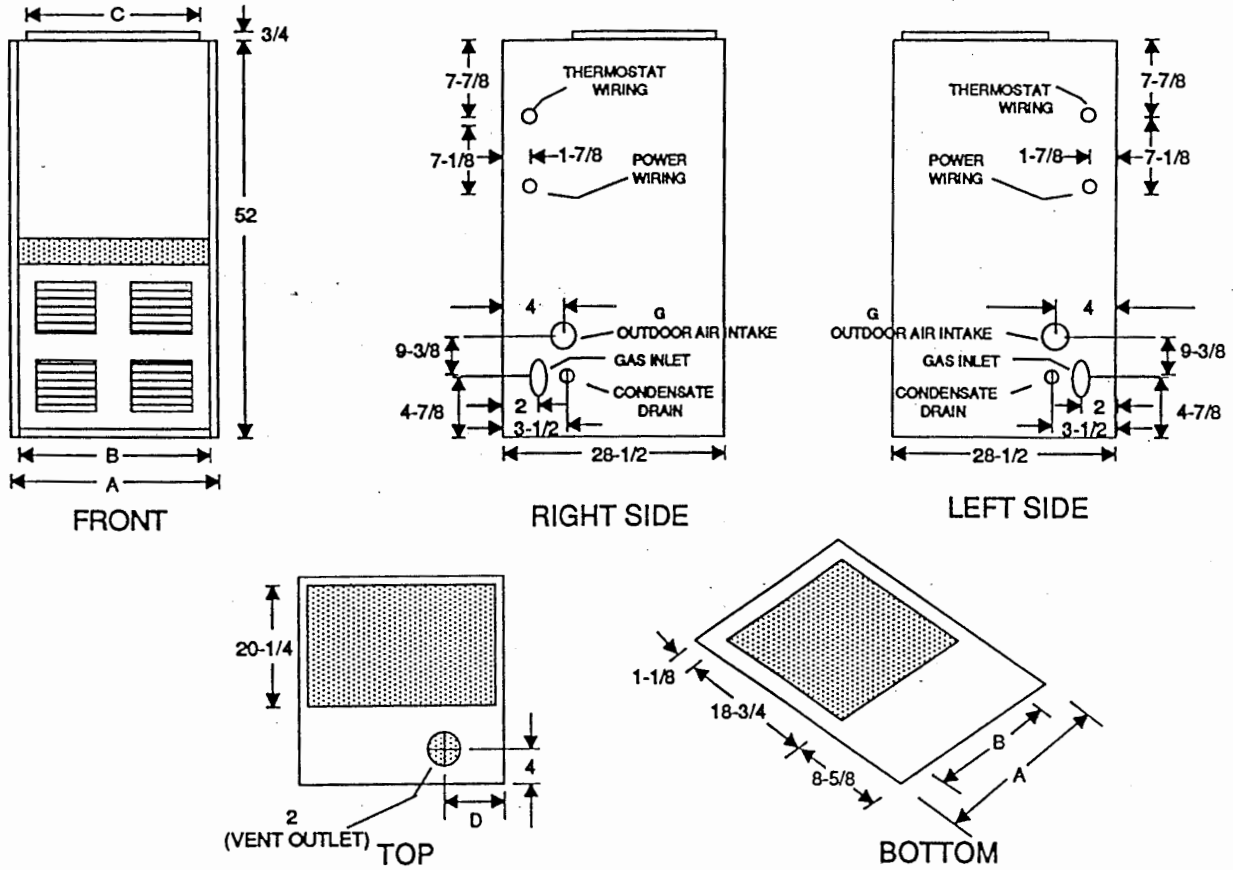

MODEL	A	B	C	D
PAND-LD10N060	16-1/4	14	15	5-3/8
PAND-LD12N080	16-1/4	14	15	5-3/8
PAND-LD16N100	22-1/4	20	21	8-3/8
PAND-LD20N120	26-1/4	24	25	10-3/8

All dimensions are in inches, and are approximate. Certified dimensions are available upon request.

TABLE 1 - RATINGS & PHYSICAL DATA

Model	Air Temp. Rise °F	Max. Outlet Temp. °F	Blower		Filter Size	Unit Amps	Max. Over-Current Protect.	Min. Wire Size (AWG) @ 75 ft. One Way
			HP	Size	Supplied (2)			
PAND-LD10N060	45-75	175	1/2	10-6	14 x 20	15	20	14
PAND-LD12N080	45-75	175	1/2	10-8	14 x 20	15	20	14
PAND-LD16N100	45-75	175	1	10-10	14 x 20	17	20	12
PAND-LD20N120	45-75	175	1	11-10	14 x 20	17	20	12

NOTES: 1. All furnaces are factory wired for 115-1-60 operation.
 2. All Filters supplied with the furnace are high-velocity, cleanable type.

When the furnace is used in conjunction with a cooling coil, the furnace must be installed parallel with or on the upstream side of the cooling unit to avoid condensation in the primary heat exchanger. When a parallel flow arrangement is used, the dampers or other means used to control air flow shall be adequate to prevent chilled air from entering the furnace, and if manually operated, must be equipped with means to prevent operation of either unit unless the damper is in the full heat or cool position.

The furnace shall be located:

1. Where a minimum amount of air intake/vent piping and elbows will be required.
2. As centralized with the air distribution as possible.
3. In an area where ventilation facilities provide for safe limits of ambient temperature under normal operating conditions. Ambient temperatures must not fall below 32°F (0° C).
4. Where it will not interfere with proper air circulation in the confined space.
5. Where the outdoor combustion air/vent terminal will not be blocked or restricted.
6. Where it will not interfere with the cleaning, servicing or removal of other appliances.

COMBUSTION AIR AND VENT SYSTEM

This furnace requires outdoor combustion air. Two separate, properly-sized pipes must be used; one bringing outdoor air from the accessory terminal kit outdoors to the furnace combustion air intake, and one from the furnace vent connection back to the terminal kit located outdoors.

The vent terminal kit should be located either through the wall (horizontal or side vent) or through the roof (vertical vent). Care should be taken to locate side vented systems where trees or shrubs will not block or restrict supply air from entering or combustion products from leaving the terminal. Also, the terminal assembly should be located as far as possible from a swimming pool or a location where swimming pool chemicals might be stored. Care must be taken such that the terminal assembly outdoors follows the clearances listed in the following table:

LOCATION CLEARANCE

Dryer Vent	4 feet
Plumbing Vent Stack	3 feet
Gas Appliance Vent Terminal	1 foot
From any opening where vent gas could enter the building	1 foot
Above grade and anticipated snow depth	1 foot
Above grade when adjacent to a public walkway	7 feet
From electric, gas meters, regulators and relief equipment - min. horizontal distance	4 feet

NOTE: Consideration must be given for degradation of building materials by flue gases.

For proper vent/combustion air intake sizing and installation, see the section of this instruction "Combustion Air/Vent Pipe Sizing."

UNIT INSTALLATION

DUCTWORK

The duct system's design and installation must:

1. Handle an air volume appropriate for the served space and within the operating parameters of the furnace specifications.
2. Be installed in accordance with standards of NFPA (National Fire Protection Association) as outlined in NFPA pamphlets 90A and 90B or applicable national, provincial, local fire and safety codes.
3. Create a closed duct system. The supply duct system must be connected to the furnace outlet and the return duct system must be connected to the furnace inlet. Both supply and return duct systems must terminate outside the space containing the furnace.
4. Generally complete a path for heated or cooled air to circulate through the heating and air conditioning equipment and to and from the conditioned space.

NOTE: The supply air temperature differential between the side discharge versus front to back discharge is substantial. It is recommended that whenever possible position the furnace so left and right side supply air is dominant.

After the unit is in the desired position, fasten the supply ductwork to the furnace duct flanges. A removable access panel should be provided in the outlet duct such that smoke or reflected light would be observable inside the casing to indicate the presence of leaks in the heat exchanger. This access cover shall be attached in such a manner as to prevent leaks. Flexible duct connectors are recommended to connect both the supply and return ducts to the furnace.

Return air ductwork flanges are provided at the top of the unit. Before connecting the return air ductwork to the furnace, refer to the "Filters" section of this instruction. The supply air ductwork connects to the bottom of the furnace.

When the return duct system is not complete, the return connection must be run full size from the furnace to a location outside the utility room or basement. For further details, consult Section 5.3, Air Combustion and Ventilation of the National Fuel Gas Code, ANSI Z223.1 or CAN1-B149.1 or .2 Installation Code (latest editions).

FILTERS

Two 14" x 20" x 1" permanent washable filters are supplied with each unit. Downflow furnace filters are installed above the furnace, extending into the ductwork as shown in Figure 1. Branch ducts must enter above the height of dimension FH.

650.65-N3

The filter rack should be secured to the center of the front and rear flanges at the furnace's return air opening. Drill a hole through the rear duct flange into the filter rack and secure it with a sheet metal screw.

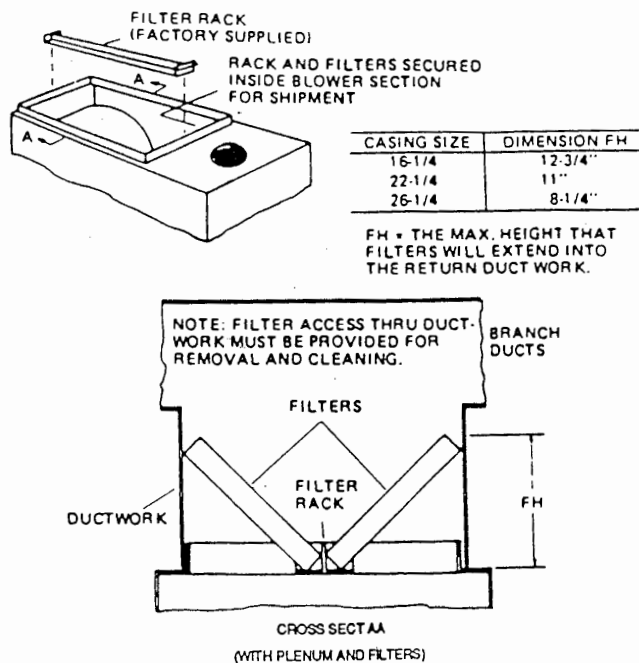

FIGURE 1 - DOWNFLOW FILTERS

COMBUSTION AIR/VENT PIPE SIZING

Refer to Table 2 to select the proper size piping for combustion air intake and venting. The size will be determined by a combination of furnace model, total length of run, and the number of elbows required. The following rules must also be observed.

1. Long radius elbows are recommended for all units.
2. Elbows are assumed to be 90 degrees. Two 45 degree elbows count as one 90 degree elbow.
3. Elbow count refers to combustion air piping and vent piping separately. For example, if the table allows for 5 elbows, this will allow a maximum of 5 elbows in the combustion air piping and a maximum of 5 elbows in the vent piping.
4. The inlet air elbow and accessory vent terminal kit parts are already accounted for, and should not be counted in the allowable total indicated in the table.
5. Combustion air and vent piping must be of the same diameter.

6. All piping and fittings are to be Schedule 40 PVC, PVC-DWV, ABS-DWV, SDR-21 PVC, or SDR-26 PVC.

COMBUSTION AIR INTAKE

All models are provided with a 2" diameter intake elbow.

VENT PIPE CONNECTIONS

All models are provided with a 2" diameter vent pipe.

With reference to the piping sizing table, where units are installed with a vent pipe of a different diameter than the inlet and exhaust, reduction or expansion fittings must be incorporated by the installer at the time of installation, external to the furnace.

PIPING ASSEMBLY

The final assembly procedure for the vent/combustion air piping is as follows:

1. Cut piping to the proper length, beginning at the furnace.
2. Remove burrs from inside and outside the piping.
3. Chamfer the outer edges of the piping.
4. Dry-fit the entire vent/combustion air piping assembly.
5. Disassemble the piping and apply cement primer and cement per the cement manufacturer's instructions. Primer and cement must conform to ASTM D2564 for PVC, or ASTM D2235 for ABS piping.

WARNING: Solvent cements are flammable and must be used in well-ventilated areas only. Keep them away from heat, sparks and open flames (including pilots). Do not breathe vapors and avoid contact with skin and eyes.

6. All joints must be made to provide a permanent, air-tight, water-tight seal. The only exception to this means of joining is where the exhaust is joined to the venter assembly. This joint should be made with RTV sealant. A stainless steel screw must be used in the hole in the venter housing to keep the street elbow in proper alignment.

WARNING: Never operate furnace without the exhaust joined to the venter assembly with a stainless steel screw and sealed with RTV sealant.

If the intake elbow is used for right side exit, carefully remove the plastic cap which is factory installed on the upper left vent connection.

TABLE 2 - COMBUSTION AIR/VENT PIPE SIZES

MODEL	Pipe Size	MAXIMUM ELBOWS PER TOTAL RUN						
		0-5 feet	5-10 feet	10-15 feet	15-20 feet	20-25 feet	25-30 feet	30-35 feet
PAND-LD10N060	1-1/2" 2"	3	2	Note 1	Note 1	Note 1	Note 1	Note 1
		5	5	5	5	5	5	5
PAND-LD12N080	1-1/2" 2"	3	2	Note 1	Note 1	Note 1	Note 1	Note 1
		5	5	5	5	5	5	5
PAND-LD16N100	3"	5	5	5	5	5	5	5
PAND-LD20N120	3"	5	5	5	5	5	5	5

Move the tubing and clamp from the upper right connection to the upper left connection. Place the plastic cap onto the upper right connection.

- Support the combustion air and vent piping such that it is angled at least 1/4" per linear foot upward from the furnace. Piping must be supported with pipe hangers to prevent sagging. Maximum spacing between hangers is five (5) feet, except SDR-PVC piping, where maximum spacing is three (3) feet.
- Seal around the openings where the combustion air and vent piping pass through the roof or side wall.

CAUTION: Vent piping must be insulated with 1/2" Armaflex insulation if it will be subjected to freezing temperatures such as routing through unheated areas or through an unused chimney.

The combustion air piping must be insulated with 1/2" thick Armaflex insulation if it is installed above a suspended ceiling or in a warm, humid space such as a laundry room to prevent possible condensation from forming on the outside of the pipe.

VENT TERMINAL ASSEMBLY

The combustion air and vent piping must terminate outdoors using an accessory Vent Terminal Assembly Kit.

Two vent terminal kits are available. The 1VK0307 kit is to be used with 1-1/2" and 2" piping, and the 1VK0308 is to be used for 3" piping.

NOTE: The 3" vent terminal kit contains one elbow having a "splitter baffle" in one opening. This elbow must be used for the combustion air intake.

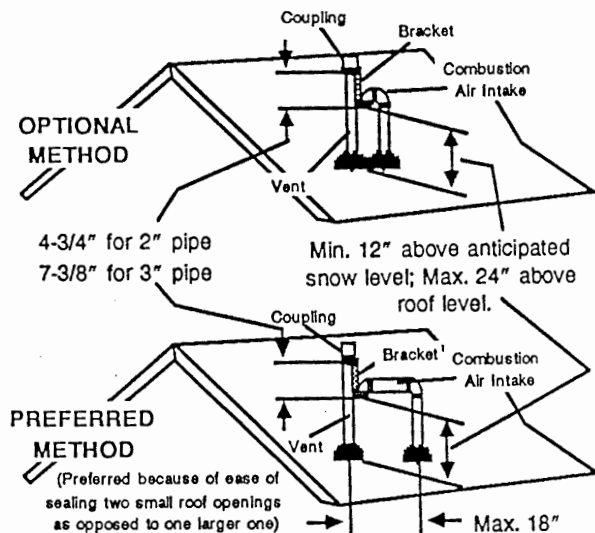

FIGURE 2 - ROOFTOP TERMINATION

Each kit contains the following components:

- One terminal bracket with 2 - 90 degree PVC elbows.
- One 90 degree PVC street elbow.
- One 90 degree PVC elbow.
- One PVC pipe coupling.
- Installation instructions.

Central Environmental Systems

This terminal kit may be used for rooftop or side wall installation. Rooftop termination is the recommended means, and should be arranged according to one of the methods shown in Figure 2.

NOTE: The vent terminal kit and exposed piping may be painted the same color as the building to make them less noticeable.

If optional side wall venting is to be used, installation of the terminal kit should be as shown in Figure 3.

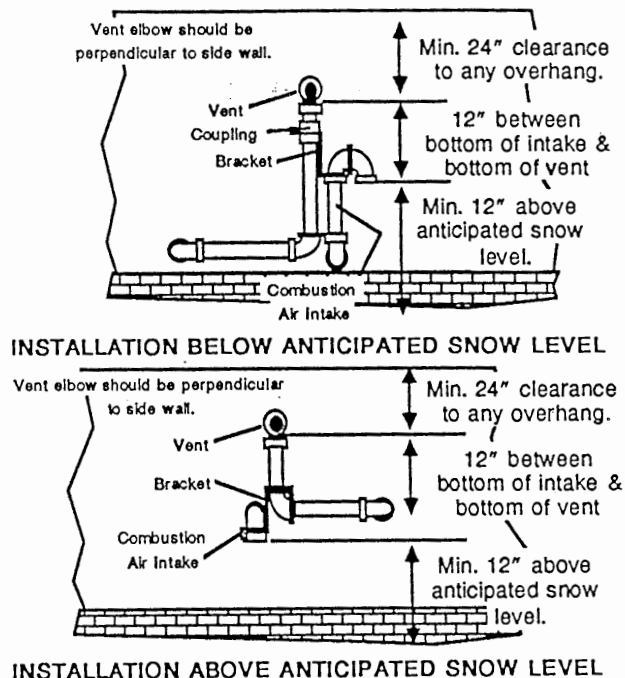

FIGURE 3 - SIDE WALL TERMINATION

If for some reason, combustion air and vent piping can not be routed together, the optional side wall termination may be carried out as illustrated in Figure 4.

The installation procedure for the terminal kit is as follows:

- Cut all combustion air and vent piping so the vent termination fittings and brackets can be dry-fitted together.
- All piping should be free of burrs inside and out, and the outside edge should be chamfered.
- Reassembly all piping and fittings using cement primer and cement per the cement manufacturer's instructions. Primer and cement must conform to ASTM 2564 for PVC or ASTM D2235 for ABS piping.
- Reattach and tighten the vent termination bracket.

GAS PIPING

NOTE: An accessible manual shutoff valve must be installed upstream of the furnace gas controls and within 6 feet of the furnace. A 1/8" NPT plugged tapping, accessible for test gauge connection must be installed immediately upstream of the gas supply connection to the furnace.

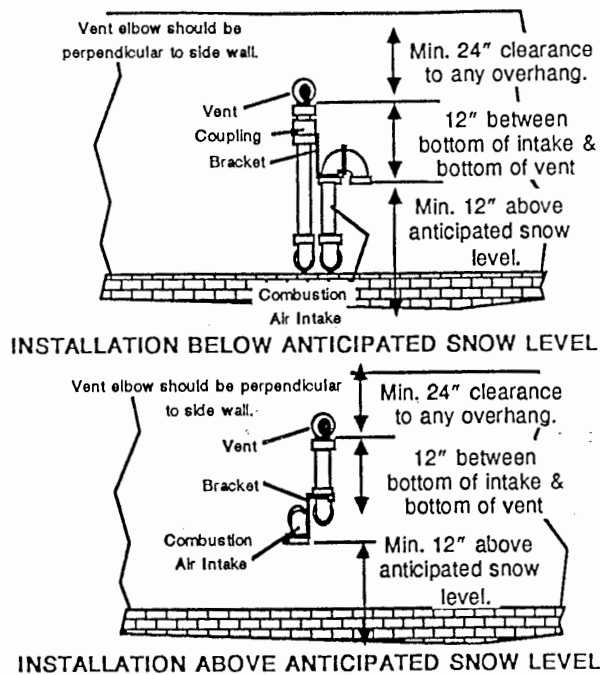

FIGURE 4 - ALTERNATIVE TERMINATIONS

The furnace and its individual shutoff valve must be disconnected from the gas supply piping system during any pressure testing of that system at test pressures in excess of 1/2 psig (3.48 kPa).

The furnace must be isolated from the gas supply piping system by closing its Individual external manual shutoff valve during any pressure testing of the gas supply piping system at pressures equal to or less than 1/2 psig (3.48 kPa).

Gas piping may be connected from either side of the furnace. Sizing and installation of the supply gas line should comply with the local utility requirements. The gas supply should be a separate line, installed in accordance with the National Fuel Gas Code, ANSI Z223.1 or CAN1-B149.1 or .2 Installation Codes (latest editions).

Some utility companies require pipe sizes larger than the maximum sizes listed. Using the properly sized wrought iron, steel or approved flexible pipe, make gas connections to the

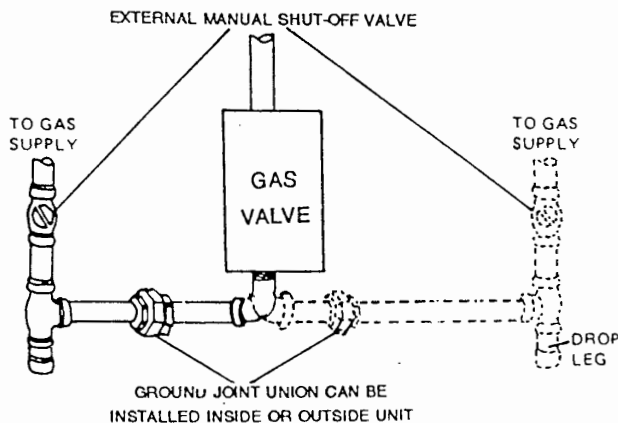

FIGURE 5 - GAS PIPING -

unit. Installation of a drop leg and ground union joint is required (see Figure 5).

WARNING: Compounds used on threaded joints of gas piping must be resistant to the action of liquified petroleum gases. After connections are made, leak-test all pipe connections.

WARNING: Do not use an open flame or other source of ignition for leak testing. Set the manual gas valve to the OFF position.

For the purpose of input adjustment, the minimum inlet gas pressure must be equal to or greater than that shown on the rating label.

CONDENSATE PIPING

The condensate drain connection assembly is located in the lower right front corner of the burner compartment. It consists of a mounting bracket and 1/2" CPVC coupling (ASTM D2846) with flexible tubing connected to it.

The installation procedure for condensate piping is as follows:

1. Determine whether the condensate drain line will be installed through the right or left side of the furnace.
2. Carefully remove the 3/4" diameter knockout from the appropriate side of the furnace. Knockouts are provided on each side.
3. For left side or alternate drain connection, it will be necessary to relocate the condensate drain connection.
 - a. Remove the two screws that secure the drain connection bracket to the right side panel .
 - b. Position the bracket over the corresponding holes in the left side panel , and fasten it to the side panel using the two screws previously removed.
 - c. Make sure the flexible tubing between the drain trap and the drain connection assembly has a continuous downward slope to the drain connection assembly, has no low spots, and is not kinked. (If necessary, shorten the flexible tubing to prevent kinking and/or low spots that could restrict the flow of condensate).
4. Connect field-supplied piping to the condensate drain connection assembly and run it to an open drain. Refer to the "Vent/Combustion Air Connections" section of this instruction for procedure for assembly of plastic pipe. All field piping must be at least 1/2" CPVC and comply with ASTM D2846 (5/8" O.D. x 1/2" I.D.). The condensate piping may be tied together with the air conditioning condensate drain if the air conditioning condensate drain line is trapped upstream of the tie-in and the combined drains are constructed of CPVC piping. Where necessary, an accessory condensate pump may be used.
5. All pipe joints must be properly cemented using CPVC primer and cement that conforms to ASTM F493.
6. The furnace contains an internal trap. Therefore, no external trap should be used.

7. If a condensate pump is used, it must be suitable for use with acidic water.
8. Where required, an accessory neutralizer can be installed in the drain line, external to the furnace.

VENT PIPE CONDENSATE DRAIN

In some applications, condensate may form in the vent pipe as it passes through spaces cooler than the flue gas temperature. Figure 6 shows a recommended installation of a condensate tee trap to provide for removal of condensate from the venting system.

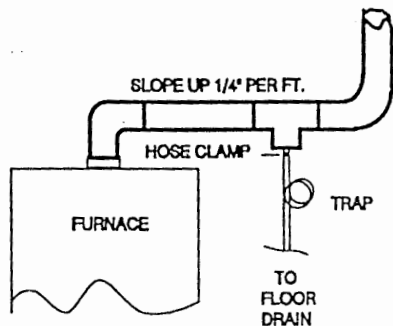

FIGURE 6 - VENT CONDENSATE DRAIN

ELECTRICAL DATA

Use copper conductors only!

Field wiring to the unit must conform to and be grounded in accordance with the provisions of the National Electrical Code ANSI/NFPA No. 70-1987, Canadian Electric Code C22.1, Part 1 and/or local codes.

Electric wires which are field installed shall conform with the temperature limitation for 63°F/35°C rise wire when installed in accordance with instructions. Specific electrical data is given for the furnace on its rating plate and in Table 1 of this instruction.

ELECTRICAL CONNECTIONS

The furnace's control system depends on correct polarity of the power supply. Connect the power supply as shown on the unit wiring label on the inside of the blower compartment door.

Provide a power supply separate from all other circuits. Install overcurrent protection and disconnect switch per local/national electrical codes.

The switch should be reasonably close to the unit for convenience in servicing. With the disconnect switch in the OFF position, check all wiring against the unit wiring label. Also, see the wiring diagram in this instruction.

Install the field-supplied thermostat. The thermostat instructions for wiring are packed with the thermostat. With the thermostat in the OFF position and the main electrical source disconnected, complete the low voltage wiring from the thermostat to the terminal. Set the heat anticipator on the thermostat to .36 amps.

NOTE: Some thermostats do not have adjustable anticipators. On such thermostats, adjust cycle rate to prevent possible short on/off cycles.

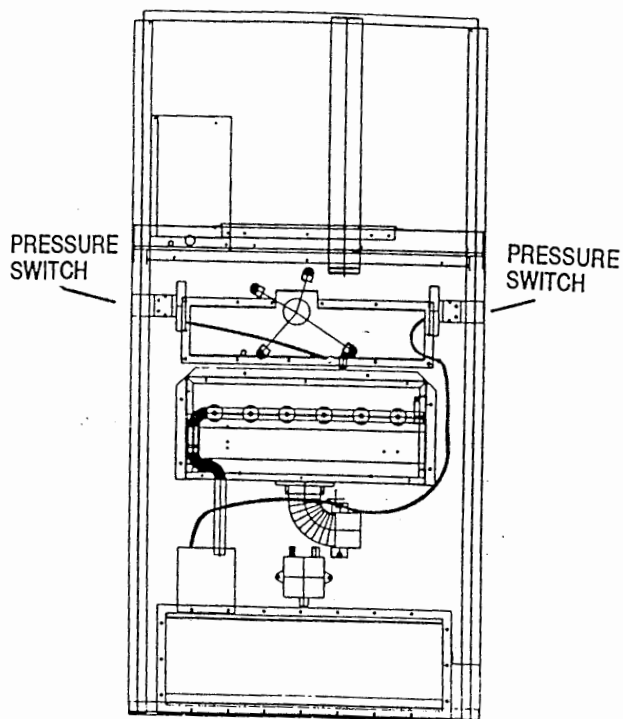

FIGURE 7 - PRESURE SWITCH TUBING

SAFETY CONTROLS

Interlock Switch

This unit is equipped with an electrical interlock switch mounted in the blower compartment.

This switch interrupts power at the unit when the panel covering the blower compartment is removed. This prevents operation of the automatic gas control valve and the blower.

WARNING: Blower and burner must never be operated without the blower panel in place.

Electrical supply to this unit is dependent upon the panel that covers the blower compartment being in place and properly positioned.

CAUTION: Main power to the unit must still be interrupted at the main power disconnect switch before any service or repair work is to be done to the unit. Do not rely upon the interlock switch as a main power disconnect.

Pressure Switches

This furnace is supplied with pressure switches which monitor the flow through the combustion air/vent piping system. The tubing and switch configuration is shown in Figure 7. These switches de-energize the ignition control module and the gas valve if any of the following conditions are present.

1. Blockage of combustion air piping or terminal.
2. Blockage of vent piping or terminal.
3. Failure of combustion air blower motor.
4. Blockage of condensate drain piping.

START-UP AND ADJUSTMENTS

The initial start-up of the furnace requires the following additional procedures:

1. When the gas supply is initially connected to the furnace, the gas piping may be full of air. In order to purge this air, it is recommended that the ground union be loosened until the odor of gas is detected. When gas is detected, immediately retighten the union and check for leaks. Allow five minutes for any gas to dissipate before continuing with the start-up procedure.

WARNING: Be sure proper ventilation is available to dilute and carry away any vented gas.

2. The condensate trap must be filled with water before putting the furnace into operation. The recommended procedure is as follows:
 - a. Disconnect the condensate drain hose from the condensate drain outlet fitting.
 - b. Elevate this hose above trap level and fill with water using a funnel. Drain excess water into a container.
 - c. Replace the condensate drain hose and clamps.
3. All electrical connections made in the field and in the factory should be checked for proper tightness.

IGNITION SYSTEM CHECKOUT/ADJUSTMENT

1. Turn the gas supply ON at external valve and main gas valve.
2. Set the thermostat above room temperature to call for heat.
3. System start-up will occur as follows:
 - a. Venter motor will start and come up to speed. Shortly after venter start-up, the hot surface igniter will glow for about 17 seconds.
 - b. After warm-up cycle, ignition module will energize (open) the main gas valve for seven seconds.

NOTE: Burner ignition may not be satisfactory on first start-up due to residual air in gas line, or until gas pressure (manifold) is adjusted.

6. With furnace in operation, paint the pipe joints and valve gasket lines with a rich soap and water solution. Bubbles indicate a gas leak. Take appropriate steps to stop the leaks. If the leak persists, replace the component.

WARNING: DO NOT omit this test! NEVER use a flame to check for gas leaks.

ADJUSTMENT OF MANIFOLD GAS PRESSURE

1. Turn gas off at main gas valve. Remove 1/8" plug in the main gas valve body and install proper manometer tube adapter fitting. Connect line from gas valve tap to manometer

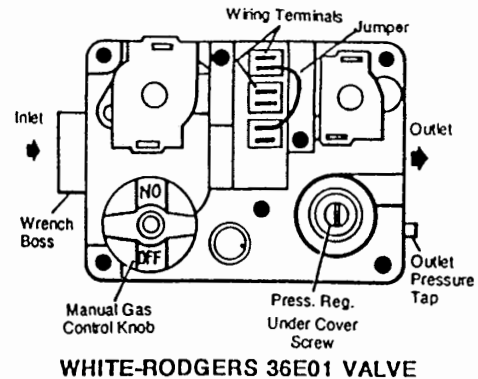

WHITE-RODGERS 36E01 VALVE

FIGURE 8 - GAS VALVE

2. Refer to Figure 8 for location of pressure regulator adjustment cap and screw on main gas valve.

NOTE: The screw-off cap for the pressure regulator must be removed entirely to gain access to the adjustment screw.

WARNING: The cap must be replaced in order for the furnace to operate properly.

3. Turn gas and electrical supplies ON. Start furnace and observe manifold pressure on manometer.
4. Adjust manifold pressure by adjusting gas valve regulator screw: for natural gas, set at 3.5" W.C.; for propane (LP) gas, set at 10.0" W.C.

WARNING: The manifold pressure must be checked with the screw-off cap in place on the pressure regulator.

WARNING: If manifold pressure is too high, an over-fire condition exists which could cause heat exchanger failure. If the manifold pressure is too low, sooting and eventual clogging of the heat exchanger could occur.

If gas valve regulator is turned in, or clockwise, manifold pressure is increased. If screw is turned out, or counterclockwise, manifold pressure will decrease.

WARNING: Once the correct gas pressure to the burners has been established, turn the gas valve knob to OFF and turn the electrical supply switch to OFF; then remove the pressure tap at the gas valve and re-install the plug, using a compound (on the threads) resistant to the action of LP gases.

Turn the electrical and gas supplies back on, and with the burners in operation, check for gas leakage around the plug with a soap and water solution.

ELECTRONIC AIR CLEANER CONNECTION

Two 1/4" spade terminals (AC and AC N) are located on the 50A50 control for electronic air cleaner connections. The terminals provide 115 VAC (1.0 amp maximum) during circulating blower operation.

HUMIDIFIER CONNECTION

Two 1/4" spade terminals (HUM and HUM N) are located on the 50A50 control for humidifier connection. The terminals provide 115 VAC (1.0 amp maximum) during heat speed operation of the circulating blower.

ADJUSTMENT OF FAN-OFF CONTROL SETTINGS

The fan-off setting must be long enough to adequately cool the furnace, but not so long that cold air is blown into the heated space. The fan-off timing may be adjusted by setting the option switches located (see Figure 9) on the 50A50 module as follows:

OPTION SWITCH POSITIONS		
To Delay Fan-Off By:	Set Switch	
	1	2
60 Sec.	On	On
90 Sec.	Off	On
120 Sec.	On	Off
180 Sec.	Off	Off

Factory set at 30 sec. on and 60 sec. off (adjustable)

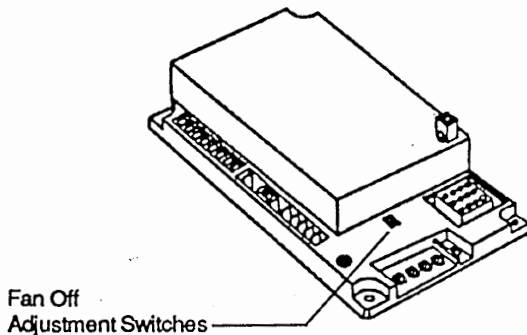

FIGURE 9 - LOCATION OF FAN OFF ADJUSTMENT

CHECKING GAS INPUT (NATURAL GAS)

NOTE: Front door of burner box must be secured when checking gas input.

1. Turn off all other gas appliances connected to the gas meter.
2. With the furnace turned on, measure the time needed for one revolution of the hand on the smallest dial on the meter. A typical domestic gas meter usually has a 1/2 or 1 cubic foot test dial.
3. Using the number of seconds for each revolution and the size of the test dial increment, find the cubic feet of gas consumed per hour from Table 3.

NOTE: To find the Btuh input, multiply the number of cubic feet of gas consumed per hour by the BTU content of the gas in your particular locality. Contact your gas company for this information, as it varies widely from city to city.

EXAMPLE: It is found by measurement that it takes 26 seconds for the hand on the 1 cubic foot dial to make a revolution with only a 120,000 Btuh furnace running. Using this information, locate 26 seconds in the first column of Table 3. Read across to the column headed "1 cubic foot" where you will see that 138 cubic feet of gas per hour are consumed by the furnace at that rate. Multiply 138 by 850 (the BTU rating of the gas obtained from the local gas company). The result is 117,300 Btuh, which is close to the 120,000 Btuh rating of the furnace.

If the actual input is not within 5% of the furnace rating, with allowance being made for the permissible range of the regulator setting (0.3 inches W.C.), replace the orifice spuds with spuds of the proper size.

TABLE 3 - GAS RATE (CUBIC FEET PER HOUR)

Seconds for one Revolution	Size of Test Dial	
	1/2 Cubic Ft.	1 cubic ft.
10	180	360
12	150	300
14	129	257
16	113	225
18	100	200
20	90	180
22	82	164
24	75	150
26	69	138
28	64	129
30	60	120
32	56	113
34	53	106
36	50	100
38	47	95
40	45	90
42	43	86
44	41	82
46	39	78
48	37	75
50	36	72
52	35	69
54	34	67
56	32	64
58	31	62
60	30	60

CAUTION: Be sure to relight any gas appliances that were turned off at the start of this input check.

ADJUSTMENT OF TEMPERATURE RISE

The temperature rise, or temperature difference between the return air and the heated air from the furnace, must be within the range shown on the furnace rating plate and within the application limitations shown in Table 1. After the temperature rise has been determined, the cfm can be calculated.

After about 20 minutes of operation, determine the furnace temperature rise. Take readings of both the return air and the heated air in the ducts, about six feet from the furnace where they will not be affected by radiant heat. Increase the blower speed to decrease the temperature rise; decrease the blower speed to increase the rise.

All direct-drive blowers have multi-speed blowers. Refer to the unit wiring diagram and connect the blower motor for the desired speed. The blower motor speed taps are located in the control box in the blower compartment.

OPERATION & MAINTENANCE

SEQUENCE OF OPERATION

Hot Surface Ignition System

WARNING: Do not attempt to light this furnace by hand (with a match or any other means). There may be a potential shock hazard from the components of the hot surface ignition system. The furnace can only be lit automatically by its hot surface ignition system.

The following describes the sequence of operation of the furnace. Refer to the schematic wiring diagram (page 14) for component location.

Continuous Blower

On the cooling/heating thermostats with fan switch, when the fan switch is set in the ON position, a circuit is completed between terminals R and G of the thermostat. The motor is energized through the black, high-speed tap. The blower then operates on high speed.

Intermittent Blower

When the system switch is set on HEAT and the fan switch is set on AUTO, and the room thermostat calls for heat, a circuit is completed between terminals R and W of the thermostat. When the proper amount of combustion air is being provided, a pressure switch activates the 50A50 ignition control. A second pressure switch (2LP-1 or 2LP-2) and the limit are in this circuit, and must be in the closed position for the ignition control to be activated.

The 50A50 ignition control provides a 17-second warm-up period. The gas valve then opens for seven seconds.

As gas starts to flow and ignition occurs, the flame sensor begins its sensing function. If a flame is detected within seven seconds after ignition, normal furnace operation continues until the thermostat circuit between R and W is opened. After flame is present for 30 seconds, the circulating blower is energized.

When the thermostat circuit opens, the ignition control is deenergized. With the ignition control deenergized, the gas flow stops and the burner flames are extinguished. The venter continues to operate for 15 seconds after the gas flow stops.

The blower motor continues to operate for the amount of time set by the fan-off delay dip switches on the ignition control module. The heating cycle is then complete, and the unit is ready for the start of the next heating cycle.

If flame is not detected within the seven second sensing period, the gas valve is de-energized. The 50A50 control is equipped with a re-try option. This provides a 60-second wait following an unsuccessful ignition attempt (flame not detected).

After the 60 second wait, the ignition sequence is restarted with an additional 10 seconds of igniter warm-up time. If this ignition attempt is unsuccessful, one more re-try will be made before lockout.

50A50 HOT SURFACE IGNITION CONTROL

All 50A50 controls will repeat the ignition sequence for a total of four recycles if flame is lost within the first 10 seconds of establishment.

If flame is established for more than 10 seconds after ignition, the controller will clear the ignition attempt (re-try) counter. If flame is lost after 10 seconds, it will restart the ignition sequence. This can occur a maximum of five times.

During burner operation, a momentary loss of power of 50 milliseconds or longer will drop out the main gas valve. When the power is restored, the gas valve will remain de-energized, and a restart of the ignition sequence will begin immediately.

A momentary loss of gas supply, flame blowout, or a shorted or open condition in the flame probe circuit will be sensed within 0.8 seconds. The gas valve will de-energize and the control will restart the ignition sequence after waiting 60 seconds. Recycles will begin and the burner will operate normally if the gas supply returns, or the fault condition is corrected prior to the last ignition attempt. Otherwise, the control will lockout.

If the control is locked out, it may be reset by momentary power interruption of 1/20 second or longer. Either the 24v thermostat or line voltage may be interrupted.

MAINTENANCE

The manufacturer recommends that maintenance is performed by a qualified service agency for cleaning vent/air intakes, condensate drains and neutralizers, burners, primary and secondary heat exchangers and the blower motor and wheel assembly. An annual inspection of these components is recommended.

Air Filters

The filters should be checked periodically for dirt accumulation. Dirty filters greatly restrict the flow of air and overburden the system.

Clean the filters at least every three months. See page 5 for filter removal instructions. On new construction, check the filters every week for the first four weeks. Inspect the filters at least every three weeks after that, especially if the system is running constantly.

Air filters supplied with the furnace are the high-velocity, cleanable type. Clean these filters by washing in warm water. Make sure to shake all the water out of the filter and have it reasonable dry before installing it in the furnace. When replacing filters, be sure to use the same size and type as originally supplied.

Lubrication

Blower motors in these furnaces are permanently lubricated and do not require periodic oiling.

Burner Removal/Cleaning

The main burners should be checked periodically for dirt accumulation.

If cleaning is required, follow the steps listed below:

1. Turn off the electrical power to the unit.
2. Remove the lower access door.
3. Remove the front cover of the burner box.
4. Vacuum the burner assembly to remove dirt or dust.

Cleaning the Primary Heat Exchanger

1. Turn off the main manual gas valve external to the furnace.
2. Turn off the electrical power to the furnace.
3. Remove the access door.
4. Disconnect the gas supply piping and control wiring from the gas valve.
5. Remove the front cover of the burner box.

6. Remove the screws holding the burner box assembly to the vestibule panel.
7. Remove the burner box assembly.
8. To reach the lower portion of the heat exchanger, remove the flue box cover and flue baffles.
9. With a stiff wire brush, brush out loose scale or soot.
10. Vacuum the burner assembly and heat exchanger.
11. Replace all parts removed for cleaning by reversing the order of disassembly.
12. Reconnect all wiring and gas piping.
13. Restore electrical power and gas supply to the furnace.

Cleaning the Secondary Heat Exchanger

1. Remove the screw in the venter outlet. Disconnect the drain lines from the venter and from the condensate drain pan. Remove the venter blower and the condensate pan.
2. With a stiff wire brush, brush out loose scale or soot.
3. Vacuum the secondary heat exchanger.
4. Replace the condensate pan and drain hose. Replace venter and use RTV sealant to seal vent pipe to venter outlet. Secure vent pipe to venter outlet with stainless steel screw.

WARNING: Never operate furnace without the exhaust joined to the venter assembly with a stainless steel screw and sealed with RTV sealant.

BLOWER CARE

Even with good filters properly in place, blower wheels and motors will become dust laden after long months of operation. The entire blower assembly should be inspected annually. If the motor and wheel are heavily coated with dust, they can be brushed and cleaned with a vacuum cleaner.

The procedure for removing the blower assembly for cleaning is as follows:

1. Disconnect the electrical supply to the furnace.
2. Remove the access panels.
3. Disconnect the two wire harness plugs from the top of the control box.
4. Remove the four screws holding the control box and position it out of the way.
5. Remove screw from outlet of venter housing which holds vent pipe in place. Remove screw securing vent pipe to blower deck and remove vent pipe. Disconnect from field supplied venting.
6. Remove screws which retain blower to the blower deck.

7. Vacuum the motor and the blower wheel using a soft brush attachment. Care must be used not to disturb the balance weights (clips) on the blower wheel vanes.
8. Before reinstalling the blower assembly, inspect the secondary heat exchanger which is visible directly below the blower opening in the blower deck. If it requires cleaning, vacuum it with a soft brush attachment and follow the direction of the fins.
9. Reinstall the blower assembly. Replace the mounting screws that hold the blower assembly to the front portion of the blower deck. The two mounting screws used on the sides of the blower are used for shipping purposes only, and are not necessary after the furnace has been installed.
10. Reinstall the control box and reconnect the wiring harness plugs.
11. Replace vent pipe in venter outlet and seal joint using RTV sealant. Replace stainless steel screw securing vent pipe to venter outlet. Replace stainless steel screw securing vent pipe to blower deck. Reconnect to field supplied vent pipe

WARNING: Never operate furnace without the exhaust vent in place or joined to the venter assembly with a stainless steel screw and sealed with RTV sealant.

12. Replace the access doors and restore the electrical supply to the unit.

TROUBLESHOOTING

The following visual checks should be made before troubleshooting:

1. Check to see that the power to the furnace and the 50A50 control module is ON.
2. The manual shutoff valves in the gas line to the furnace must be open.
3. Make sure all wiring connections are secure.
4. Review the sequence of operation.

Start the system by setting the thermostat above the room temperature. Observe the system's response. Then use the Troubleshooting Table to check the system's operation.

To use the troubleshooting table, begin by reading the upper left-hand box and then following the instructions in each box. If the condition described in the box is true (yes answer), go down to the next box. If the condition is not true (no answer), go to the box to the right. Continue checking and answering the questions in the boxes until the problem is explained and corrective action is described. After any maintenance or repair, the troubleshooting sequence should be repeated until normal system operation is obtained.

WARNING: Do not try to repair controls. Replace defective controls with CES Source 1 Parts.

WIRING DIAGRAM - ALL MODELS

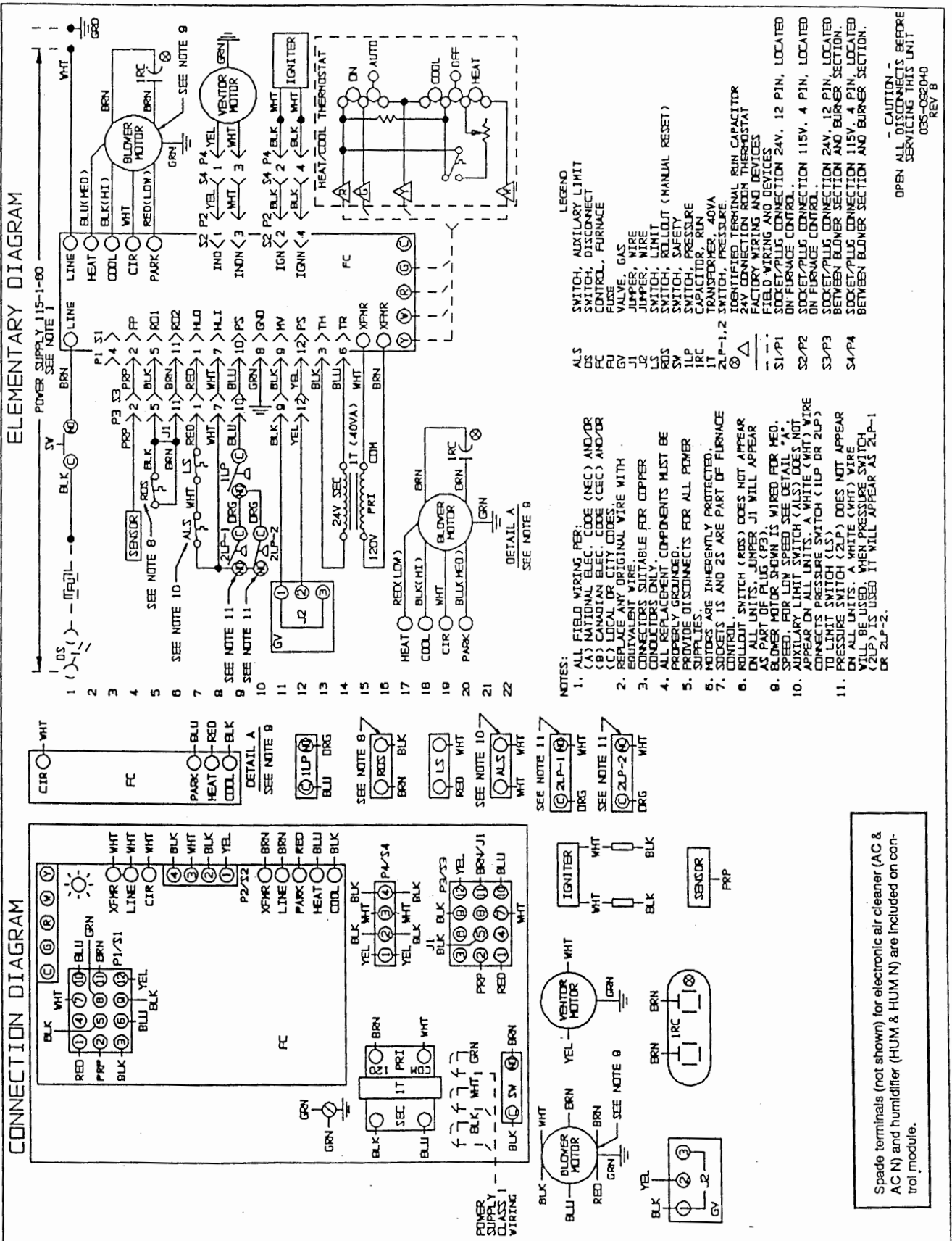

Spade terminals (not shown) for electronic air cleaner (AC & ACN) and humidifier (HUM & HUMN) are included on control module.

WHITE-RODGERS 50A50 TROUBLESHOOTING TABLE

50A50 CONTROL MODULE - CONTINUOUS FAN OPERATION CHECK

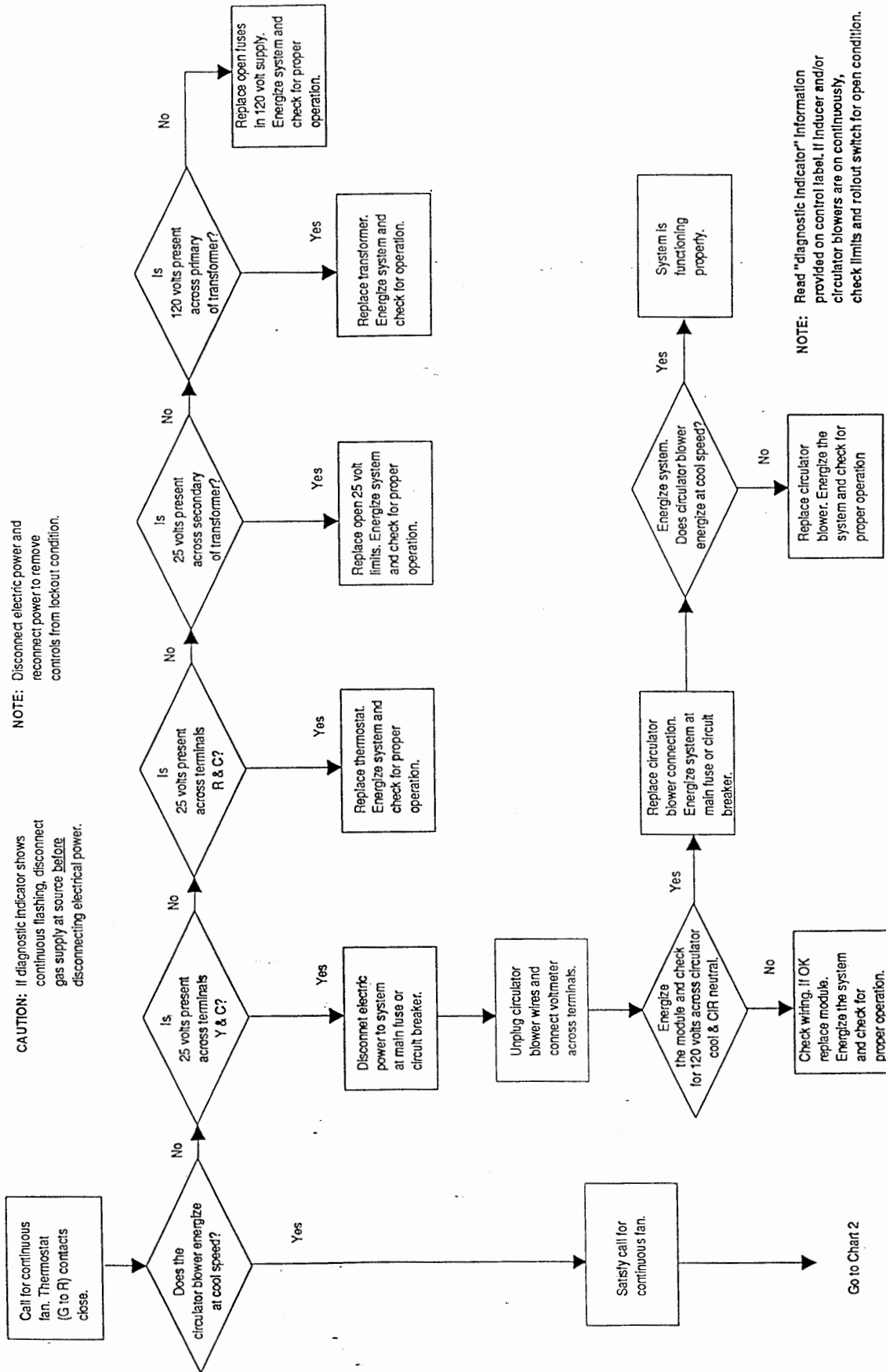

50A50 CONTROL MODULE - COOL OPERATION CHECK

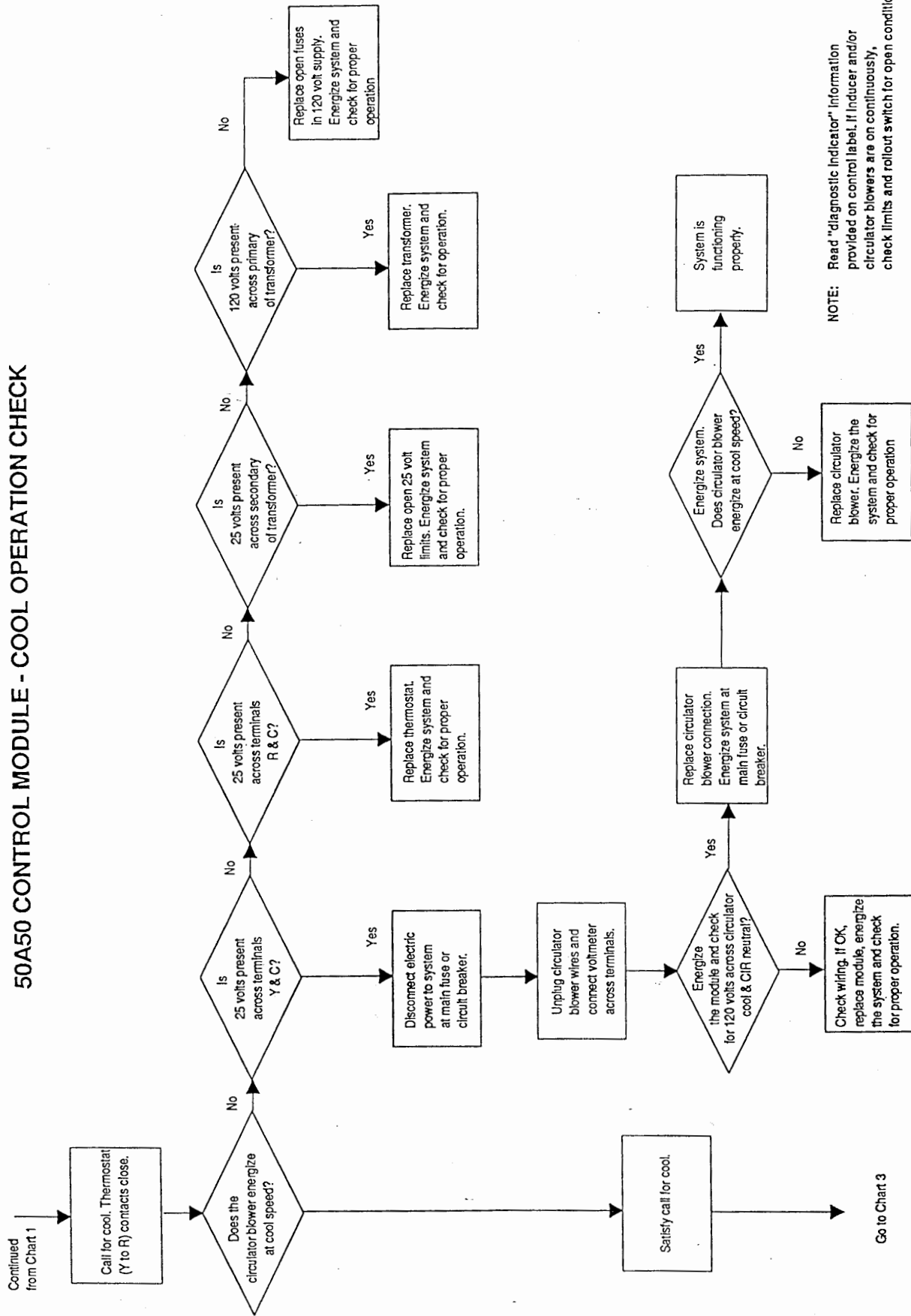

NOTE: Read "diagnostic indicator" information provided on control label. If inducer and/or circulator blowers are on continuously, check limits and rollout switch for open condition.

50A50 CONTROL MODULE - HEAT CYCLE PREPURGE CHECK

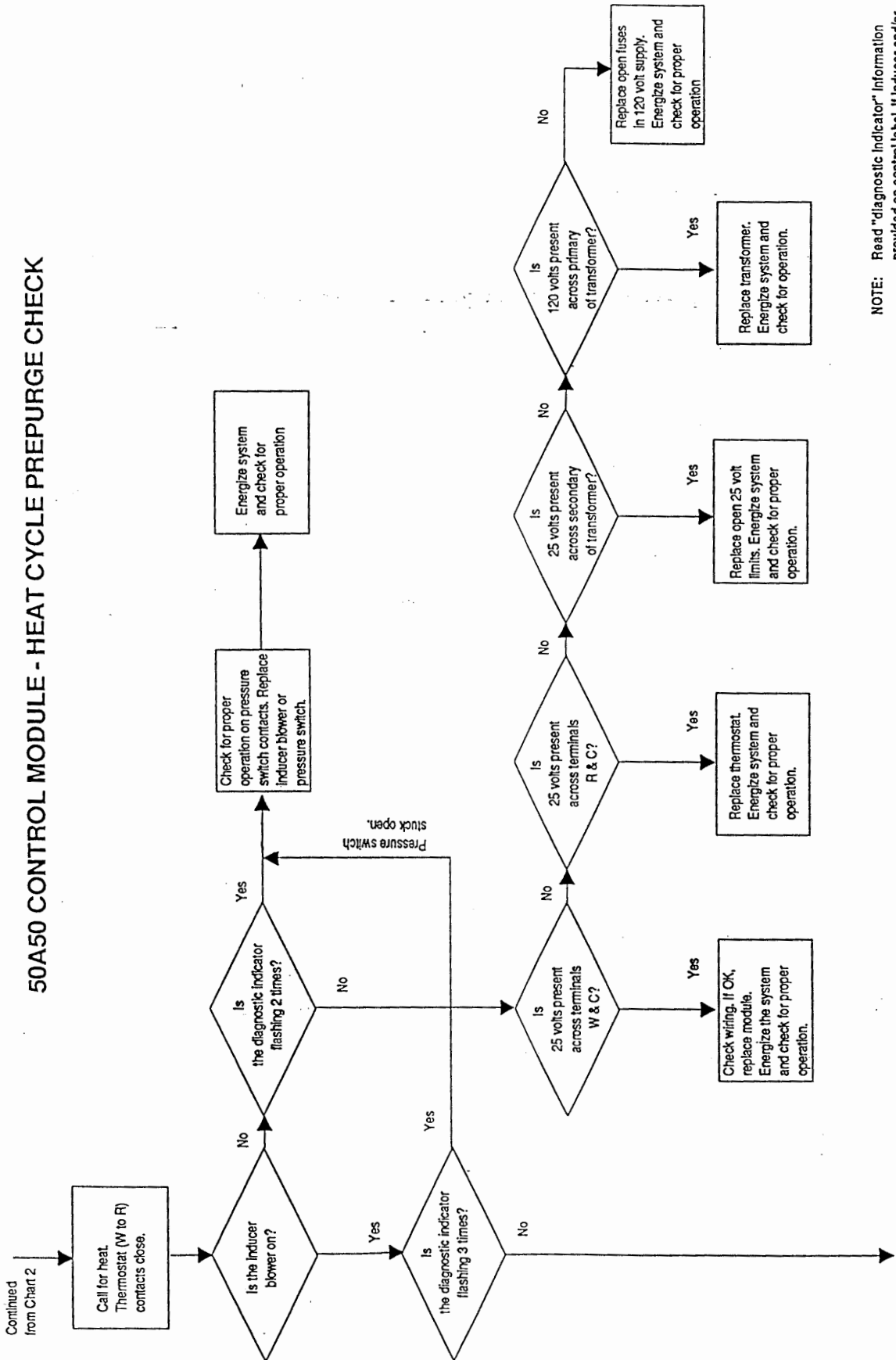

NOTE: Read "diagnostic indicator" information provided on control label. If inducer and/or circulator blowers are on continuously, check limits and rollout switch for open condition.

50A50 CONTROL MODULE - HEAT CYCLE IGNITER WARM-UP CHECK

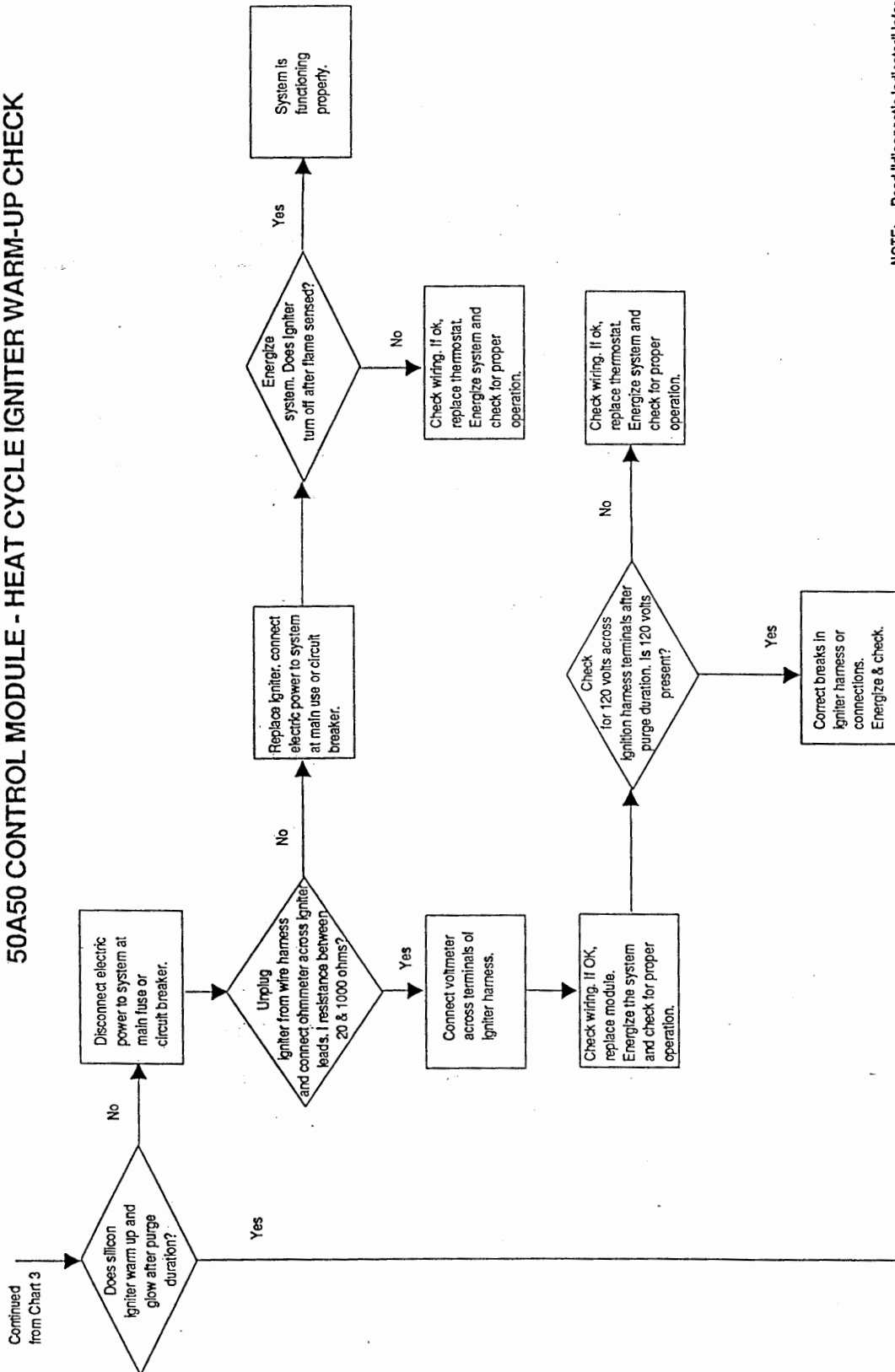

NOTE: Read "diagnostic Indicator" information provided on control label. If inducer and/or circulator blowers are on continuously, check limits and rollout switch for open condition.

50A50 CONTROL MODULE - HEAT CYCLE MAIN BURNER IGNITION CHECK

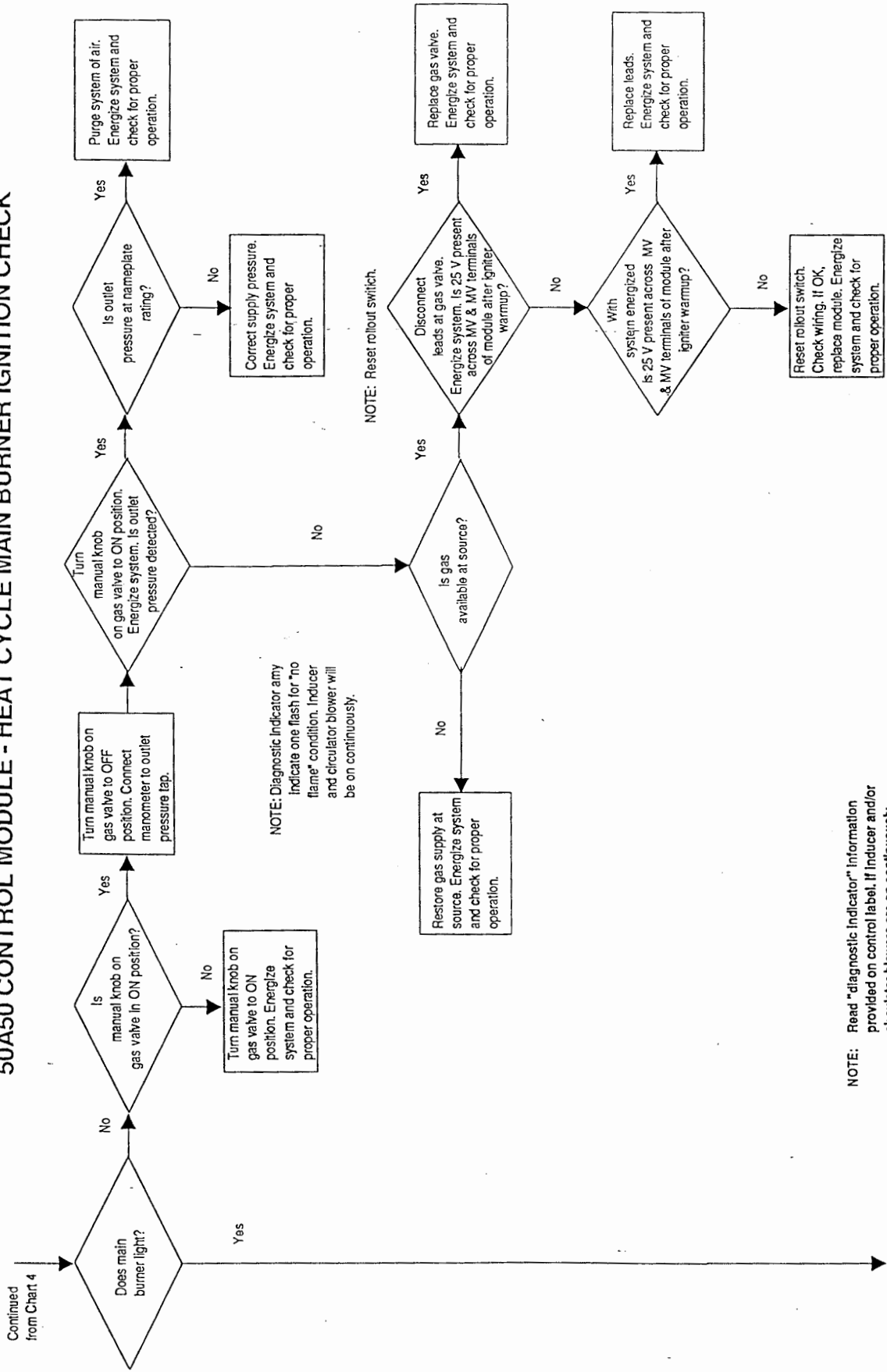

NOTE: Diagnostic Indicator may indicate one flash for "no flame" condition. Inducer and circulator blower will be on continuously.

NOTE: Reset rollout switch.

NOTE: Read "diagnostic Indicator" information provided on control label. If inducer and/or circulator blowers are on continuously, check limits and rollout switch for open condition.

Go to Chart 6

50A50 CONTROL MODULE - HEAT CYCLE - DOES MAIN BURNER REMAIN LIT?

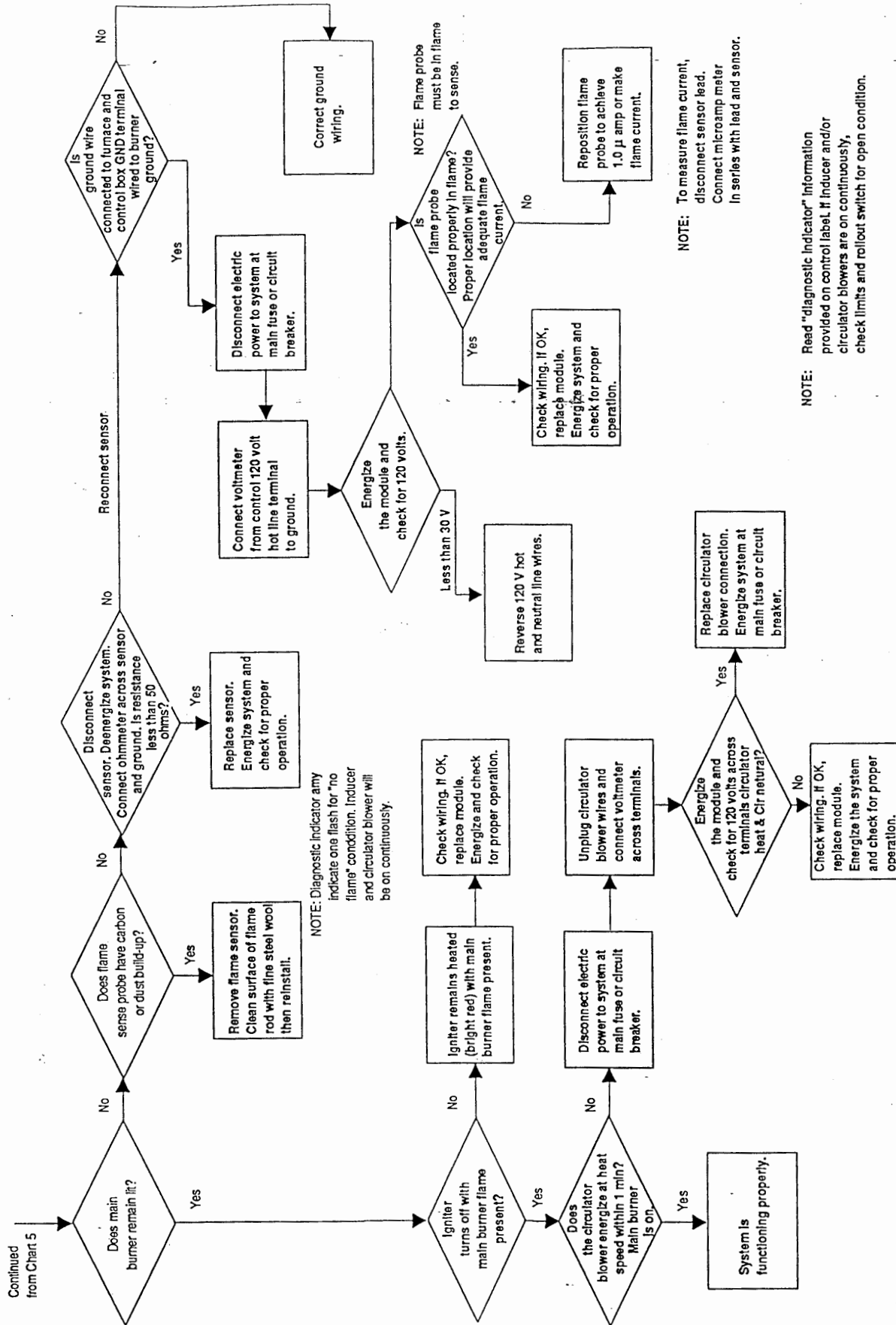



Hamilton Home Products, Inc.

WINCHESTER

(800) 879-0123

WDN SERIES
DOWNFLOW CONDENSING
GAS FURNACE

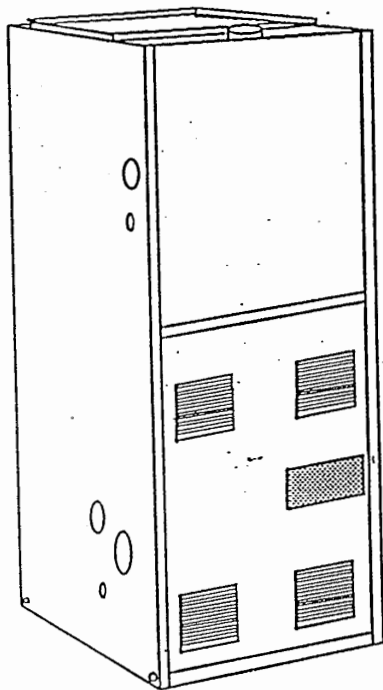

MODEL PAND STYLE A
60-120 MBH INPUT



DESCRIPTION

These Category IV, highly efficient, compact, sealed combustion, condensing type furnaces are designed for residential and commercial installations where the ambient temperature is above 32°F, or higher. All use outdoor combustion air. They may be either side wall or thru-roof vented using approved plastic type combustion air and vent piping. A Vent Termination Kit is required. All units are factory assembled, wired and tested to assure dependable and economical installation and operation.

FEATURES

- Electronic Hot Surface Ignition saves fuel cost with increased dependability and reliability.
- Induced combustion system with Inshot main burners for quiet, efficient operation with low NOx emissions of 35 nanograms/joule.
- 100% shut off main gas valve for extra safety. Propane convertible.
- PSC - multiple speed, direct drive motor with large, quiet blower.
- 24V, 40 VA control transformer and cooling relay supplied for add-on cooling.
- Hi-tech sectionalized primary heat exchanger of aluminized steel.
- Streamlined secondary (condensing) heat exchanger of high-grade stainless steel.
- Lifetime limited warranty on both heat exchangers to the original purchaser; a 20-year limited warranty from original installation date to subsequent purchaser. 20-year warranty on commercial applications.
- Uses outdoor combustion air to reduce internal heat load and drafts along with reduced potential for corrosion caused by contaminated indoor combustion air.
- Timed on / adjustable off blower capability.
- Blower door safety switch and combustion air safety.
- Solid (knock out) bottom to assure rattle free operation.
- Attractively styled with baked-enamel finish.
- Easy access from front of unit for cleaning, maintenance or service.
- Cleanable, high efficiency filters supplied with furnaces.
- Electronic air cleaner and humidifier terminals.

RATINGS AND PHYSICAL DATA

MODEL NUMBER	HTG. CAP. INPUT MBH	SS OUTPUT MBH	AFUE*	CALIF. SEAS. EFF.**	AIR TEMP. RISE °F	CFM @ MEAN AIR TEMP. RISE	MAX. OUTLET AIR TEMP. °F	BLOWER			MAX. OVER-CURRENT PROT.	UNIT AMPACITY	MIN. WIRE (AWG) @ 75'
								DIA.	WIDTH	HP			
PAND-LD10N060	60	57	92.6	88.2	45-75	586	175	10	6	1/2	20	15	14
PAND-LD12N080	80	76	92.6	86.6	45-75	880	175	11	8	1/2	20	15	14
PAND-LD16N100	100	95	92.6	85.9	45-75	1257	175	10	10	1	20	17	12
PAND-LD20N120	120	114	92.6	88.9	45-75	2000	175	11	10	1	20	17	12

- * AFUE numbers are family rated in accordance with DOE test procedures.
- ** As submitted to California Energy Commission.

NOTES: 1. For altitudes above 2000 ft. reduce capacity 4% for each 1000 ft. above sea level.
 2. Wire size based on copper conductors, 60°C, 3% voltage drop.
 3. Continuous return air temperature should not be below 55°F.

MODEL NUMBER	FILTER SIZE	ADD-ON COOLING		APPROX. OPER. WEIGHT
		TONS	CFM* @ .5 ESP	
PAND-LD10N060	14 x 20	2, 2-1/2	896	176
PAND-LD12N080	14 x 20	2-1/2, 3	1041	190
PAND-LD16N100	14 x 20	3, 3-1/2, 4	1300	221
PAND-LD20N120	14 x 20	3-1/2, 4, 5	1307	236

* ESP (External Static Pressure) .5" WG is at furnace outlet ahead of cooling coil.
 NOTE: All filters supplied with furnace are of high velocity cleanable type.

FIELD WIRING DIAGRAM

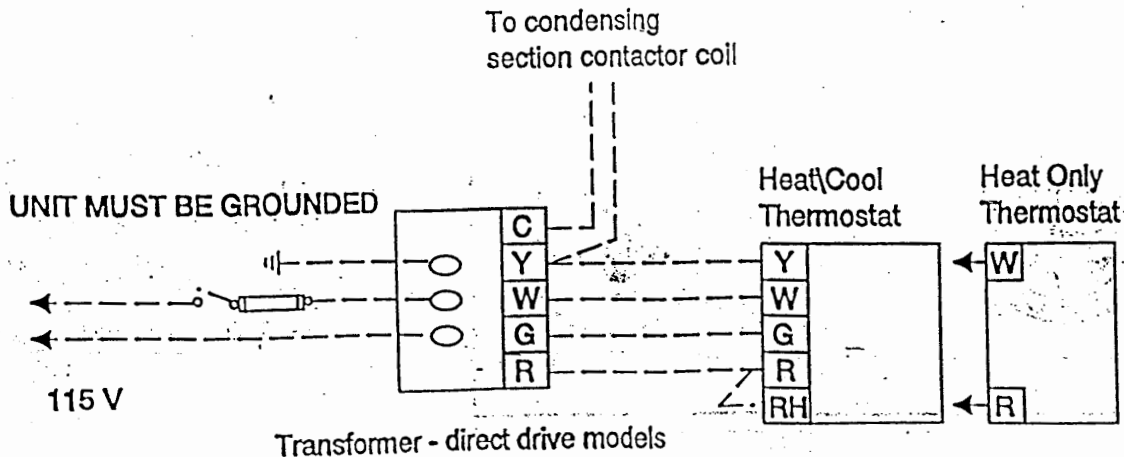

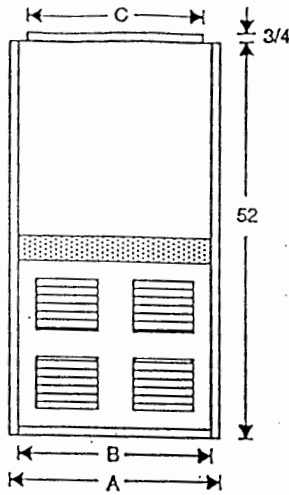

FRONT

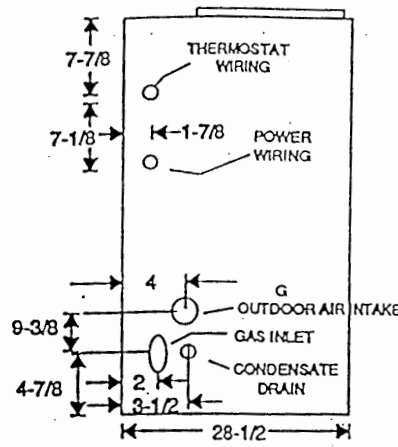

RIGHT SIDE

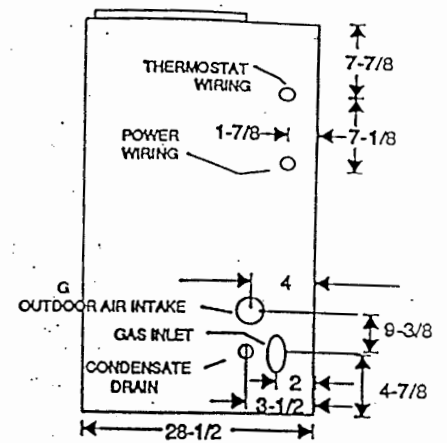

LEFT SIDE

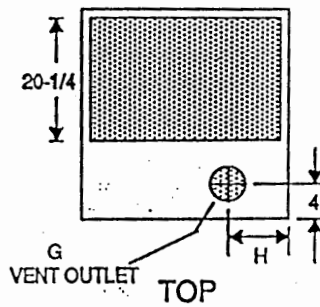

TOP

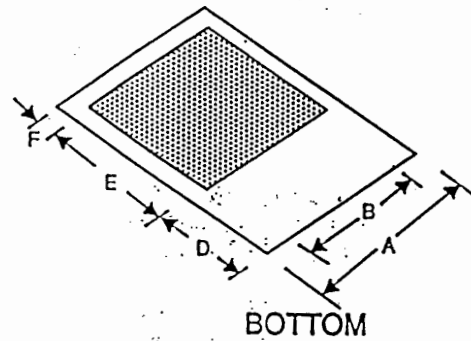

BOTTOM

MODEL	A	B	C	D	E	F	G	H
PAND-LD10N060	16-1/4	14	15	8-5/8	18-3/4	1-1/8	2	5-5/8
PAND-LD12N080	16-1/4	14	15	8-5/8	18-3/4	1-1/8	2	5-5/8
PAND-LD16N100	22-1/4	20	21	8-5/8	18-3/4	1-1/8	2	8-3/8
PAND-LD20N120	26-1/4	24	21	8-5/8	18-3/4	1-1/8	2	10-3/8

All dimensions are in inches, and are approximate. Certified dimensions are available upon request.

VENT SIZING TABLE

MODEL	PIPE SIZE	MAX. ELBOWS PER TOTAL RUN						
		0-5 Feet	5-10 Feet	10-15 Feet	15-20 Feet	20-25	25-30 Feet	30-35 Feet
PAND-LD10N060	1-1/2"	3	2	Note 1	Note 1	Note 1	Note 1	Note 1
	2"	5	5	5	5	5	5	5
PAND-LD12N080	1-1/2"	3	2	Note 1	Note 1	Note 1	Note 1	Note 1
	2"	5	5	5	5	5	5	5
PAND-LD16N100	3"	5	4	5	5	5	5	5
PAND-LD20N120	3"	5	5	5	5	5	5	5

- NOTES: 1. Must use the larger pipe size indicated.
 2. Long radius elbows recommended on these units.

DGD SERIES GAS FURNACES

TECH SPEC

T-789 Rev.2
(4/96)

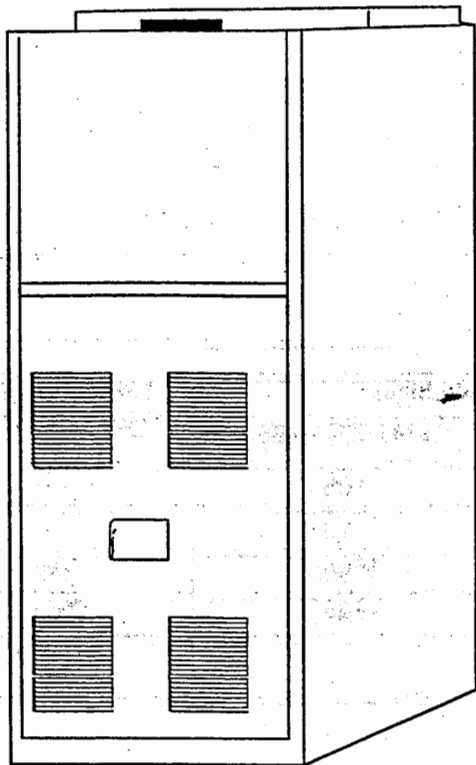

GAS-FIRED HIGH EFFICIENCY DOWNFLOW CONDENSING MODELS



DESCRIPTION

These Category IV, highly efficient, compact, sealed combustion, condensing type furnaces are designed for residential and commercial installations where the ambient temperature is above 32°F, or higher. All use outdoor combustion air. They may be either side wall or through-roof vented using approved plastic type combustion air and vent piping. A Vent Termination Kit is required. All units are factory assembled, wired and tested to assure dependable and economical installation and operation.

FEATURES

Features of the DGD Series gas furnaces include:

- Electronic hot surface ignition for fuel cost saving operation and increased dependability and reliability.
- Induced combustion system with inshot main burners for quiet, efficient operation. (Meets low NOx requirements.)
- AGA/CGA approved for field application in manufactured/mobile homes.
- 100% shut-off main gas valve for extra safety. Propane convertible.
- PSC – multiple-speed direct drive motor with large, quiet blower.
- 24V, 40 VA control transformer and cooling relay supplied for add-on cooling.
- Hi-tech sectionalized primary heat exchanger of aluminumized steel.
- Streamlined secondary (condensing) heat exchanger of high-grade stainless steel.
- Lifetime limited warranty on both heat exchangers.
- Sealed combustion design uses outdoor air to reduce internal heat load and drafts along with reduced potential for corrosion caused by contaminated indoor combustion air.
- Timed on, adjustable off blower capability.
- Blower door safety switch and combustion air safety.
- Attractively styled with baked-enamel finish.
- Easy access from front of unit for cleaning, maintenance or service.
- Cleanable, high efficiency filters supplied with furnaces.
- Electronic air cleaner and humidifier terminals.

RATINGS AND PHYSICAL DATA

MODEL NUMBER	HTG. CAP. INPUT MBH	SS OUTPUT MBH	AFUE* %	AIR TEMP. RISE °F	CFM @ MEAN AIR TEMP. RISE	MAX OUTLET AIR TEMP. °F	BLOWER			TOTAL UNIT AMPS
							DIA.	WIDTH	HP	
DGD06010U	60	55	92	45-75	586	175	10	6	1/2	9.1
DGD08012U	80	75	92	45-75	880	175	11	8	1/2	11.6
DGD10016U	100	95	92	45-75	1257	175	10	10	1	15.5
DGD12020U	120	112	92	45-75	2000	175	11	10	1	15.5

*AFUE ratings determined in accordance with DOE test procedures.
 Notes: 1. For altitudes above 2000 ft. reduce capacity 4% for each 1000 ft above sea level.
 2. Continuous return air temperature must not be below 55°F.

MODEL NUMBER	FILTER SIZE	ADD-ON COOLING		APPROXIMATE OPER. WEIGHT
		TONS	CFM* @ .5 ESP	
DGD06010U	14 X 20 (2)	2, 2-1/2	1050	175
DGD08012U	14 X 20 (2)	2-1/2, 3	1183	190
DGD10016U	14 X 20 (2)	3, 3-1/2, 4	1605	220
DGD12020U	14 X 20 (2)	3-1/2, 4, 5	1939	235

* ESP (External Static Pressure) .5" WC is at furnace outlet ahead of cooling coil.
 Note: All filters supplied with furnace are of high velocity cleanable type.

FIELD WIRING DIAGRAM

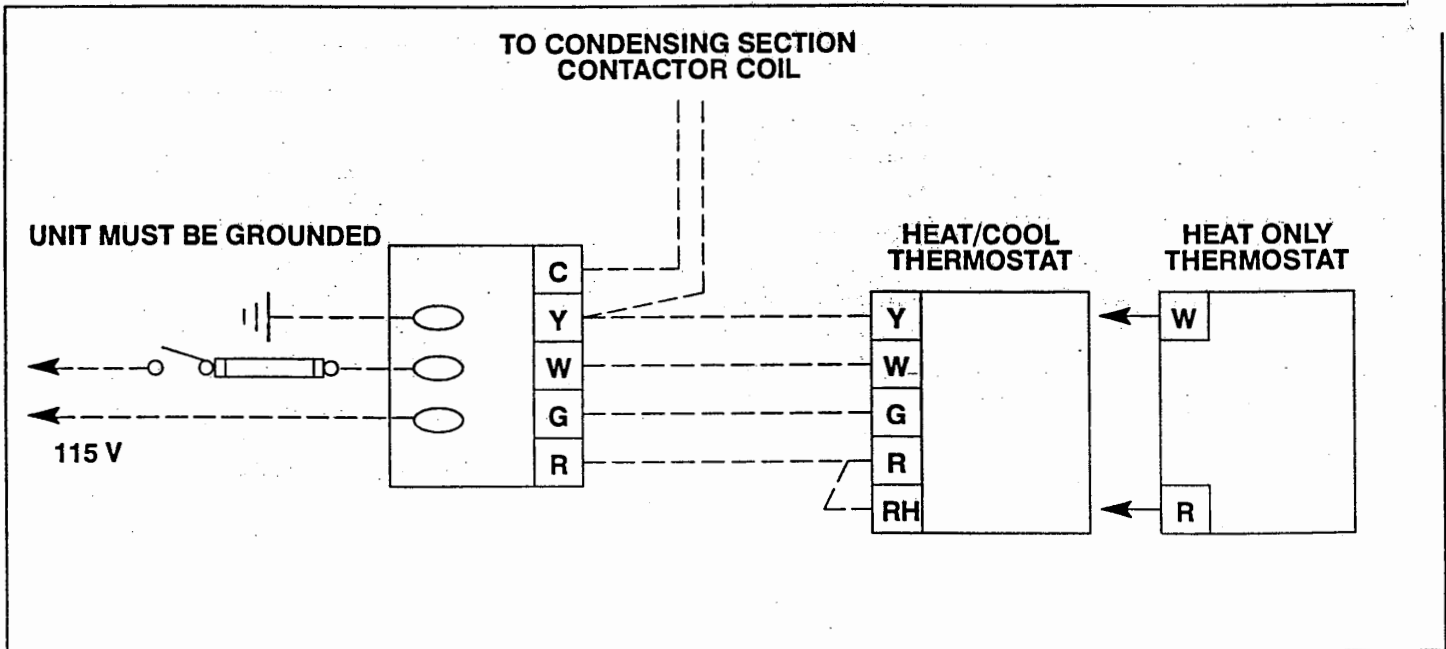

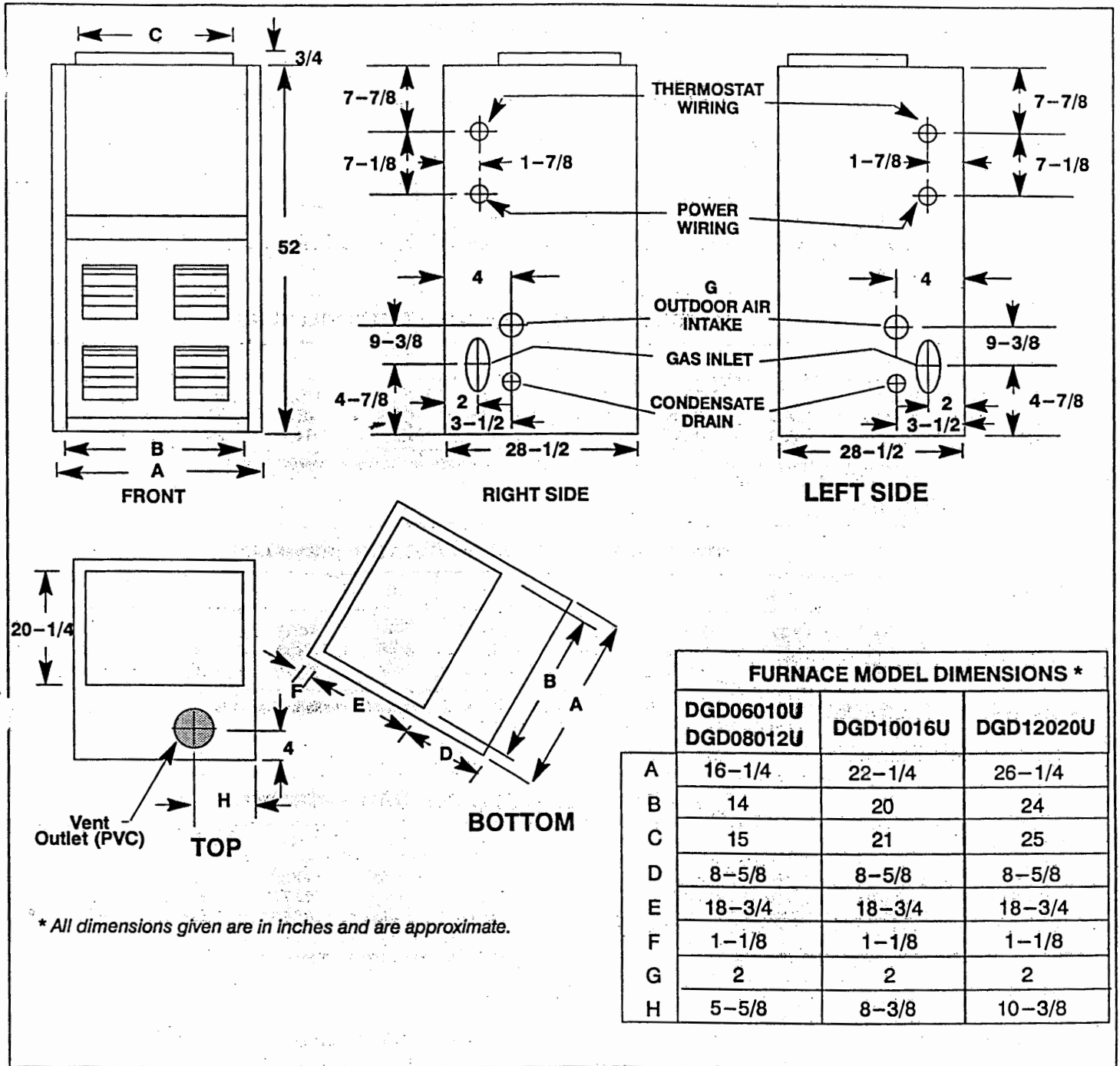

VENT SIZING TABLE

MODEL	PIPE SIZE	MAX. ELBOWS PER RUN						
		0-5 Feet	5-10 Feet	10-15 Feet	15-20 Feet	20-25 Feet	25-30 Feet	30-35 Feet
DGD06010U	1-1/2"	3	2	Note 1	Note 1	Note 1	Note 1	Note 1
	2"	5	5	5	5	5	5	5
DGD08012U	1-1/2"	3	2	Note 1	Note 1	Note 1	Note 1	Note 1
	2"	5	5	5	5	5	5	5
DGD10016U	3"	5	4	5	5	5	5	5
DGD12020U	3"	5	5	5	5	5	5	5

Notes: 1) Must use the larger pipe size indicated. 2) Long radius elbows recommended on these units.

BLOWER PERFORMANCE

Furnace # DGD06010U

STANDARD CFM AT EXTERNAL STATIC PRESSURE										
Blower Speed	.1	.2	.3	.4	.5	.6	.7	.8	.9	1
High	1276	1206	1154	1110	1049	998	916	835	746	642
Medium	1128	1098	1067	1020	960	903	829	764	695	572
Low	992	975	962	939	896	860	798	732	656	524

Airflow is expressed in standard cubic feet per minute. Notes: 1) Air filter is installed; and 2) motor voltage is at 115V.

Furnace # DGD08012U

STANDARD CFM AT EXTERNAL STATIC PRESSURE										
Blower Speed	.1	.2	.3	.4	.5	.6	.7	.8	.9	1
High	1389	1331	1296	1243	1183	1099	1020	947	851	747
Medium	1349	1305	1236	1181	1113	1059	988	894	811	714
Low	1250	1198	1164	1103	1041	982	916	841	771	681

Airflow is expressed in standard cubic feet per minute. Notes: 1) Air filter is installed; and 2) motor voltage is at 115V.

Furnace # DGD10016U

STANDARD CFM AT EXTERNAL STATIC PRESSURE										
Blower Speed	.1	.2	.3	.4	.5	.6	.7	.8	.9	1
High	1851	1797	1733	1671	1606	1534	1455	1375	1290	1204
Medium	1667	1620	1569	1520	1461	1408	1339	1252	1189	1089
Low	1424	1408	1378	1344	1300	1267	1219	1140	1070	977

Airflow is expressed in standard cubic feet per minute. Notes: 1) Air filter is installed; and 2) motor voltage is at 115V.

Furnace # DGD12020U

STANDARD CFM AT EXTERNAL STATIC PRESSURE										
Blower Speed	.1	.2	.3	.4	.5	.6	.7	.8	.9	1
High	2242	2169	2083	1997	1939	1857	1749	1680	1610	1518
Medium	1728	1703	1688	1658	1615	1552	1477	1411	1350	1268
Low	---	1356	1350	1328	1307	1295	1256	1198	1141	1063

Airflow is expressed in standard cubic feet per minute. Notes: 1) Air filter is installed; and 2) motor voltage is at 115V.

ACCESSORIES

Vent Terminal Kits

A vent terminal kit is required for all installations. Select the correct termination for your application:

- 1VK0307 – 2" pipe size for vertical roof applications
- 1VK0308 – 3" pipe size for vertical roof applications
- 1VK0311 – 2" pipe size for horizontal sidewall applications
- 1VK0312 – 3" pipe size for horizontal sidewall applications

Propane (LP) Conversion Kit – 1NP0355

This accessory conversion kit may be used to convert natural gas units for propane (LP) operation.

Combustible Floor Bases:

- 1FB0302 is used with 16-1/4" wide units
- 1FB0303 is used with 22-1/4" wide units
- 1FB0304 is used with 26-1/4" wide units.

Condensate Pump – 2CP03700101

Neutralizer Kit – 1NK0301

Evcon Industries, Inc.

3110 North Mead
P.O. Box 19014
Wichita, KS 67204-9014