

DG U Series

650.75-N2E (995)  
035-13500

# INSTALLATION INSTRUCTION

**GAS-FIRED FURNACES - HIGH-EFFICIENCY  
UPFLOW CONDENSING MODELS — 40 - 120 INPUT**

**NOTICE TO OWNER / USER - THIS BOOKLET CONTAINS THE  
INSTALLATION INSTRUCTIONS AND OTHER RELATED INFORMA-  
TION FOR YOUR FURNACE. IT SHOULD BE RETAINED FOR  
FUTURE REFERENCE**



## FOR YOUR SAFETY

### WHAT TO DO IF YOU SMELL GAS

- Do not try to light any appliance.
- Open windows.
- Do not touch any electrical switch; do not use any phone in your building.
- Extinguish any open flames.
- Immediately call your gas supplier from a neighbor's phone. Follow the gas supplier's instructions.
- If you cannot reach your gas supplier, call the fire department.

## FOR YOUR SAFETY

Do not store or use gasoline or other flammable vapors and liquids in the vicinity of this or any other appliance.

**WARNING: Improper installation, adjustment, alteration, service or maintenance can cause injury or property damage. Refer to this manual. For assistance or additional information, consult a qualified installer, service agency or the gas supplier.**



## TABLE OF CONTENTS

### GENERAL INFORMATION

Description .....	2
Inspection .....	2
Notes, Cautions, & Warnings .....	2
Vent Safety Check Procedure .....	2-3

### SPECIFIC UNIT INFORMATION

Nomenclature .....	3
Limitations & Location .....	3
Clearances .....	3 & 5
Dimensions .....	4
Ratings & Physical Data .....	4
Unit Wiring Diagram .....	18

### UNIT INSTALLATION

Ductwork .....	5-6
Filters .....	6
Gas Piping .....	6-7
Electrical Power/Control Connection .....	7
Combustion Air & Vent System .....	8-10
Condensate Piping .....	10

Safety Controls .....	11
Start-Up & Adjustments .....	11-12
Ignition System Sequence .....	12
Checking Gas Input .....	12 & 13
Adjustment of Manifold Gas Pressure .....	13
Adjustment of Temperature Rise .....	13
Adjustment of Fan Control Settings .....	14
Accessory Connections .....	14

### OPERATION & MAINTENANCE

Sequence of Operation .....	14-15
Maintenance .....	15
Air Filters .....	15
Blowers .....	15-16
Burners .....	16
Lubrication .....	15
Cleaning Heat Exchangers .....	16
Troubleshooting .....	16
Furnace Control Diagnostics .....	17
Airflow Data .....	19

## GENERAL INFORMATION

### DESCRIPTION

This Category IV, sealed combustion furnace is designed for residential installation in a basement, closet, recreation room, garage or other location provided space temperature is 32°F or higher.

### INSPECTION

As soon as a unit is received, it should be inspected for possible damage during transit. If damage is evident, the extent of the damage should be noted on the carrier's freight bill. A separate request for inspection by the carrier's agent should be made in writing. Also, before installation the unit should be checked for screws or bolts which may have loosened in transit. There are no shipping or spacer brackets which need to be removed.

### NOTES, CAUTIONS, & WARNINGS

The installer should pay particular attention to the words:

**NOTE, CAUTION and WARNING.** NOTES are intended to clarify or make the installation easier. CAUTIONS are given to prevent equipment damage. WARNINGS are given to alert the installer that personal injury and/or equipment or property damage may occur if installation procedures are not handled properly.



**CAUTION:** The cooling coil must be installed in the supply air duct, downstream of the furnace. This is above the furnace on an upflow application.

The furnace room must not be used as a broom closet or for any other storage purposes as a fire hazard may be created. Never store items such as the following on, near, or in contact with the furnace.

1. Spray or aerosol cans, rags, brooms, dust mops, vacuum cleaners or other cleaning tools.

2. Soap powders, bleaches, waxes or other cleaning compounds; plastic items or containers; gasoline, kerosene, cigarette lighter fluid; dry-cleaning fluids or other volatile fluid.
3. Paint thinners and other painting compounds.
4. Paper bags or other paper products.



**WARNING:** Never operate the furnace with the blower door removed. To do so could result in serious personal injury and/or equipment damage.



**WARNING:** This furnace may not be common vented with any other appliance, since it requires separate, properly-sized air intake and vent lines. The furnace shall not be connected to any type of B, BW or L vent or vent connector, and not connected to any portion of a factory-built or masonry chimney.

### VENT SAFETY CHECK PROCEDURE

If this furnace is replacing a common-vented furnace, it may be necessary to resize the existing vent line and chimney to prevent oversizing problems for the new combination of units. Refer to the National Gas Code (ANSI Z223.1-) or CANI-B149.1 or .2 Installation Code (latest editions).

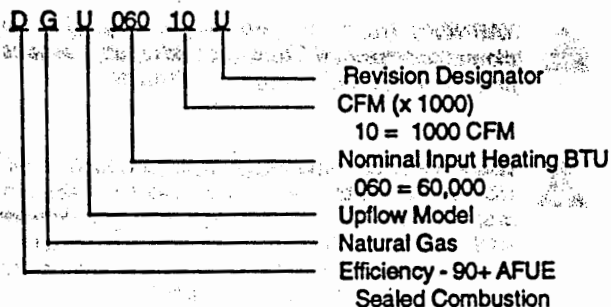
The following steps shall be followed with each appliance connected to the venting system placed in operation, while any other appliances connected to the venting system are not in operation:

1. Seal any unused openings in the venting system.
2. Inspect the venting system for proper size and horizontal pitch, as required in the National Fuel Gas Code, ANSI Z223.1, or the CAN/CGA B149 Installation Codes and these instructions. Determine that there is no blockage or restriction, leakage, corrosion or other deficiencies which could cause an unsafe condition.

3. Insofar as is practical, close all building doors and windows and all doors between the space in which the appliance(s) connected to the venting system are located and other spaces of the building. Turn on clothes dryers and any appliance not connected to the venting system. Turn on any exhaust fans, such as range hoods and bathroom exhausts, so they shall operate at maximum speed. Do not operate a summer exhaust fan. Close fireplace dampers.
4. Follow the lighting instructions. Place the appliance being inspected in operation. Adjust thermostat so the appliance shall operate continuously.
5. Test for draft hood equipped appliance spillage at the draft hood relief opening after 5 minutes of main burner operation. Use the flame of a match or candle.
6. After it has been determined that each appliance connected to the venting system properly vents when tested as outlined above, return doors, windows, exhaust fans, fireplace dampers and any other gas burning appliance to their previous conditions of use.
7. If improper venting is observed during any of the above tests, the venting system must be corrected.
8. Any corrections to the common venting system must be in accordance with the National Fuel Gas Code Z223.1 or CAN1-B149.1 or .2 Installation Code (latest editions). If the common vent system must be resized, it should be resized to approach the minimum size as determined using the appropriate tables in Appendix G of the above codes.

## SPECIFIC UNIT INFORMATION

### NOMENCLATURE



## LIMITATIONS & LOCATION

This furnace should be installed in accordance with all national and local building/safety codes and requirements, or in the absence of local codes, with the National Fuel Gas Code ANSI Z223.1 or CAN1-B149.1 or .2 Installation Code (latest editions), local plumbing or waste water codes, and other applicable codes.

## CLEARANCES FOR ACCESS

Ample clearances should be provided to permit easy access to the unit. The following minimum clearances are recommended:

1. Twenty-four (24) inches between the front of the furnace and an adjacent wall or another appliance, when access is required for servicing and cleaning.

2. Eighteen (18) inches at the side where access is required for passage to the front when servicing or for inspection or replacement of flue/vent connections.

**NOTE:** In all cases, accessibility clearances shall take precedence over clearances for combustible materials where accessibility clearances are greater.



**CAUTION:** Do not install the furnace in an unconditioned space or garage that could experience ambient temperatures of 32°F (0°C) or lower.



**CAUTION:** The furnace is not to be used for temporary heating of buildings or structures under construction.



**CAUTION:** This unit must be installed in a level (1/4") position side-to-side and front-to-back to provide proper condensate drainage.



**CAUTION:** Do not allow return air temperature to be below 55°F for extended periods. To do so may cause condensate to occur in the main fired heat exchanger.



**WARNING:** Furnaces shall not be installed directly on carpeting, tile or other combustible material other than wood flooring.



**WARNING:** Furnace shall be installed so the electrical components are protected from water.

The size of the unit should be based on an acceptable heat loss calculation for the structure.

Check the rating plate to make certain the unit is equipped for the type of gas supplied, and proper electrical characteristics are available.

For installations above 2,000 feet, reduce input 4% for each 1,000 feet above sea level.



**WARNING:** Do not install this unit in a mobile home.

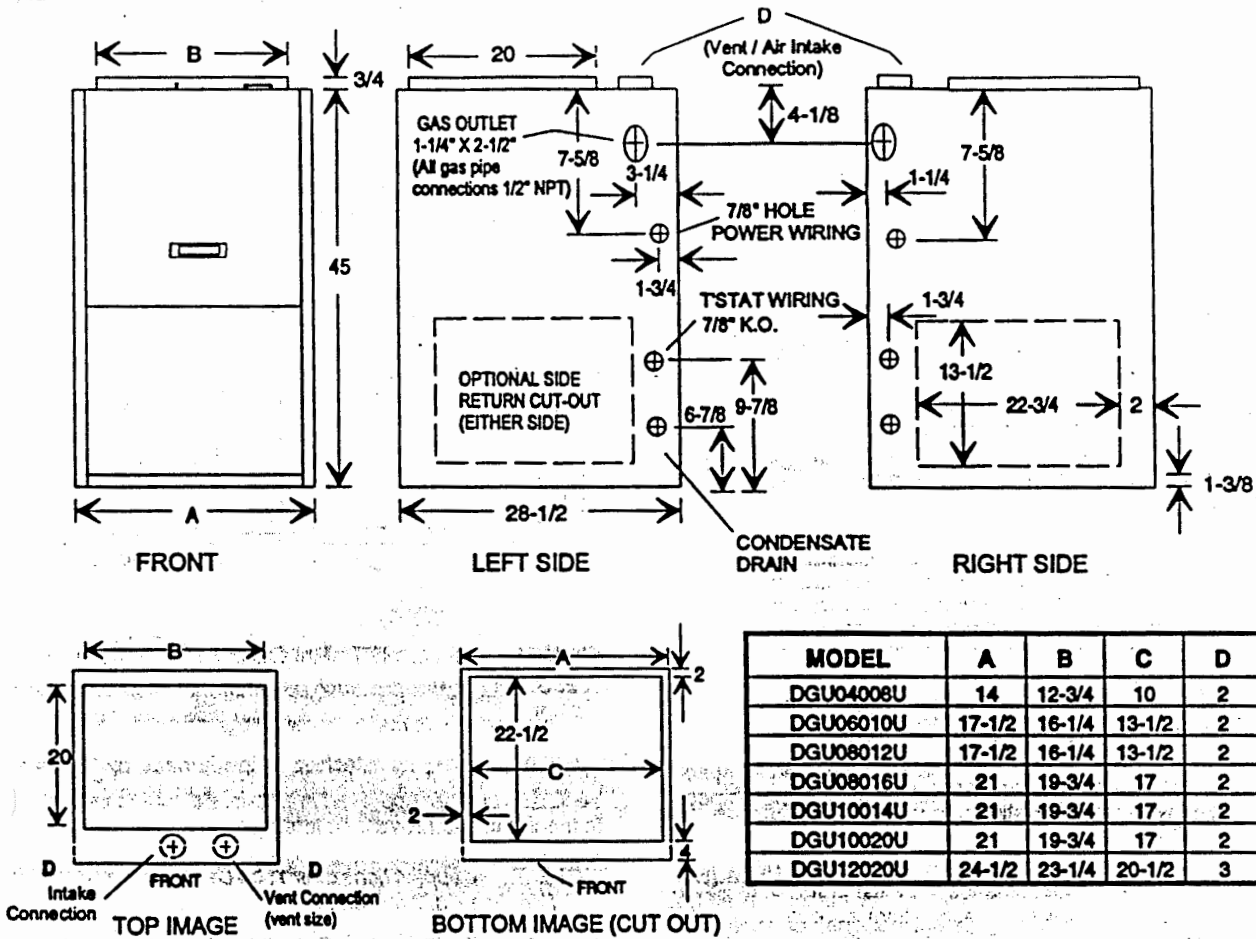
A furnace installed in a residential garage shall be located so that all burners and burner ignition devices are located not less than 18" above the garage floor, and located or protected to prevent damage by vehicles.

Allow clearances from combustible materials as listed under "Clearances to Combustibles", ensuring that service access is allowed for both the burners and blower.

When the furnace is used in conjunction with a cooling coil, the furnace must be installed parallel with or on the upstream side of the cooling unit to avoid condensation in the primary heat exchanger.

When a parallel flow arrangement is used, the dampers or other means used to control air flow shall be adequate to prevent chilled air from entering the furnace, and if manually operated, must be equipped with means to prevent operation of either unit unless the damper is in the full heat or cool position.

**DIMENSIONS**



MODEL	A	B	C	D
DGU04008U	14	12-3/4	10	2
DGU06010U	17-1/2	16-1/4	13-1/2	2
DGU08012U	17-1/2	16-1/4	13-1/2	2
DGU08016U	21	19-3/4	17	2
DGU10014U	21	19-3/4	17	2
DGU10020U	21	19-3/4	17	2
DGU12020U	24-1/2	23-1/4	20-1/2	3

All dimensions are in inches, and are approximate.

**TABLE 1 - RATINGS & PHYSICAL DATA**

MODEL	HTG. CAP. INPUT MBH	SS OUTPUT MBH	AFUE	AIR TEMP. RISE °F	CFM @ MEAN AIR TEMP. RISE	MAX. OUTLET AIR TEMP. °F	BLOWER			TOTAL UNIT AMPS	MAX.* OVER-CURRENT PROT.	MIN.* WIRE (AWG) @ 75'
							DIA.	WIDTH	HP			
DGU04008U	40	37	91.5	35 - 65	685	165	9	6	1/4	9.0	20	14
DGU06010U	60	54	91.5	45 - 75	850	175	10	6	1/3	9.0	20	14
DGU08012U	80	73	91.5	35 - 65	1160	165	11	8	1/2	9.0	20	14
DGU08016U	80	75	91.5	30 - 60	1450	160	11	8	3/4	12.0	20	14
DGU10014U	100	93	91.5	45 - 75	1465	175	10	10	1/2	9.0	20	14
DGU10020U	100	93	91.5	30 - 60	1955	160	10	10	1	12.0	20	14
DGU12020U	120	111	91.5	45 - 75	1730	175	11	10	1	12.0	20	14

\* Wire size and overcurrent protection must comply with National Electric Code  
 NOTES: 1. For altitudes above 2000 ft. reduce capacity 4% for each 1000 ft. above sea level.  
 2. Wire size based on copper conductors, 60°C, 3% voltage drop.  
 3. Continuous return air temperature must not be below 55°F.

The furnace shall be located:

1. Where a minimum amount of air intake/vent piping and elbows will be required.
2. As centralized with the air distribution as possible.
3. In an area where ventilation facilities provide for safe limits of ambient temperature under normal operating conditions. Ambient temperatures must not fall below 32°F (0° C).
4. Where it will not interfere with proper air circulation in the confined space.
5. Where the outdoor combustion air/vent terminal will not be blocked or restricted.
6. Where it will not interfere with the cleaning, servicing or removal of other appliances.

**CLEARANCES TO COMBUSTIBLES**

Minimum clearances from combustible construction are in inches:

Top .....	1
Front .....	3
Vent Piping .....	0
Rear .....	0
Sides .....	0

**DUCTWORK**

The duct system's design and installation must:

1. Handle an air volume appropriate for the served space and within the operating parameters of the furnace specifications.
2. Be installed in accordance with standards of NFPA (National Fire Protection Association) as outlined in NFPA pamphlets 90A and 90B (latest editions) or applicable national, provincial, local fire and safety codes.
3. Create a closed duct system. The supply duct system must be connected to the furnace outlet and the return duct system must be connected to the furnace inlet. Both supply and return duct systems must terminate outside the space containing the furnace.
4. Generally complete a path for heated or cooled air to circulate through the air conditioning and heating equipment and to and from the conditioned space.

**SUPPLY PLENUM CONNECTION**

Attach the supply plenum to the furnace outlet duct connection flanges. This is typically through the use of "S" cleat material when a metal plenum is used. The use of an approved flexible duct connector is recommended on all installations. This connection should be sealed to prevent air leakage.

If a matching cooling coil is used, it may be placed directly on the furnace outlet and sealed to prevent leakage. Follow the coil instructions for installing the supply plenum.

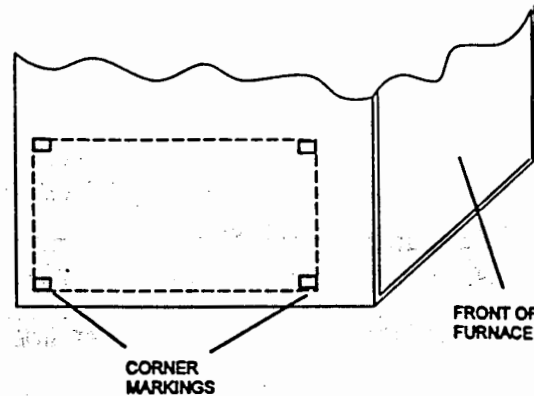
On all installations a removable access panel should be provided in the outlet duct such that smoke or reflected light would be observable inside the casing to indicate the presence of leaks in the heat exchanger. This access cover shall be attached in such a manner as to prevent leaks.

**RETURN DUCT CONNECTION**

Return air may enter the furnace through the side(s) or bottom depending on the type of application. See the specific type application installation for details. Be sure to see the "Filters" section of this instruction.

**SIDE RETURN**

Locate and remove the four square corner locating knockouts. These indicate the size of the cutout to be made in the furnace side panel. Refer to Figure 1.



**FIGURE 1 - SIDE RETURN CUTOUT MARKINGS**

*NOTE: Some accessories such as electronic air cleaners and pleated media may require a larger side opening.*

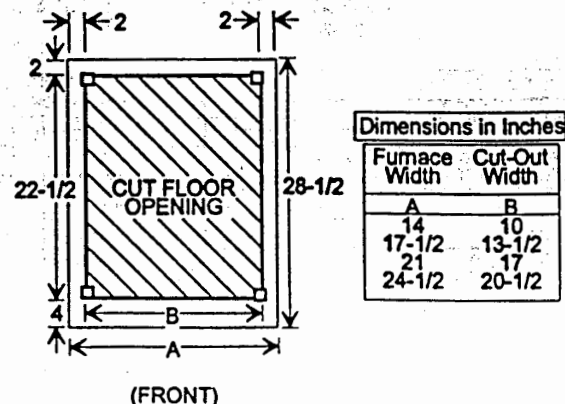
The return duct may be attached to the furnace by "S" cleat bend tabs or other approved methods. Be sure to seal the duct to the furnace to prevent air leakage.

*NOTE: Those applications over 1800 CFM require either return from two sides, or bottom.*

Where the return duct system is not complete, the return connection must run full size to a location outside the utility room or basement. For further details, consult Section 5.3 (air for Combustion and Ventilation) of the National Fuel Gas Code, ANSI Z223.1, or CAN/CGA B149.1 or .2, Installation Code - latest editions.

**BOTTOM RETURN**

To convert the furnace to open bottom return, locate and remove the four square corner locating knockouts. These indicate the size of the cutout to be made in the bottom panel. Refer to Figure 2.



**(FRONT)**  
**FIGURE 2 - BOTTOM RETURN (COMBUSTIBLE FLOOR)**

Bottom return applications normally pull return air through a base platform or return air plenum. Refer to Figure 2 for opening dimensions. Be sure the return platform structure is suitable to support the weight of the furnace. Seal the furnace to the plenum to prevent air leakage.

**NOTE:** If an external mounted filter rack is being used, see the instructions provided with that accessory for proper hole cut size.

Upflow attic installations must meet minimum clearances to combustibles and have floor support with required service accessibility.

**FILTERS**

MODEL	FILTER SIZE	
	SIDE	BOTTOM
DGU04008U	16 x 25	14 x 25
DGU06010U	16 x 25	16 x 25
DGU08012U	16 x 25	16 x 25
DGU08016U	16 x 25	20 x 25
DGU10014U	16 x 25	20 x 25
DGU10020U	(2) 16 x 25	20 x 25
DGU12020U	(2) 16 x 25	20 x 25

**CAUTION:** All installations must have a filter installed.

An internal mount, high velocity, cleanable filter is provided along with mounting hardware. It may be installed on the left side, right side, or bottom location depending on your application. After determining the best return air location, install the two clips for the filter retainer wire.

There are slotted holes in the rear of the cabinet to accept the clips for all applications. Insert the clips from the outside of the cabinet. Place the ends of the wire filter retainer into the clips from the inside of the blower compartment.

**NOTE:** The clips must be installed in the rear of the furnace before rear access is restricted.

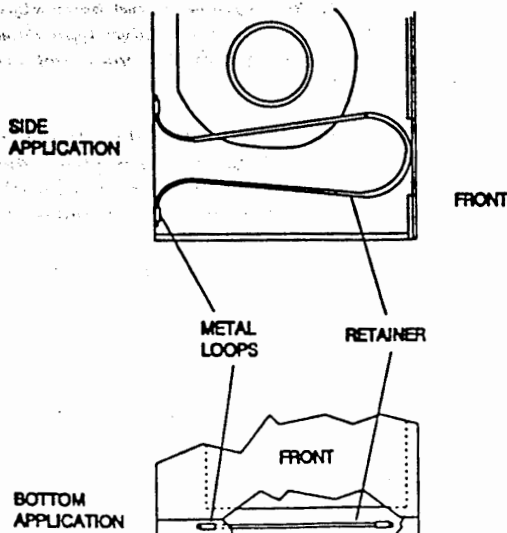


FIGURE 3 - FILTER RETAINER

Place the filter into the blower compartment and slip the wire retainer under the front cabinet flange to hold the filter in place. Refer to Figure 3. It may be necessary to trim the filter to the proper size.

**GAS PIPING**

The gas supply must be installed in accordance with the current National Fuel Gas Code, ANSI Z223.1 (in the U.S.) or CAN-B149.1 or .2 (in Canada) installation codes and all applicable local and utility requirements. All pipe and fitting material, pipe size and installation procedures must comply with the appropriate code. Some utilities may require larger pipe sizes than shown in the code.

Gas piping may be connected from either side of the furnace. For piping through the right side panel, use a 90 degree service ell or 1-1/2" long nipple and standard 90 elbow in the gas valve. For piping through the left side panel, two 90 degree elbows are required for intake pipe clearance.

The installation of a ground joint union and drip leg are required. Refer to Figure 4. Maximum and minimum supply gas pressures are shown below.

INLET GAS PRESSURE	
Natural Gas	
Minimum	4.5 in. W.C
Maximum	10.5 in. W.C.

**NOTE:** An accessible manual shutoff valve must be installed upstream of the furnace gas controls and within 6 feet of the furnace. A 1/8" NPT plugged tapping, accessible for test gauge connection must be installed immediately upstream of the gas supply connection to the furnace.

The furnace must be isolated from the gas supply piping system by closing its individual external manual shutoff valve during any pressure testing of the gas supply piping system at pressures equal to or less than 1/2 psig (3.48 kPa).

The furnace and its individual shutoff valve must be disconnected from the gas supply piping system during any pressure testing of that system at test pressures in excess of 1/2 psig (3.48 kPa).

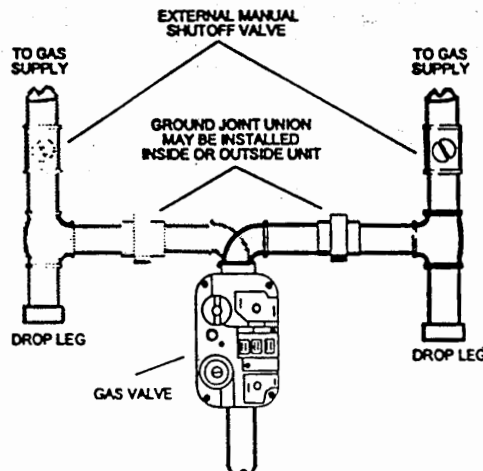


FIGURE 4 - GAS PIPING

**WARNING:** Compounds used on threaded joints of gas piping must be resistant to the action of liquefied petroleum gases. After connections are made, leak-test all pipe connections.

**WARNING:** After all gas piping connections are completed, leak test all joints, fittings and furnace connections with rich soap and water solution, commercially available bubble type leak detection fluid, or other approved means.

**WARNING:** Do not use an open flame or other source of ignition for leak testing.

**CAUTION:** Never apply a pipe wrench to the body of the combination automatic gas valve. A wrench must be placed on the projection or wrench boss of the valve when installing piping to it.

### ELECTRICAL POWER CONNECTION

Field wiring to the unit must conform to and be grounded in accordance with the provisions of the National Electrical Code ANSI/NFPA No. 70-latest edition, Canadian Electric Code C22.1 Part 1 - (latest edition) and/or local codes. Electric wires which are field installed shall conform with the temperature limitation for 63°F/35°C rise wire when installed in accordance with instructions. Specific electrical data is given for the furnace on its rating plate and in Table 1 of this instruction.

Provide a power supply separate from all other circuits. Install overcurrent protection and disconnect switch per local/national electrical codes. The switch should be close to the unit for convenience in servicing. With the disconnect switch in the OFF position, check all wiring against the unit wiring label. Also, see the wiring diagram in this instruction.

**WARNING:** Use copper conductors only.

**NOTE:** The furnace's control system depends on correct polarity of the power supply and a proper ground connection.

Connect the power supply as shown on the unit wiring label on the inside of the blower compartment door and Figures 5 & 6. The black furnace lead must be connected to the L1 (hot) wire from the power supply. The white furnace lead must be connected to neutral. Also, the green equipment ground wire must be connected to the power supply ground.

Remove the screws retaining the wiring box cover. Route the power wiring through the unit side panel with a conduit connector or other proper connection. Make wiring connections as shown in Figure 5. Replace the wiring box and screw.

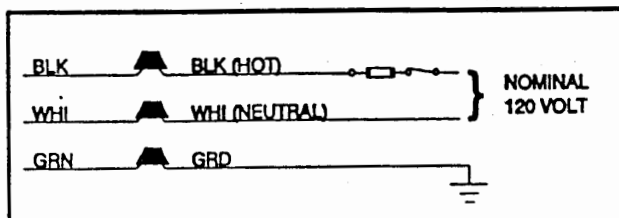


FIGURE 5 - POWER WIRING CONNECTIONS

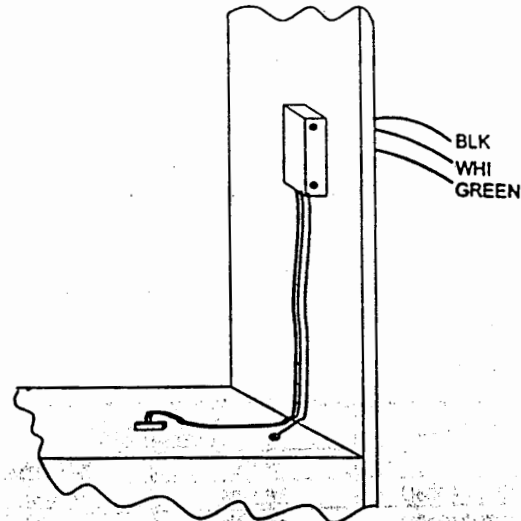


FIGURE 6 - POWER WIRING CONNECTION BOX

An alternate wiring method is to use a field provided 2 x 4 box and cover on the outside of the furnace. Route the furnace leads into the box using a protective bushing where the wires pass through the furnace panel.

**NOTE:** The power connection leads and wiring box on upflow units may be relocated to the left side of the furnace.

### ELECTRICAL CONTROL CONNECTIONS

Install the field-supplied thermostat. The thermostat instructions for wiring are packed with the thermostat. With the thermostat set in the OFF position and the main electrical source disconnected, complete the low-voltage wiring from the thermostat to the terminal board on the low voltage transformer. Connect Class 2 control wiring as shown in Figures 7 & 8.

**Set the heat anticipator in the room thermostat to 45 amps. Setting it lower will cause short cycles. Setting it higher will cause the room temperature to exceed the setpoints.**

**NOTE:** Some electronic thermostats do not have adjustable heat anticipators. They may have other type cycle rate adjustments. Follow the thermostat manufacturer's instructions.

The 24-volt, 40 VA transformer is sized for the furnace components only, and should not be connected to power auxiliary devices such as humidifiers, air cleaners, etc. The transformer may provide power for an air conditioning unit contactor.

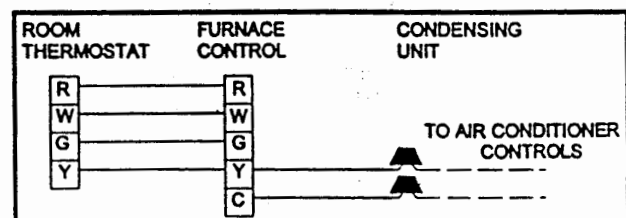


FIGURE 7 - TYPICAL HEATING AND COOLING



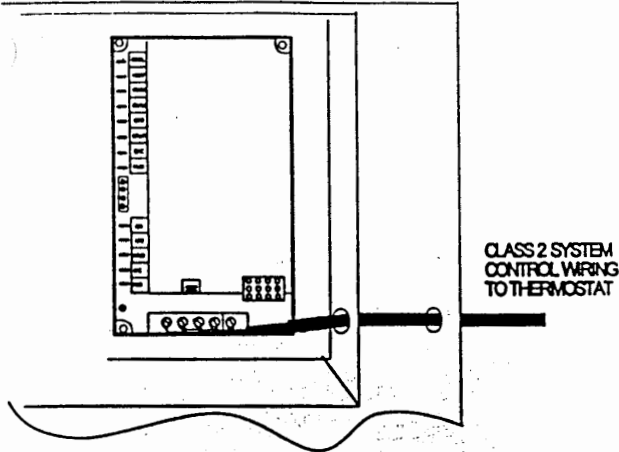


FIGURE 8 - CONTROL WIRING CONNECTIONS

**AIR AND VENT SYSTEM**

This furnace is certified to be installed with a 2-pipe sealed combustion intake/vent system. Be sure to follow the venting section details, related information and limitations for installation.

**TWO PIPE SEALED COMBUSTION AIR AND VENT SYSTEM**

This furnace requires outdoor combustion air. Two separate, properly-sized pipes must be used. One bringing outdoor air from the outdoors to the furnace combustion air intake on the top of the burner box, and a second pipe from the furnace vent connection (top right of unit) back to the outdoors.

The intake/vent should be located either through the wall (horizontal or side vent) or through the roof (vertical vent). Care should be taken to locate side vented systems where trees or shrubs will not block or restrict supply air from entering or combustion products from leaving the terminal.

Also, the terminal assembly should be located as far as possible from a swimming pool or a location where swimming pool chemicals might be stored. Be sure the terminal assembly follows the outdoor clearances listed in the following table for U.S. installations: In Canada, refer to CAN/CGA-B149.1 or 2 Installation Code (latest edition -Venting Systems and Air Supply).

TABLE 2 - INTAKE/VENT PIPING - 2 PIPE SYSTEM

Model	Pipe Size	Max. Elbows vs. One Way Vent Length (Ft.)			
		5-40	45	50	75
DGU04008U	2"	6	5	4	N/A
DGU06010U					
DGU08012U					
DGU08016U					
DGU10014U	3"	8	7	6	5
DGU10020U					
DGU12020U					

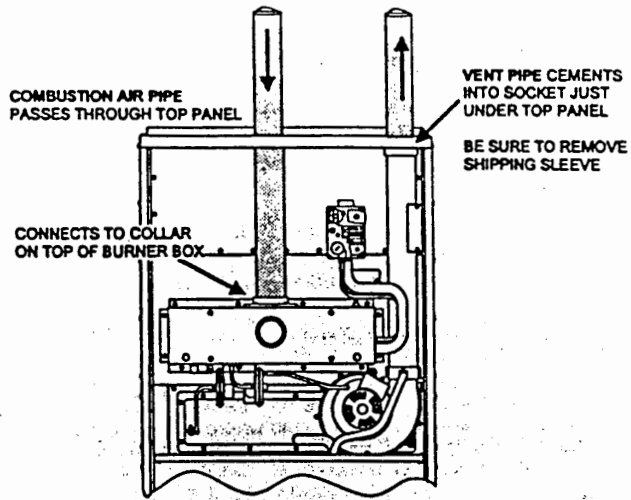


FIGURE 9 - AIR INTAKE/VENT LOCATIONS

**COMBUSTION AIR INTAKE/VENT CONNECTIONS**

*NOTE: Furnace combustion air and vent pipe connections are shown below. Any pipe size change must be made outside furnace casing in a vertical pipe section to allow proper drainage of vent condensate.*

Furnace Intake / Vent Connection Sizing		
	40 - 100 MBH	120 MBH
Intake	2"	3"
Vent	2"	2" (See Note)

*NOTE: Vent must be increased to 3" on this models. This change must be made in a vertical pipe as close to the furnace as possible*

**COMBUSTION AIR/VENT PIPE SIZING**

Refer to Table 2 to select the proper size piping for combustion air intake and venting. The size will be determined by a combination of furnace model, total length of run, and the number of elbows required. The following rules must also be observed.

1. Long radius elbows are required for all units.
2. Elbows are assumed to be 90 degrees. Two 45 degree elbows count as one 90 degree elbow.
3. Elbow count refers to combustion air piping and vent piping separately. For example, if the table allows for 5 elbows, this will allow a maximum of 5 elbows in the combustion air piping and a maximum of 5 elbows in the vent piping.
4. Three vent terminal elbows (two for vent pipe and one for air intake pipe) are already accounted for, and should not be counted in the allowable total indicated in the table. See section on vent terminal. These parts are shown shaded.
5. Combustion air and vent piping must be of the same diameter.
6. All piping and fittings are to be Schedule 40 PVC, meeting ASTM D1785 & D2466, or D2665, PVC primer per ASTM D2564 and PVC solvent cement per ASTM D2564 specifications.

### VENT TERMINATION

Side wall horizontal vent terminals and roof mounted vertical terminals may be field fabricated. Standard PVC/SRD fittings may be used. Terminal configuration must comply as detailed in this section.

**NOTE:** Combustion air and vent pipes must terminate together in the same atmospheric zone, either through a roof or sidewall.

**NOTE:** Accessory concentric intake/vent terminations are available for use with these furnaces. Refer to Form 650.75-N2.2V for installation instructions.

When selecting the location for combustion air/vent termination the following should be considered:

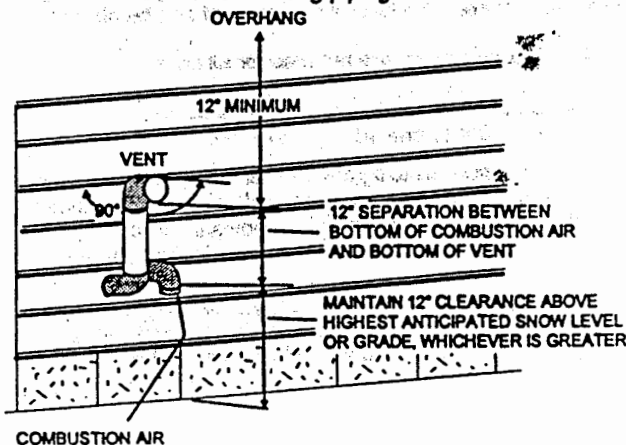
1. Comply with all clearance requirements as listed below.
2. Termination should be positioned where vent vapors will not damage plants or shrubs or air conditioning equipment.
3. Termination should be located where it will not be affected by wind gusts, light snow, airborne leaves or allow recirculation of flue gases.
4. Termination should be located where it will not be damaged or exposed to flying stones, balls, etc.
5. Termination should be positioned where vent vapors are not objectionable.

### VENT TERMINATION CLEARANCES (U.S. ONLY)

Dryer Vent .....	3 feet
Plumbing Vent Stack .....	3 feet
Gas Appliance Vent Terminal .....	1 foot
From any opening where vent gas could enter the building .....	1 foot
Above grade and anticipated snow depth .....	1 foot
Above grade when adjacent to a public walkway .....	7 feet
From electric, gas meters, regulators and relief equipment - min. horizontal distance .....	4 feet

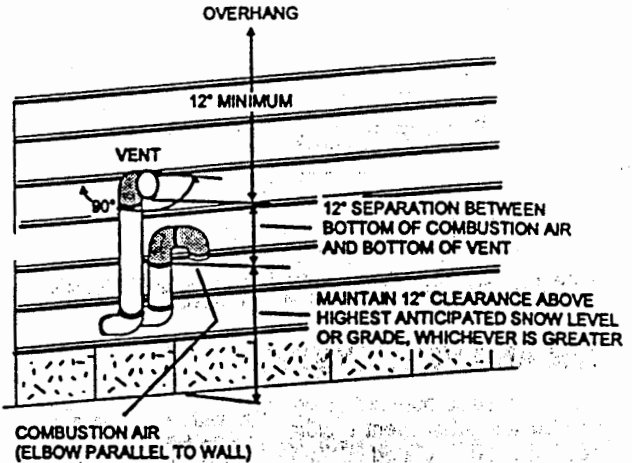
**NOTE:** Consideration must be given for degradation of building materials by flue gases.

**NOTE:** Shaded components of the combustion air/vent system shown in the following figures are considered to be part of the vent terminal. These components should not be counted when determining piping limitations. Roof termi-

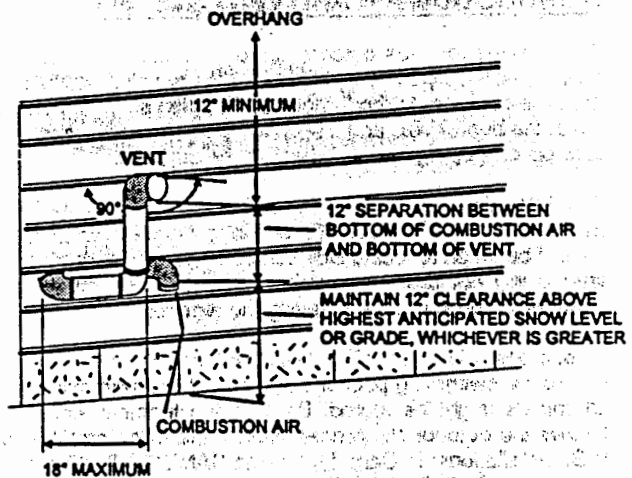


**FIGURE 10 - HORIZONTAL TERMINATION CONFIGURATION WITH 12" MINIMUM CLEARANCE**

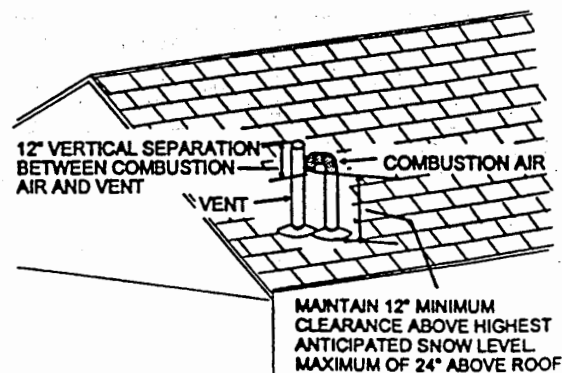
nation is preferred since it is less susceptible to damage, has reduced changes to intake connections and has less visible vent vapors. Refer to Figures 10 - 13. Sidewall termination may require sealing or shielding of building surfaces with a corrosive resistance material to protect against combustion product corrosion.



**FIGURE 11 - HORIZONTAL TERMINATION RAISED CONFIGURATION FOR ADDITIONAL CLEARANCE**



**FIGURE 12 - HORIZONTAL TERMINATION CONFIGURATION WITH HORIZONTAL EXTENSION**



**FIGURE 13 - VERTICAL TERMINATION**

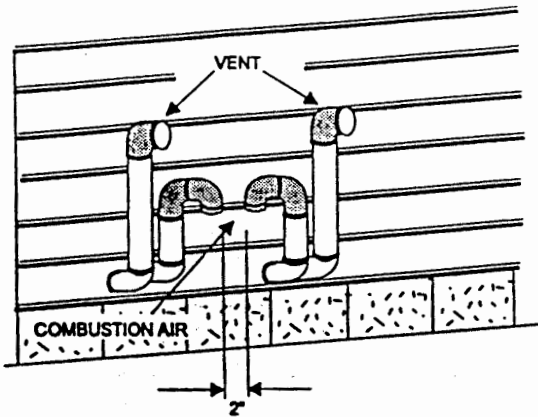


FIGURE 14 - DOUBLE SIDEWALL TERMINATION

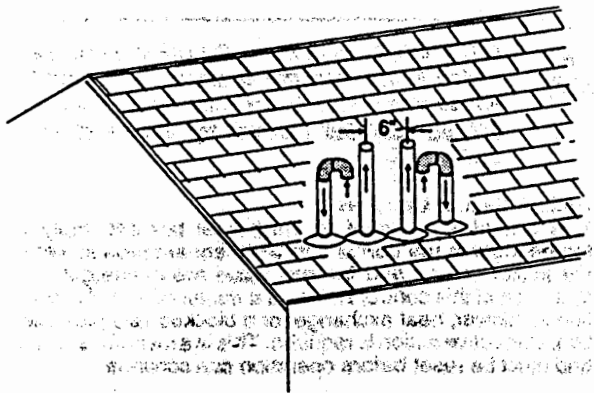


FIGURE 15 - DOUBLE ROOFTOP TERMINATION

### VENTING MULTIPLE UNITS

Each unit must have its own intake/vent piping and termination. Do not use common pipes for combustion air or venting. The vent terminals must be located as shown in Figures 14 & 15.

### PIPING ASSEMBLY

The final assembly procedure for the vent/combustion air piping is as follows:

1. Cut piping to the proper length, beginning at the furnace.
2. Deburr the piping inside and outside.
3. Chamfer the outer edges of the piping.
4. Dry-fit the entire vent/combustion air piping assembly.
5. Disassemble the piping and apply cement primer and cement per the cement manufacturer's instructions. Primer and cement must conform to ASTM D2564 for PVC, or ASTM D2235 for ABS piping.



**WARNING:** Solvent cements are flammable and must be used in well-ventilated areas only. Keep them away from heat, sparks and open flames (including pilots). Do not breathe vapors and avoid contact with skin and eyes.

6. All joints must be made to provide a permanent, air-tight, water-tight seal.

7. Support the combustion air and vent piping such that it is angled 1/4" per linear foot upward from the furnace. Piping should be supported with pipe hangers to prevent sagging. Maximum spacing between hangers is five (5) feet, except SDR-PVC piping, where maximum spacing is three (3) feet.
8. Seal around the openings where the combustion air and vent piping pass through the roof of side wall.



**CAUTION:** Vent piping must be insulated with 1/2" Armaflex insulation if it will be subjected to freezing temperatures such as routing through unheated areas or through an unused chimney.



**CAUTION:** When combustion air pipe is installed above a suspended ceiling, the pipe must be insulated with 1/2" Armaflex type insulation. The combustion air pipe should also be insulated when it passes through a warm, humid space.

### CONDENSATE PIPING

The condensate drain connection is shipped in the blower compartment. It consists of a formed hose with a 1/2" NPT male connection. A 1/2" FM x 3/4" PVC slip coupling is provided.

This drain hose may be installed to allow left or right side condensate drain connection. Refer to Figure 16. For left side drain connection the hose may be directly installed. For right side connection the hose must be shortened.

To install the drain hose assembly, remove the 7/8" knockout

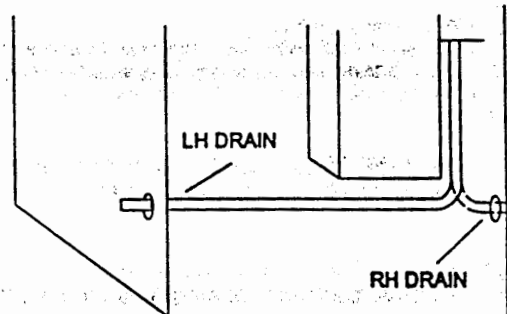


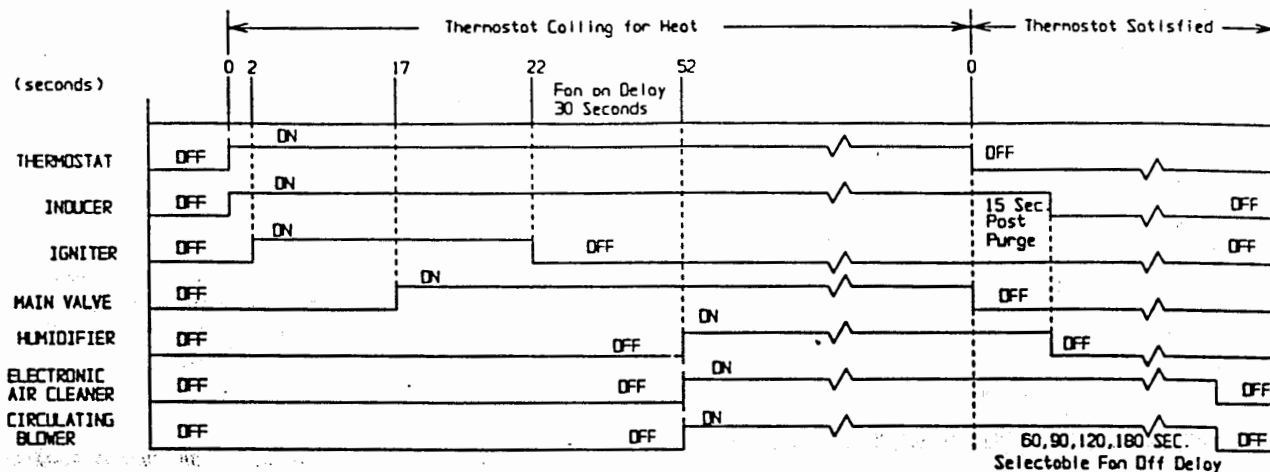
FIGURE 16 - CONDENSATE DRAIN CONNECTION

in the side panel. Remove the conduit nut from the 1/2" male fitting. Push the male fitting through the hole and reinstall the nut. The use of the 3/4" PVC coupling is optional.

The installation procedure for condensate piping is as follows:

#### Drain Connection

1. It is recommended that either 1/2" or 3/4" PVC or equivalent pipe be field installed as drain pipe. The condensate piping may be tied together with the air conditioning condensate drain if the air conditioning condensate drain line is trapped upstream of the tie-in and the combined drains are constructed of the same material.



### FURNACE CONTROL EVENT SCHEDULE

- All pipe joints must be cleaned, de-burred and cemented using PVC primer and cement.
- The furnace contains an internal trap. Therefore, no external trap should be used.
- If a condensate pump is used, it must be suitable for use with acidic water.
- Where required, a field-supplied neutralizer can be installed in the drain line, external to the furnace.

**NOTE:** The condensate drain from the furnace may be connected in common with the drain from an air conditioning coil if allowed by local code. Follow the instructions with the coil for trapping the drain.

### SAFETY CONTROLS

#### Blower Door Safety Switch

This unit is equipped with an Electrical Interlock Switch mounted in the blower compartment. This switch interrupts all power at the unit when the panel covering the blower compartment is removed.



**WARNING:** Blower and burner must never be operated without the blower panel in place.

Electrical supply to this unit is dependent upon the panel that covers the blower compartment being in place and properly positioned.

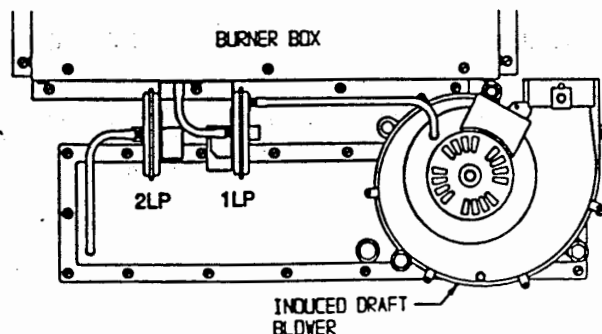


FIGURE 17 - PRESSURE SWITCH TUBING ROUTING



**CAUTION:** Main power to the unit must still be interrupted at the main power disconnect switch before any service or repair work is to be done to the unit. Do not rely upon the interlock switch as a main power disconnect.

#### Rollout Switch Controls

This control is mounted on the burner box assembly. If the temperature in the burner compartment exceeds its set point, the igniter control and the gas valve are deenergized. The operation of this control indicates a malfunction in the combustion air blower, heat exchanger or a blocked vent pipe connection. Corrective action is required. This is a manual reset control and must be reset before operation can continue.

#### Pressure Switches

This furnace is supplied with pressure switches which monitor the flow through the combustion air/vent piping system. These switches de-energize the ignition control module and the gas valve if any of the following conditions are present. Refer to Figure 17 for tubing connections

- Blockage of combustion air piping or terminal. (1LP)
- Blockage of vent piping or terminal. (1LP)
- Failure of combustion air blower motor. (1LP)
- Blockage of condensate drain piping (2LP).

#### Limit Control

There is a high temperature limit control located on the furnace vestibule panel near the gas valve. This is an automatic reset control and provides over temperature protection due to reduced airflow, such as a dirty filter.

### START-UP AND ADJUSTMENTS

The initial start-up of the furnace requires the following additional procedures:

- When the gas supply is initially connected to the furnace, the gas piping may be full of air. In order to purge this air, it is recommended that the ground union be loosened until the odor of gas is detected. When gas is detected, immediately retighten the union and check for leaks. Allow five minutes for any gas to dissipate before continuing with the start-up procedure.



**WARNING:** Be sure proper ventilation is available to dilute and carry away any vented gas.

2. The condensate trap must be filled with water before putting the furnace into operation. The recommended procedure is as follows:
  - a. Disconnect the condensate drain hose from the induced draft blower discharge.
  - b. Elevate this hose above trap level and fill with water using a funnel. Drain excess water into a container.
  - c. Replace the condensate drain hose and clamps.
3. All electrical connections made in the field and in the factory should be checked for proper tightness.

**IGNITION SYSTEM SEQUENCE**

1. Turn the gas supply ON at external valve and main gas valve.
2. Set the thermostat above room temperature to call for heat.
3. System start-up will occur as follows:
  - a. The induced draft blower motor will start and come up to speed. Shortly after venter start-up, the hot surface igniter will glow for about 17 seconds.
  - b. The ignition module will energize (open) the main gas valve for seven seconds.
  - c. After flame is established, the supply air blower will start in about 30 seconds.

**NOTE:** Burner ignition may not be satisfactory on first start-up due to residual air in line.

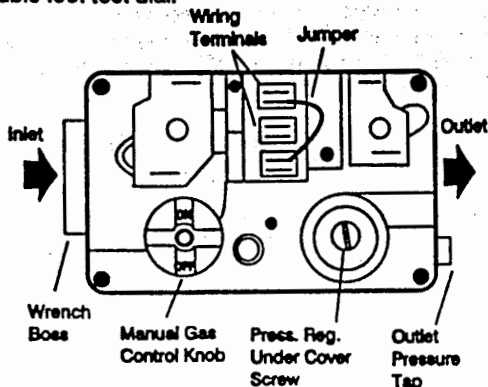
4. With furnace in operation, paint the pipe joints and valve gasket lines with a rich soap and water solution. Bubbles indicate a gas leak. Take appropriate steps to stop the leak. If the leak persists, replace the component.

**WARNING:** DO NOT omit this test! Never use a flame to check for gas leaks.

**CHECKING GAS INPUT (NATURAL GAS)**

**NOTE:** Front door of burner box must be secured when checking gas input.

1. Turn off all other gas appliances connected to the gas meter.
2. With the furnace turned on, measure the time needed for one revolution of the hand on the smallest dial on the meter. A typical domestic gas meter usually has a 1/2 or 1 cubic foot test dial.



**FIGURE 18 - GAS VALVE**

**TABLE 3 - GAS RATE (CUBIC FEET PER HOUR)**

Seconds for one Revol.	Size of Test Dial	
	1/2 cu. ft.	1 cu. ft.
10	180	360
12	150	300
14	129	257
16	113	225
18	100	200
20	90	180
22	82	164
24	75	150
26	69	138
28	64	129
30	60	120
32	56	113
34	53	106
36	50	100
38	47	95
40	45	90
42	43	86
44	41	82
46	39	78
48	37	75
50	36	72
52	35	69
54	34	67
56	32	64
58	31	62
60	30	60

3. Using the number of seconds for each revolution and the size of the test dial increment, find the cubic feet of gas consumed per hour from Table 3.

To find the BTUH input use the following formula:

$$\text{Cu. Ft. Gas} \times \text{meter correction factor} \times \text{Gas BTU Content} = \text{BTU Per Hour Input}$$

The gas meter is affected by both the temperature and also the barometric pressure. The meter should be correct at 60° F, and 30.0" barometric pressure. At all other conditions it will be inaccurate, although the correction factor is easily calculated. Higher temperatures (over 60° F) will speed up the meter and make it read high.

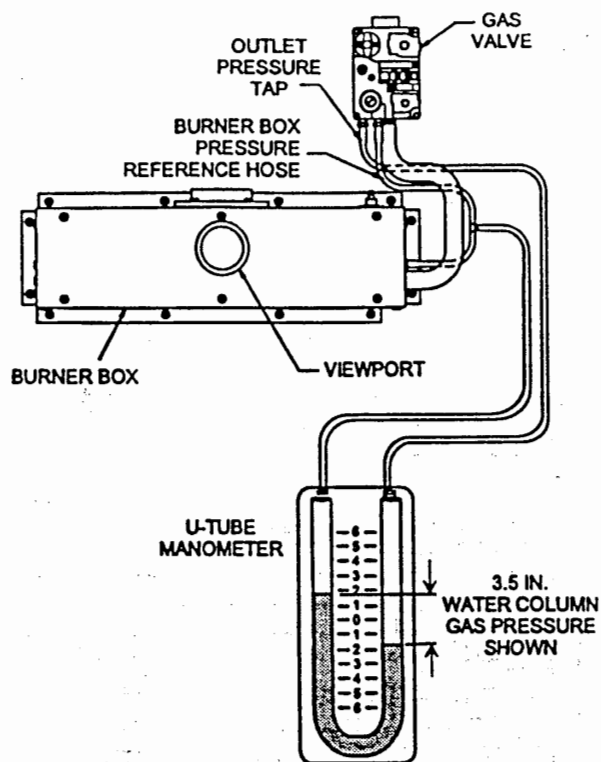
Temperatures under 60° F will slow it and make it read low. The barometric pressure above 30.0" will slow the meter and below 30.0" speed up the meter. At some conditions the meter may be off significantly, an error of ± 5% is not uncommon. The gas meter correction factor is calculated as follows:

$$\frac{(\text{Barometric Pressure}) \times 520}{(\text{Temperature} \text{ } ^\circ \text{F} + 460) \times 30} = \text{Meter Correction Factor}$$

Example 1: 28.9" Barometric Pressure, 80° F

$$\frac{(28.9) \times 520}{(80 + 460) \times 30} = \frac{15028}{16200} = .928 \text{ Correction Factor}$$

Contact your gas supplier for actual BTU content of the gas.



**FIGURE 19 - READING GAS PRESSURE**

**EXAMPLE - CHECKING GAS INPUT**

It is found by measurement that it takes 26 seconds for the hand on the 1 cubic foot dial to make a revolution with only a 120,000 Btuh furnace running. Using this information, locate 26 seconds in the first column of Table 3. Read across to the column headed "1 cubic foot" where you will see that 138 cubic feet of gas per hour are consumed by the furnace at that rate.

With the barometer at 28.9" and a 70° F temperature, the correction factor will be .945. If the local gas heating value is 935 BTU per cubic foot the calculations will be as follows:

$$138 \text{ cu ft/hr} \times .945 \text{ correction factor} \times 935 \text{ BTU/cu. ft.} = 121,933 \text{ BTU/Hr.}$$

The calculated firing rate of 121,933 BTU per hour is within the  $\pm 2\%$  tolerance of our nominal 120,000 furnace.

If the actual input is not within 2% of the furnace rating, with allowance being made for the permissible range of the regulator setting (0.3 inches W.C.), replace the orifice spuds with spud of the proper size.

**CAUTION:** Be sure to relight any gas appliance that were turned off at the start of this input check.

**ADJUSTMENT OF MANIFOLD GAS PRESSURE**

1. Turn gas off at main gas valve. Remove 1/8" plug in the main gas valve body and install proper manometer tube adapter fitting. Add fitting in burner box pressure reference hose to allow reading negative pressure.
2. Connect the "U" tube manometer as shown in Figure 19.

**NOTE:** The screw-off cap for the pressure regulator must be removed entirely to gain access to the adjustment screw. Loosening or tightening the cap does not adjust the flow of gas.

3. Refer to Figure 18 for location of pressure regulator adjustment cap and screw on main gas valve.
3. Turn gas and electrical supplies ON. Start furnace and observe manifold pressure on manometer.
4. Adjust manifold pressure by adjusting gas valve regulator screw: for natural gas, set at 3.5" W.C.

Natural Gas	3.5" W.C.
-------------	-----------

If gas valve regulator is turned in, or clockwise, manifold pressure is increased. If screw is turned out, or counterclockwise, manifold pressure will decrease.



**WARNING:** If manifold pressure is too high, an over-fire condition exists which could cause heat exchanger failure. If the manifold pressure is too low, sooting and eventual clogging of the heat exchanger could occur.



**WARNING:** Once the correct gas pressure to the burners has been established, turn the gas valve knob to OFF and turn the electrical supply switch to OFF; then remove the pressure tap at the gas valve and re-install the plug, using a compound (on the threads) resistant to the action of LP gases.

Turn the electrical and gas supplies back on, and with the burners in operation, check for gas leakage around the plug with a soap and water solution.



**WARNING:** Be sure that gas valve regulator cap and burner box to gas valve pressure reference hose is reconnected.

**ADJUSTMENT OF TEMPERATURE RISE**

The temperature rise, or temperature difference between the return air and the heated air from the furnace, must be within the range shown on the furnace rating plate and within the application limitations shown in Table 1. After the temperature rise has been determined, the cfm can be calculated.

After about 20 minutes of operation, determine the furnace temperature rise. Take readings of both the return air and the heated air in the ducts, about six feet from the furnace where they will not be affected by radiant heat.

Increase the blower speed to decrease the temperature rise; decrease the blower speed to increase the rise.

All direct-drive blowers have multi-speed motors. The blower motor speed taps are located in the control box in the blower compartment. Refer to Figure 20 and the unit wiring label to change the blower speed.

You may select a heating speed and a cooling speed. They may be the same speed or a different speed.

To use the same speed tap for heating and cooling, the "heat" terminal and "cool" terminal must be connected using a jumper wire and connected to the desired motor lead. Place all unused motor leads on "Park" terminals. Two are provided.



**CAUTION:** Do not energize more than one motor speed at a time or damage to the motor will result.

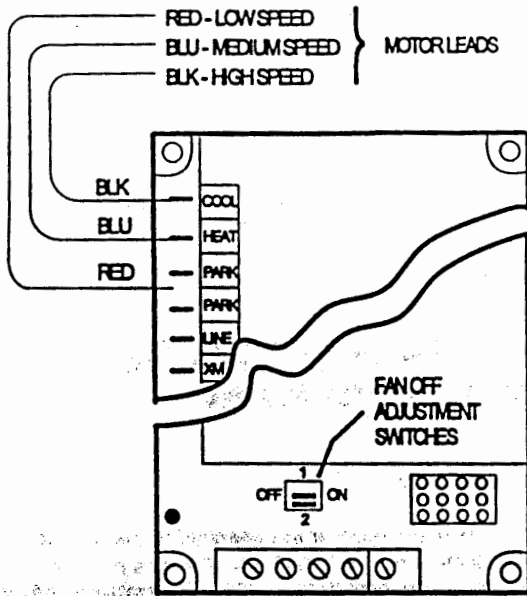


FIGURE 20 - TYPICAL HEAT/COOL SPEED TAP CONNECT & FAN OFF SETTING

**ADJUSTMENT OF FAN-OFF CONTROL SETTINGS**

This furnace is equipped with a time-on / time-off heating fan control. The fan "on" is fixed at 30 seconds. The fan "off" is field adjustable from 60 to 180 seconds. The fan "off" is factory set to 90 seconds. Adjust the "off" time by repositioning the fan off switches as located in Figure 20.

The fan-off setting must be long enough to adequately cool the furnace, but not so long that cold air is blown into the heated space. The fan-off timing may be adjusted by setting the option switches located (refer to Figure 20) on the control board as follows:

To Delay Fan-Off By:	Set Switch	
	1	2
60 Sec.	ON	ON
90 Sec.	OFF	ON
120 Sec.	ON	OFF
180 Sec.	OFF	OFF

**ACCESSORY CONNECTIONS**

The furnace control will allow power switching control of various accessories. See Figure 21 for connection details.

**Electronic Air Cleaner Connection**

Two 1/4" spade terminals (AC and AC N) for electronic air cleaner connections are located on the control board. The terminals provide 120 VAC (1.0 amp maximum) during circulating blower operation.

**Humidifier Connection**

Two 1/4" spade terminals (HUM and HUM N) for humidifier connections are located on the control board. The terminals provide 120 VAC (1.0 amp maximum) during heat speed operation of the circulating blower.

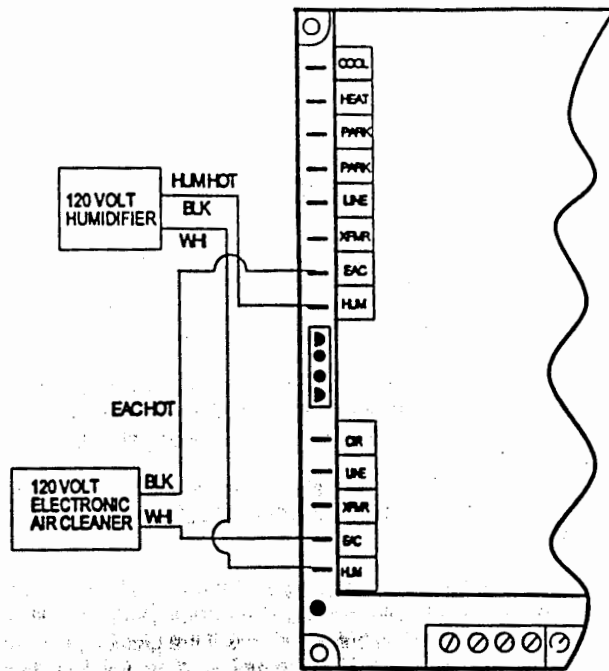


FIGURE 21 - ACCESSORY CONNECTIONS

**OPERATION AND MAINTENANCE**

**SEQUENCE OF OPERATION**

The following describes the sequence of operation of the furnace. Refer to the schematic wiring diagram in the back of this manual for component location.

**CONTINUOUS BLOWER**

On cooling/heating thermostats with fan switch, when the fan switch is set in the "ON" position, a circuit is completed between terminals R and G of the thermostat. The blower motor is energized through the cool fan terminal and runs on the selected speed.

**INTERMITTENT BLOWER - COOLING**

On cooling/heating thermostats with fan switch, when the fan switch is set in the "auto" position and the thermostat calls for cooling, a circuit is completed between the R, Y and G terminals. The motor is energized through the cool fan terminal and runs on the selected speed. The fan off setting is fixed at 60 seconds for SEER enhancement.

**HEATING CYCLE**

When the system switch is set on HEAT and the fan is set on AUTO, and the room thermostat calls for heat, a circuit is completed between terminals R and W of the thermostat. When the proper amount of combustion air is being provided, a pressure switch activates the ignition control

The ignition control provides a 17-second warm-up period. The gas valve then opens for seven seconds.

As gas starts to flow and ignition occurs, the flame sensor begins its sensing function. If a flame is detected within seven seconds after ignition, normal furnace operation continues until the thermostat circuit between R and W is opened. After flame is present for 30 seconds, the circulating blower is energized.

When the thermostat circuit opens, the ignition control is deenergized. With the ignition control deenergized, the gas flow stops and the burner flames are extinguished. The venter continues to operate for 15 seconds after the gas flow stops.

The blower motor continues to operate for the amount of time set by the fan-off delay switches located on the control board. The heating cycle is then complete, and the unit is ready for the start of the next heating cycle.

If flame is not detected within the seven second sensing period, the gas valve is deenergized. The control is equipped with a re-try option. This provides a 15 second wait following an unsuccessful ignition attempt (flame not detected).

After the 15 second wait, the ignition sequence is restarted with an additional 10 seconds of igniter warm-up time. If this ignition attempt is unsuccessful, one more re-try will be made before lockout.

A momentary loss of gas supply, flame blowout, or a shorted or open condition in the flame probe circuit will be sensed within 0.8 seconds.

The gas valve will deenergize and the control will restart the ignition sequence after waiting 15 seconds. Recycles will begin and the burner will operate normally if the gas supply returns, or the fault condition is corrected prior to the last ignition attempt. Otherwise, the control will lockout.

The control will repeat the ignition sequence for a total of four recycles if flame is lost within the first 10 seconds of establishment.

If flame is established for more than 10 seconds after ignition, the control will clear the ignition attempt (retry) counter. If flame is lost after 10 seconds, it will restart the ignition sequence. This can occur a maximum of five times.

During burner operation, a momentary loss of power of 50 milliseconds or longer will drop out the main gas valve. When the power is restored, the gas valve will remain deenergized and a restart of the ignition sequence will begin immediately.

### Hot Surface Ignition System



**WARNING:** Do not attempt to light this furnace by hand (with a match or any other means). There may be a potential shock hazard from the components of the hot surface ignition system. The furnace can only be lit automatically by its hot surface ignition system.

## MAINTENANCE

### Air Filters

The filters must be checked periodically for dirt accumulation. Dirty filters greatly restrict the flow of air and may cause damage to the system.

Clean the filters at least every three months. On new construction, check the filters every week for the first four weeks. Inspect the filters every three weeks after that, especially if the system is running constantly.

All filters used with the furnace are the high-velocity, cleanable type. Clean these filters by washing in warm water. Make sure to shake all the water out of the filter and have it reasonably dry before installing it in the furnace. When replacing filters, be sure to use the same size and type as originally supplied.

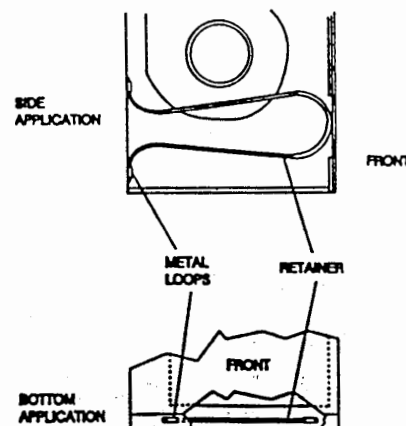


FIGURE 22 - FILTER RETAINER

### Filter Removal

The ends of the retainer are attached to the rear panel in two metal loops. Refer to Figure 22. The ends must be squeezed together to free them from the loops. The retainer may then be moved to the new location and the ends inserted in the loops on the rear panel at the new location. Loops are provided for retainer location to accommodate filter application on the bottom or either side of the furnace.

To remove a filter from the bottom location, push the closed end of the filter retainer to the left until it clears the lip on the front of the furnace base, which acts as a catch for the retainer. When the retainer is clear of the flange, it will pivot in the loops. Swing the retainer toward the center of the furnace. This will expose the filter to allow removal. To reinstall the filter, simply reverse this procedure.

### Lubrication

Blower motors in these furnaces are permanently lubricated and do not require periodic oiling.

## BLOWER CARE

Even with good filters properly in place, blower wheels and motors will become dust laden after long months of operation. The entire blower assembly should be inspected annually. If the motor and wheel are heavily coated with dust, they can be brushed and cleaned with a vacuum cleaner.

The procedure for removing the direct drive blower assembly for cleaning is as follows:

1. Disconnect the electrical supply to the furnace.
2. Remove the access panels.
3. Disconnect the two wire harness plugs from the top of the control box. Disconnect the condensate drain hose above the blower deck.
4. Remove the four screws holding the control box and position it out of the way.
5. Remove the screws which retain blower to blower deck.



6. Remove the blower assembly with the control wiring still attached.
7. Vacuum the motor and the blower using a soft brush attachment. Care must be used not to disturb any balance weights (clips) on the blower wheel vanes.
8. Before reinstalling the blower assembly, inspect the heat exchanger which is visible in the blower opening of the blower deck. If it requires cleaning, vacuum it with a soft brush attachment.
9. Reinstall the blower assembly. Replace mounting screws that hold the blower assembly to the front portion of the blower deck. Two mounting screws used on the sides of the blower are used for shipping purposes only, and are not necessary after the furnace has been installed.
10. Reinstall the control box and reconnect the wiring harness plugs.
11. Replace the access doors and restore the electrical supply to the unit.

### Burner Removal/Cleaning

The main burners should be checked periodically for dirt accumulation.

If cleaning is required, follow this procedure:

1. Turn off the electrical power to the unit.
2. Turn off the gas supply at the external manual shutoff valve and loosen the ground union joint.
3. Remove the upper access panel and remove the burner box cover.
4. Remove the screws that hold the burner box assembly to the vent panel and remove the assembly.
5. Remove burners from the burner assembly.
6. Burners may be cleaned by rinsing in hot water.
7. Reassemble the burners in the reverse order, making sure the burner shield is tightened securely in place.

### Cleaning the Heat Exchanger

1. Turn off the main manual gas valve external to the furnace.
2. Turn off electrical power to the furnace.
3. Remove the upper access panel and remove the burner box cover.
4. Disconnect wires from flame sensor, rollout switch and HSI igniter. Remove igniter **carefully**, as it is easily broken.



**CAUTION:** Label all wires prior to disconnection when servicing controls. Wiring errors can cause improper and dangerous operation. Verify proper operation after servicing.

5. Remove the screws that hold the burner box assembly to the vestibule panel and remove the assembly. The upper portion of the heat exchanger will now be exposed.
6. Remove the upper cover plate at the top of the furnace. Remove the internal baffle.
7. The upper portion of the heat exchanger is now exposed.
8. With a long flexible wire brush, clean inside each tube at both the top and bottom. The brush must pass around the rear heat exchanger tubes. Vacuum loose scale and dirt from each tube.
9. Clean - vacuum all burners.
10. Replace all components in reverse order. Reconnect all wiring.
11. Restore electrical power and gas supply to the furnace.
12. Check furnace operation.

### Cleaning the Secondary Heat Exchanger

1. Follow steps 1 thru 10 under "Cleaning the Primary Heat Exchanger."
2. Remove the vent piping from the venter housing. Disconnect the drain lines from the venter and from the condensate drain pan. Remove the venter blower and the condensate pan. The turbulators can then be gently removed from the secondary heat exchanger.
3. With a stiff wire brush, brush out loose scale or soot.
4. Vacuum the secondary heat exchanger.
5. Finish the cleaning procedure by following steps 10 thru 12 under "Cleaning the Primary Heat Exchanger."

### VENT/AIR INTAKE

Should it be necessary to service the vent/air intake system, the manufacturer recommends this service be conducted by a qualified service agency.

The operation of this appliance requires the reassembly and resealing of the vent/air intake system as specified on Page 10.

### TROUBLESHOOTING

The following visual checks should be made before troubleshooting:

1. Check to see that the power to the furnace and the ignition control module is ON.
2. The manual shutoff valves in the gas line to the furnace must be open.
3. Make sure all wiring connections are secure.
4. Review the sequence of operation.

Start the system by setting the thermostat above the room temperature. Observe the system's response. Then use the troubleshooting section in this manual to check the system's operation.

## FURNACE CONTROL DIAGNOSTICS

The furnace has built-in, self diagnostic capability. If a system problem occurs, a fault code is shown by a blinking LED. It is located behind a clear view port in the blower compartment door. DO NOT remove the furnace blower compartment panel OR turn off furnace power as either action will clear the control's memory of the fault.

The control continuously monitors its own operation and the operation of the system. If a failure occurs, the LED will indicate the failure code. If the failure is internal to the control, the light will stay on continuously. In this case, the entire control should be replaced as the control is not field repairable.

If the sensed failure is in the system (external to the control), the LED will flash in the following flash-pause sequences to indicate failure status.

Flash sequence codes 1 thru 5 are as follows. LED will turn "on" for 1/4 second and "off" for 1/4 second. This pattern will be repeated the number of times equal to the code. For example, six "on" flashes equals a number 6 fault code.

All flash code sequences are broken by a 2 second "off" period.

### **CONTINUOUS FLASHING** (1 sec "on" - 1 sec "off")

This indicates that flame was sensed when there was not a call for heat. With this fault code the control will also turn on both the inducer motor and supply air blower. This fault would typically be caused by a gas valve that leaks through or is slow closing.

### **1 FLASH**

This fault code indicates that flame could not be established. This no-light condition occurred 3 times during the call for heat before locking out. This may be caused by low gas pressure, faulty gas valve, faulty hot surface ignitor or burner problem.

### **2 FLASH**

This indicates that the normally open pressure switch(es) contacts are stuck in the closed position. The control confirms these contacts are open at the beginning of each heat cycle. This would indicate a faulty pressure switch or mis-wiring.

### **3 FLASH**

This indicates the normally open pressure switch(es) contact did not close at the beginning of the heat cycle. This could be caused by a number of problems; faulty inducer, blocked intake

or vent pipe, broken pressure switch hose or faulty pressure switch.

### **4 FLASH**

This indicates the limit switch has opened its normally closed contacts. With this fault code the control will operate the supply air blower and inducer. This condition may be caused by: dirty filter, improperly sized duct system, incorrect blower speed setting, incorrect firing rate or faulty blower motor.

### **5 FLASH**

This fault is indicated if the normally closed contacts in the rollout switch opens. The rollout control is manually reset. If it has opened, check for intake blockage, proper inducer operation, primary heat exchanger failure or burner problem. Be sure to reset the switch after correcting the failure condition.

*Normal Flame signal current is approximately  
1.6 - 1.8 microamps ( $\mu$ a)*

### **LED ON CONSTANTLY**

This indicates an internal fault in the furnace control discovered during its self-check procedure. Replace the control.

*NOTE: The control will blink one time when initially powered. This is normal and not an indication of any malfunction.*

### **RESET FROM LOCKOUT**

To reset the control from any lockout condition break the line voltage supply or 24 volt signal from the thermostat for 30 seconds.



**WARNING:** Do not try to repair controls. Replace defective controls with approved parts.

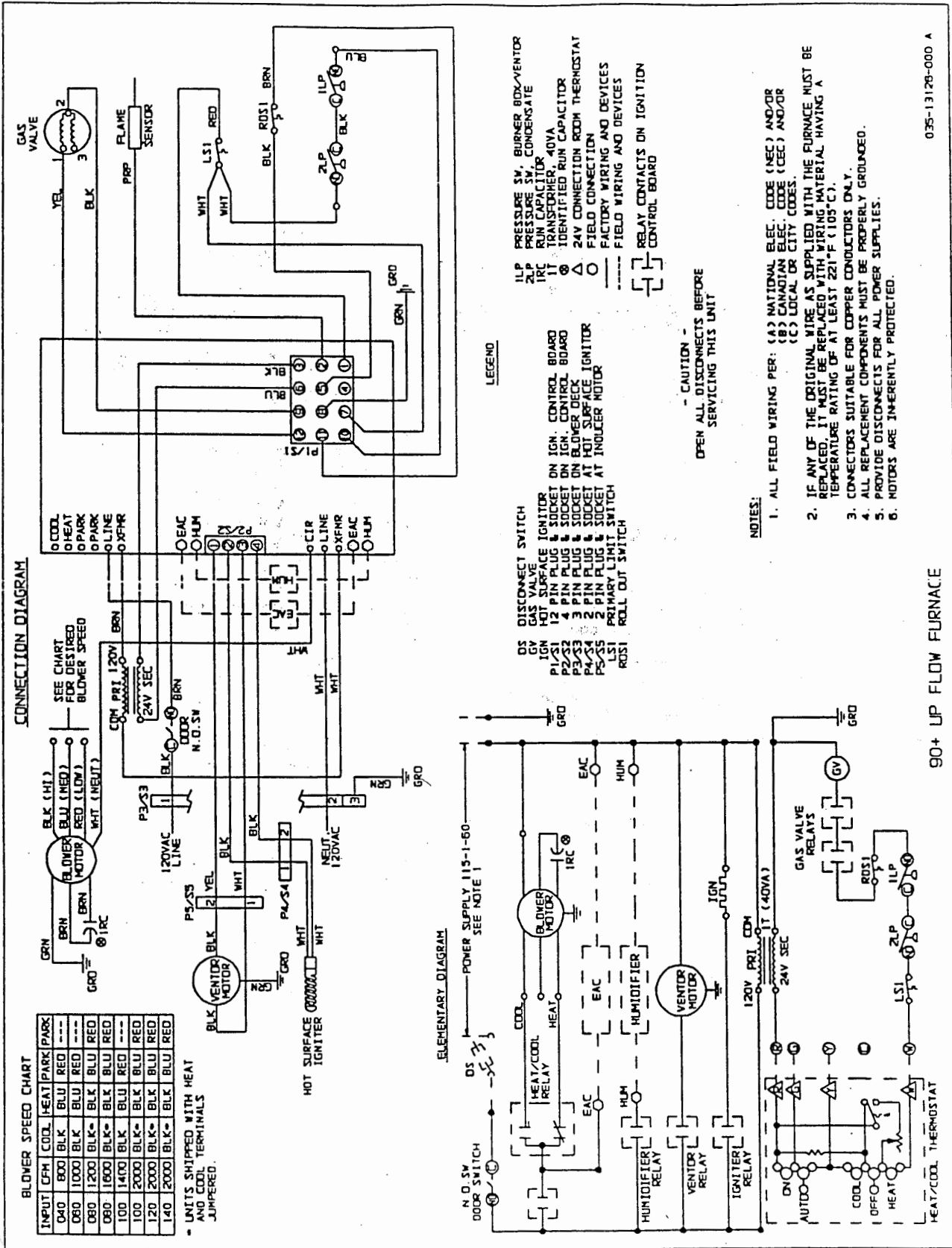


**WARNING:** Never adjust pressure switch to allow furnace operation.



**WARNING:** Never jump pressure switch or rewire in an attempt to allow furnace operation. To do so will allow furnace to operate under potentially hazardous conditions.

# UNIT WIRING DIAGRAM

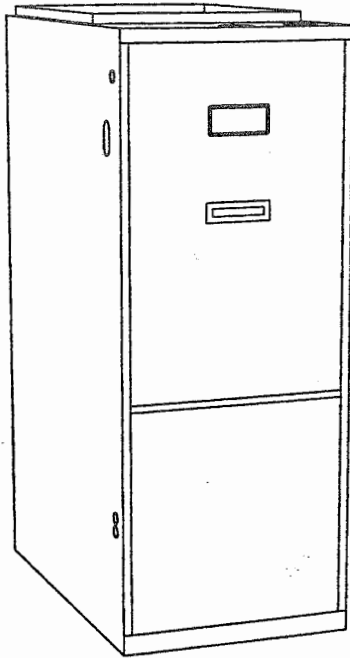




# DGU SERIES GAS FURNACES

## TECH SPEC

T-790 Rev.2  
(4/96)



### CONDENSING HIGH EFFICIENCY UPFLOW FURNACE 92.0 AFUE



#### DESCRIPTION

These Category IV, highly efficient, compact, sealed combustion, condensing type furnaces are designed for residential and commercial installations in a basement, closet, alcove, recreation room or garage where the ambient temperature is above 32°F. They may be either side wall or thru roof vented using approved plastic type combustion air and vent piping. All units are factory assembled, wired and tested to assure dependable and economical installation and operation.

#### WARRANTY

**Lifetime limited warranty on both heat exchangers to the original purchaser; a 20-year limited warranty from original installation date to subsequent purchaser.  
1-year limited parts warranty.**

#### FEATURES

- Compact, easy to install 45" cabinet.
- Full height blower compartment allows side return application without the use of a return air box.
- Blower-off delay for cooling SEER improvement.
- Easy to connect power/control wiring.
- Built-in, high level self diagnostics with fault code display.
- Low unit amp requirement for easy replacement application.
- Integrated control module for reliable, economical operation.
- Top intake and vent connection allows installation in narrow locations,
- Electronic Hot Surface Ignition saves fuel cost with increased dependability and reliability.
- Induced combustion system with inshot main burners for quiet, efficient operation.
- No special vent termination kit required.
- 100% shut off main gas valve for extra safety.
- PSC - multiple speed, direct drive motor with large, quiet blower.
- 24V, 40VA control transformer and blower relay supplied for add-on cooling.
- Hi-tech tubular aluminized steel primary heat exchanger.
- Secondary (condensing) heat exchanger of 29-4C high-grade stainless steel.
- Use of outdoor combustion air to reduce internal heat load and drafts along with reduced potential for corrosion caused by contaminated indoor combustion air.
- Timed on, adjustable off blower capability for maximum comfort.
- Blower door safety switch.
- Solid bottom to assure rattle free operation.
- Easy access from front of unit for cleaning, maintenance or service.
- Protection from intake, exhaust or condensate blockage.

### RATINGS AND PHYSICAL DATA

MODEL NUMBER	HTG. CAP. INPUT MBH	SS OUTPUT MBH	AFUE	AIR TEMP. RISE °F	CFM @ MEAN AIR TEMP. RISE	MAX. OUTLET AIR TEMP. °F	BLOWER			TOTAL UNIT AMPS
							DIA.	WIDTH	HP	
DGU04008U	40	37	92	35-65	588	165	9	6	1/4	9.0
DGU06010U	60	54	92	45-75	850	175	10	6	1/3	9.0
DGU08012U	80	73	92	35-65	1160	165	11	8	1/2	9.0
DGU08016U	80	75	92	30-60	1540	160	11	8	3/4	12.0
DGU10014U	100	93	92	45-75	1465	175	10	10	1/2	9.0
DGU10020U	100	93	92	30-60	1955	160	11	10	1	12.0
DGU12020U	120	111	92	45-75	1730	175	11	10	1	12.0

NOTES: 1. For altitudes above 2000 ft. reduce capacity 4% for each 1000 ft. above sea level.

2. Continuous return air temperature must not be below 55°F.

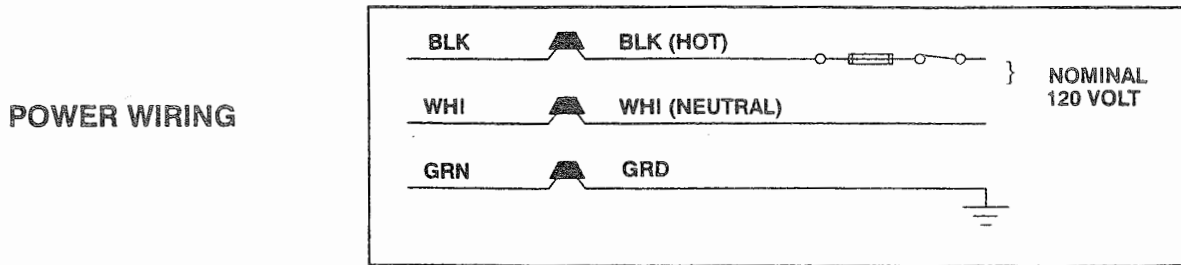
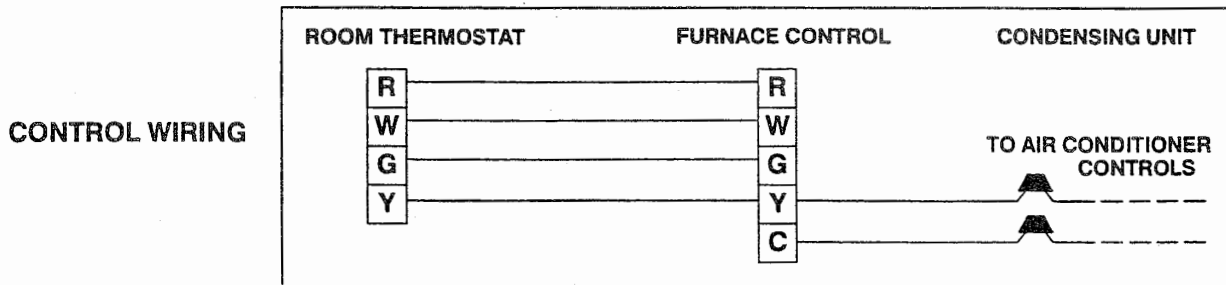
MODEL NUMBER	FILTER SIZE		ADD-ON COOLING		APPROX. OPER. WEIGHT
	SIDE	BOTTOM	TONS	CFM* @ .5 ESP	
DGU04008U	16x25	14x25	1, 1-1/2, 2	835	110
DGU06010U	16x25	16x25	1-1/2, 2, 2-1/2	1,115	130
DGU08012U	16x25	16x25	2, 2-1/2, 3	1,265	145
DGU08016U	16x25	20x25	3, 3-1/2, 4	1,650	155
DGU10014U	16x25	20x25	2-1/2, 3, 3-1/2	1,415	165
DGU10020U	(2) 16x25	20x25	3-1/2, 4, 5	2,025	170
DGU12020U	(2) 16x25	22x25	3-1/2, 4, 5	2,030	180

\* ESP (External Static Pressure) .5" WC is at furnace outlet ahead of cooling coil.

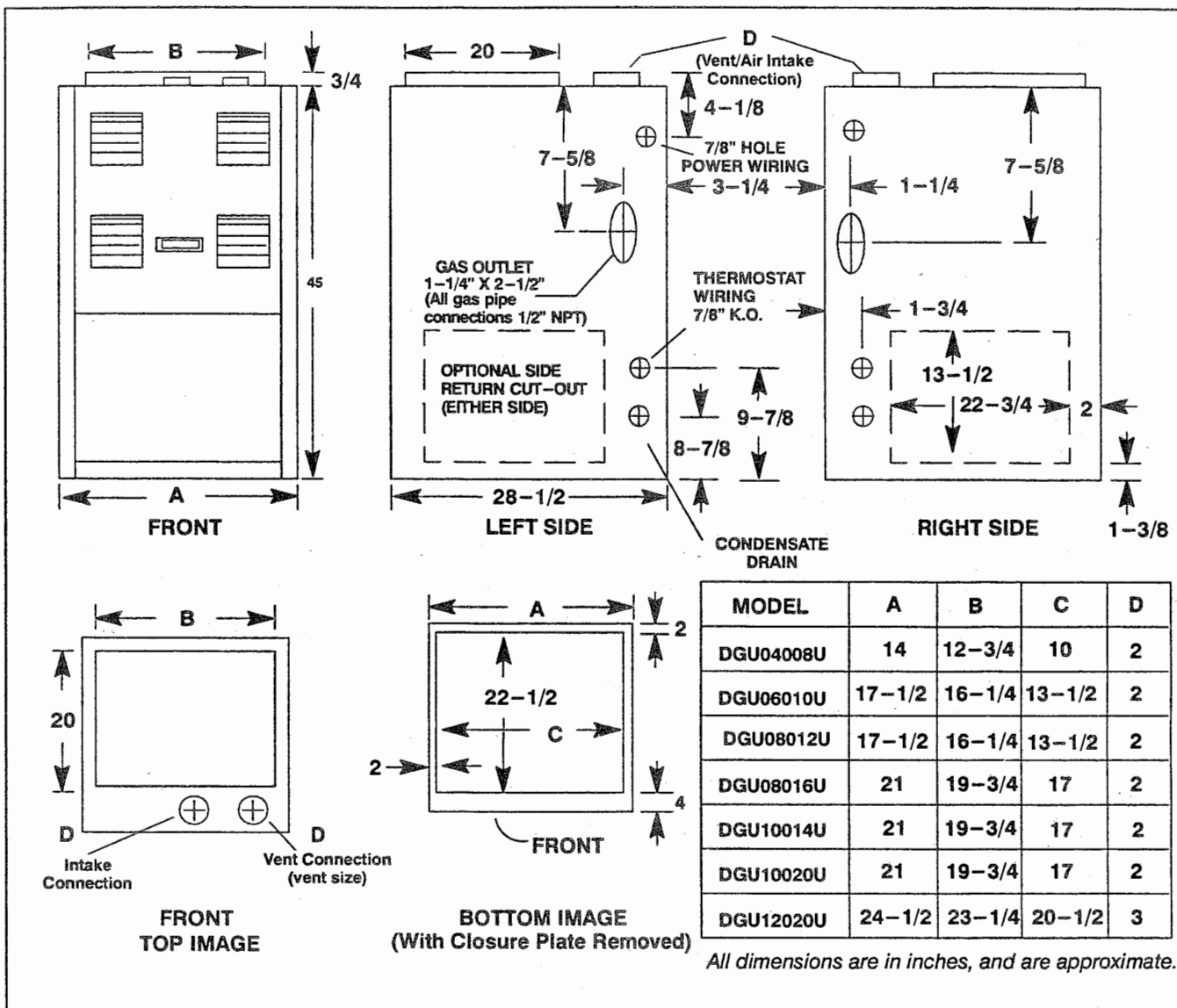
NOTES: 1. All filters must be high velocity cleanable type.

2. Air flows above 1800 CFM require either return from two sides or one side plus bottom.

### FIELD WIRING DIAGRAM



## DIMENSIONS



## VENT SIZING TABLE

MODEL	PIPE SIZE	MAX. ELBOWS PER TOTAL RUN			
		5-40 FT.	40-45 FT.	45-50 FT.	50-75 FT.
DGU04008U	2"	6	5	4	N/A
DGU06010U					
DGU08012U					
DGU08016U					
DGU10014U	3"	8	7	6	5
DGU10020U					
DGU12020U	3" Only	6	5	4	N/A

NOTE: 1. Must use the larger pipe size indicated.

## BLOWER PERFORMANCE

MODEL	SPEED TAP	EXTERNAL STATIC PRESSURE, INCHES WC									
		0.1	0.2	0.3	0.4	0.5	0.6	0.7	0.8	0.9	1.0
DGU04008U	HI	1051	1005	977	985	835	757	665	450	—	—
	MED	900	887	851	810	752	693	609	403	—	—
	LOW	—	581	577	569	542	468	—	—	—	—
DGU06010U	HI	1220	1200	1190	1152	1115	1065	1012	950	872	771
	MED	—	—	920	915	900	880	842	803	740	650
	LOW	—	—	725	729	715	700	681	653	600	525
DGU08012U	HI	1431	1395	1355	1317	1263	1226	1165	1101	1029	937
	MED	1188	1076	1065	1046	1023	994	955	906	842	752
	LOW	832	823	811	805	794	766	742	672	624	561
DGU08016U	HI	1879	1837	1794	1740	1688	1627	1559	1485	1406	1314
	MED	—	1379	1374	1348	1340	1313	1271	1232	1158	1078
	LOW	—	—	—	1196	1181	1141	1095	1053	1001	938
DGU10014U	HI	1742	1672	1602	1519	1433	1348	1232	1098	934	766
	MED	—	1390	1360	1320	1265	1176	1062	965	810	656
	LOW	—	—	1097	1061	1035	1000	927	830	708	574
DGU10020U	HI	2300	2229	2168	2100	2026	1939	1855	1758	1661	1546
	MED	1937	1897	1855	1808	1737	1673	1597	1511	1425	1305
	LOW	1579	1564	1533	1481	1461	1415	1350	1291	1205	1093
DGU12020U	HI	2366	2298	2226	2153	2065	1988	1890	1808	1712	1600
	MED	2000	1961	1920	1874	1821	1757	1685	1606	1510	1430
	LOW	1588	1578	1545	1525	1492	1455	1399	1340	1280	1163



These conditions are outside the heating operating range.

Airflow expressed in standard cubic feet per minute.

**NOTES:** 1. Return air is through side opposite motor (left side).

2. Air filters installed. All filters must be high velocity and cleanable type.

3. Motor voltage at 115 V.

4. Air flows above 1800 CFM require either return from two sides or one side plus bottom.

### ACCESSORIES

#### Propane (LP) Conversion Kit – 1NP0347

This accessory conversion kit may be used to convert natural gas (N) units for propane (LP) operation. Conversions should be made by qualified distributor or dealer personnel.

#### External Rack W/Filter – 1SR0302 (6 Pack)

Includes rack that mounts to side of furnace cabinet and cleanable filter.

#### Concentric Vent Termination – 1CT0301

For use through rooftop, sidewall. Allows combustion air to enter and exhaust to exit through single common hole.

#### Condensate Pump – 2CP03700101

#### Neutralizer Kit – 1NK0301

#### Bottom Return Filter Racks:

1BR0301 – 14"

1BR0302 – 17.5"

1BR0303 – 21"

1BR0304 – 24.5"

### Evcon Industries, Inc.

3110 North Mead  
P.O. Box 19014  
Wichita, KS 67204-9014