

INSTALLATION MANUAL

R-22 OUTDOOR SPLIT-SYSTEM HEAT PUMP

MODELS:
13 SEER - ERHQ SERIES
2 TO 3-1/2 TONS



CERTIFICATION APPLIES ONLY
WHEN THE COMPLETE
SYSTEM IS LISTED
WITH ARI.



ISO 9001
Certified Quality
Management System



TABLE OF CONTENTS

GENERAL	1	ELECTRICAL CONNECTIONS	5
SAFETY	1	SYSTEM OPERATION	6
UNIT INSTALLATION	2	INSTRUCTING THE OWNER	9
		WIRING DIAGRAM	10

LIST OF FIGURES

Typical Installation with Required Clearances	2	Outdoor Unit Control Box	5
Minimum Suction Line Form	3	Low Voltage Wiring	5
Excess Tubing	3	Demand Defrost Control Module	6
Insulation of Vapor Line	3	Defrost Operation Curves	8
Typical Quick Connect Refrigerant Line Set	4	Heat Pump Flow Diagram	9
Quick Connect Coupling Connections	4	Wiring Diagram	10

LIST OF TABLES

TEST Input Functionality	6	Defrost Initiate Curves	7
X/L Output Categories	6		

GENERAL

These outdoor heat pump units are designed to be connected to a matching UPG indoor coil. They are equipped with a solid core filter-drier located in the discharge line and a high pressure switch.

NOTE: These units are supplied with quick-connect coupling connections that are factory charged with refrigerant to be matched with the appropriate pre-charged line set, and UPG indoor coil.

The outdoor unit is designed to be placed near the perimeter of the home, typically alongside or at the back of the home, remote from the indoor coil. The outdoor unit has been factory run-tested and all components of the system are ready for easy, immediate installation.

SAFETY



This is a safety alert symbol. When you see this symbol on labels or in manuals, be alert to the potential for personal injury.

Understand and pay particular attention to the signal words **DANGER**, **WARNING**, or **CAUTION**.

DANGER indicates an **imminently** hazardous situation, which, if not avoided, **will result in death or serious injury**.

WARNING indicates a **potentially** hazardous situation, which, if not avoided, **could result in death or serious injury**.

CAUTION indicates a potentially hazardous situation, which, if not avoided **may result in minor or moderate injury**. It is also used to alert against unsafe practices and hazards involving only property damage

WARNING

Improper installation may create a condition where the operation of the product could cause personal injury or property damage. Improper installation, adjustment, alteration, service, or maintenance can cause injury or property damage. Refer to this manual for assistance or for additional information, consult a qualified contractor, installer, or service agency.

CAUTION

This product must be installed in strict compliance with the enclosed installation instructions and any applicable local, state, and national codes including, but not limited to building, electrical, and mechanical codes.

INSPECTION

As soon as a unit is received, it should be inspected for possible damage during transit. If damage is evident, the extent of the damage should be noted on the carrier's delivery receipt. A separate request for inspection by the carrier's agent should be made in writing. See Local Distributor for more information.

LIMITATIONS

The unit should be installed in accordance with all National, State, and Local Safety Codes and the limitations listed below:

1. Limitations for the indoor unit, coil, and appropriate accessories must also be observed.

- The outdoor unit must not be installed with any duct work in the air stream. The outdoor fan is the propeller type and is not designed to operate against any additional external static pressure.
- The maximum and minimum conditions for operation must be observed to assure a system that will give maximum performance with minimum service.

AIR TEMPERATURE AT OUTDOOR COIL, °F				AIR TEMPERATURE AT INDOOR COIL, °F			
Min.		Max.		Min.		Max.	
DB Cool	DB Heat	DB Cool	DB Heat	WB Cool	DB Heat	WB Cool	DB Heat
50	-10	115	75	57	50 ¹	72	80

- Operation below this temperature is permissible for a short period of time, during morning warm-up.
- The maximum allowable line length for this product is 75 feet.

UNIT INSTALLATION

LOCATION

Before starting the installation, select and check the suitability of the location for both the indoor and outdoor unit. Observe all limitations and clearance requirements.

The outdoor unit must have sufficient clearance for air entrance to the condenser coil, for air discharge, and for service access. See Figure 1.

NOTE: For multiple unit installations, units must be spaced a minimum of 18 inches apart. (Coil face to coil face.)

If the unit is to be installed on a hot sun exposed roof or a black-topped ground area, the unit should be raised sufficiently above the roof or ground to avoid taking the accumulated layer of hot air into the outdoor unit.

Provide an adequate structural support.

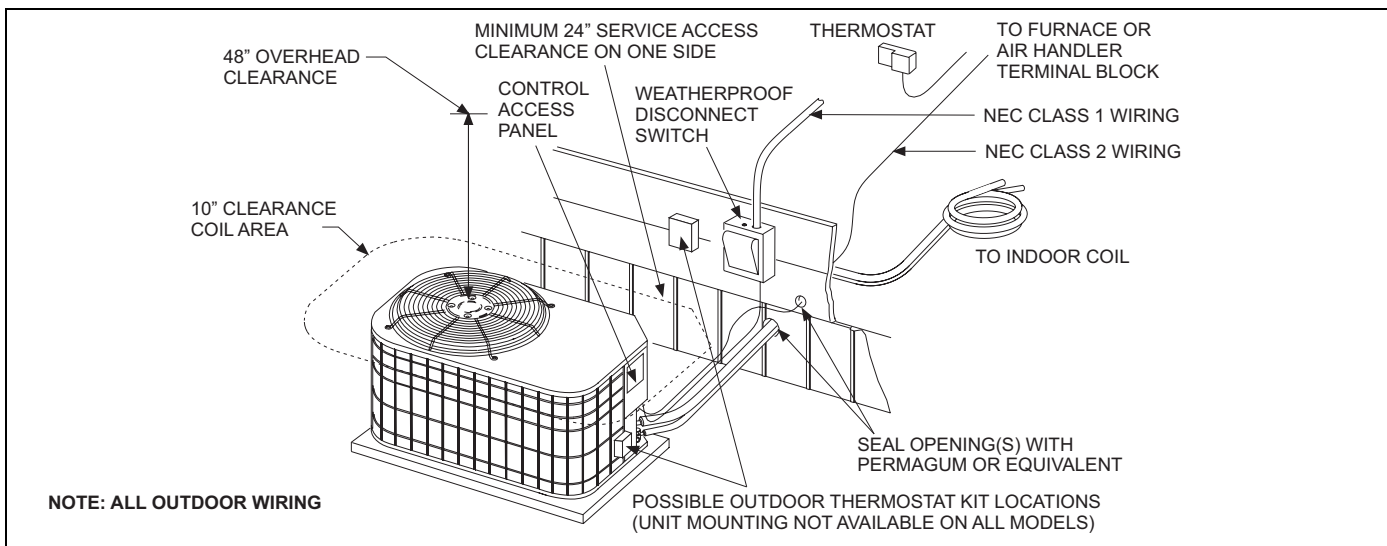

FIGURE 1: Typical Installation with Required Clearances

GROUND INSTALLATION

The unit may be installed at ground level on a solid base that will not shift or settle, causing strain on the refrigerant lines and possible leaks. Maintain the clearances shown in Figure 1 and install the unit in a level position.

Normal operating sound levels may be objectionable if the unit is placed directly under windows of certain rooms (bedrooms, study, etc.).

Condensate will drain from beneath the coil of the outdoor unit during the defrost cycle. Normally this condensate may be allowed to drain directly on the ground.

Elevate the unit sufficiently to prevent any blockage of the air entrances by snow in areas where there will be snow accumulation. Check the local weather bureau for the expected snow accumulation in your area.

Isolate the unit from rain gutters to avoid any possible wash out of the foundation.

WARNING

The outdoor unit should not be installed in an area where mud or ice could cause personal injury. Remember that condensate will drip from the unit coil during heat and defrost cycles and that this condensate will freeze when the temperature of the outdoor air is below 32°F.

CAUTION

Failure to do so or using a substitute drier or a granular type may result in damage to the equipment.

UNIT PLACEMENT

- Provide a base in the pre-determined location.
- Remove the shipping carton and inspect for possible damage.
- Compressor tie-down bolts should remain tightened.
- Position the unit on the base provided.

NOTE: Heat pumps will defrost periodically resulting in water drainage. The unit should not be located where water drainage may freeze and create a hazardous condition - such as sidewalks and steps.

LIQUID LINE FILTER-DRIER

The heat pumps have a solid core bi-flow filter/drier located on the liquid line.

NOTE: Replacements for the liquid line drier must be exactly the same as marked on the original factory drier. See Source 1 for O.E.M. replacement driers.

Filter-Drier Source 1 Part No.	Apply with Models 13 SEER
19312 / 1458-001	024
20738 / 6536-334	030, 036, 042

*As listed on the "Energy Guide yellow sticker on the unit.

OUTDOOR THERMOSTATS

(All installations of this heat pump in Manufactured Homes built per HUD standards SHALL have an outdoor thermostat installed at the time of installation by the installer. In accordance with HUD std. 3280.714 (a) (1) (ii). Outdoor thermostat, Part number 3024-6881/D shall be used and should be ordered at your nearest UPG Parts Source). See last page of these instructions. Select the proper location for mounting the outdoor thermostat (see instructions packed with outdoor thermostat).

INDOOR UNITS

Install the indoor coil in the furnace or air handler according to the installation instructions packed with each component.

REFRIGERANT LINES

IMPORTANT: Do not remove protective caps from couplings until pre-charged lines are routed and ready for final connection. Protective caps prevent dirt from entering couplings and contaminating system when connected together.

1. Check size and length of pre-charged refrigerant lines before installing.
 - a. Check the size of the pre-charged refrigerant lines to insure that they are correct for the model being installed.
 - b. Check the final routing of the tubing, and insure tubing will be of adequate length, with allowance for connection at the coil and outdoor unit.

The line set part number, size, and length are shown in the tabular data sheet. Do not use any line sets other than those shown.

2. Copper tubing will work-harden.
 - a. The pre-charged tubing should be handled carefully.
 - b. Do not bend or work the tubing any more than necessary. (The larger size tubing 3/4" for example, will work-harden rapidly as it is formed. As the tubing becomes harder, it is more susceptible to kinking and damage).
3. Forming Copper.
 - a. No attempt should be made to bend the suction line in a shorter radius than 12". See Figure 2.

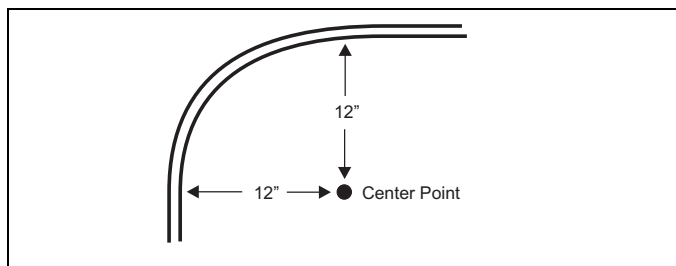

FIGURE 2: Minimum Suction Line Form

4. How to dispose of excess tubing.
 - a. Tubing may be longer than required. Coil excess tubing nearer the indoor coil rather than the outdoor unit.
 - b. Excess tubing must be coiled horizontally so the flow of refrigerant is from top to bottom of the coil and toward the outdoor unit. Another method is to form a horizontal "U" large enough to take care of excess. See Figure 3.

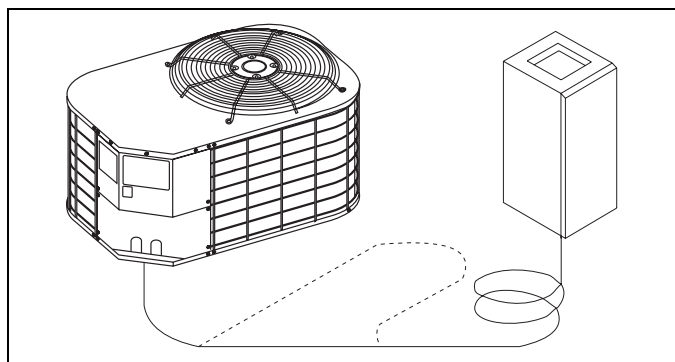

FIGURE 3: Excess Tubing

5. Slope tubing toward outdoor unit.
 - a. When the coil is above the outdoor unit, the suction line should be sloped with a fall of a least 1/4" per foot toward the outdoor unit.
 - b. When the outdoor unit is above the coil, the tubing should be sloped downward along lateral distance to the bottom, or from the vertical riser.
6. Insulation of suction line.
 - a. Standard suction lines come pre-insulated from the factory with 3/8" closed cell insulation, adequate for average installations.

NOTE: In regions of extreme temperatures and humidity, additional insulation may be required to prevent excessive condensation and serious loss of capacity.

- b. Do not insulate liquid and suction lines together.
- c. Liquid lines should not be insulated.
- d. Liquid lines should not be in bare contact with suction line. See Figure 4.

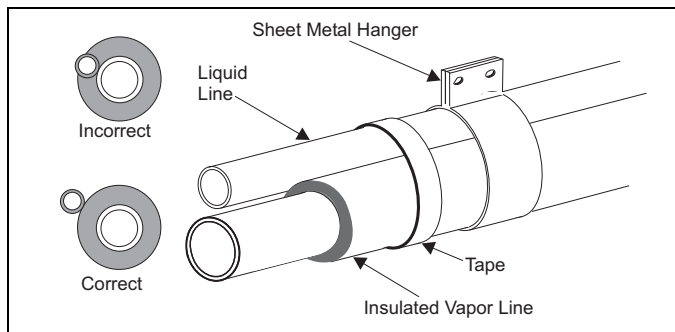

FIGURE 4: Insulation of Vapor Line

WARNING

Liquid refrigerant under pressure. Liquid refrigerant can cause severe frostbite. To avoid possible loss of sight and/or frostbite use eye protection (safety glasses or safety face shield). Wearing leather gloves will offer protection to hands.

7. Install refrigerant lines to indoor coil first. (The couplings without Schrader Valves are to be connected to the indoor coil. See Figure 5).
 - a. Form the tubing so it is properly aligned with the connections on the coil.
 - b. Remove plugs and caps from connections.
 - c. Check that the rubber seals in connection ends are intact.
 - d. Be sure surfaces are clean.
 - e. Lubricate the rubber seals with clean refrigerant oil and make connections.
 - f. Thread couplings together by hand to be sure they are not cross threaded. Tighten coupling so diaphragms are touching. (Do not puncture diaphragms at this time).

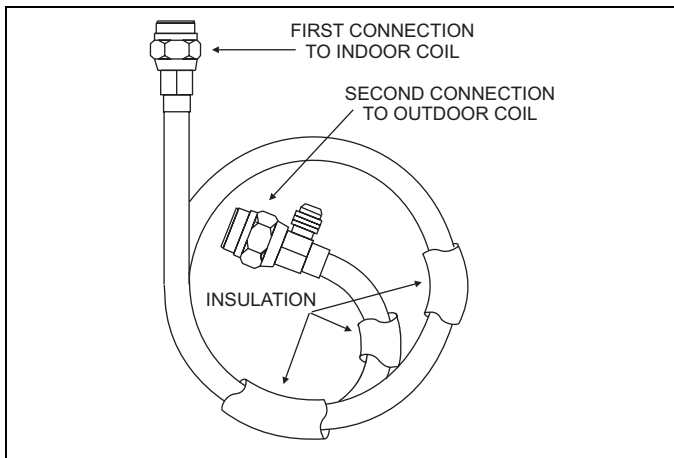

FIGURE 5: Typical Quick Connect Refrigerant Line Set

8. Install refrigerant line to outdoor unit. (The couplings with Schrader Valves are to be connected to the outdoor unit).
 - a. Form the tubing so it is properly aligned with the connections on the outdoor unit. Insure the Schrader Valves are accessible.
 - b. Check that the rubber seals in connection ends are intact.
 - c. Be sure surfaces are clean.
 - d. Lubricate the rubber seals with clean refrigerant oil and make connections.
 - e. Thread couplings together by hand to be sure they are not cross threaded. Tighten coupling so diaphragms are touching. (Do not puncture diaphragms at this time).
9. Tightening couplings.
 - a. Tighten indoor coil couplings with wrenches; using wrench on stationary fitting of coupling and liquid line fitting at coil while nut is being tightened. See Figure 6. Tighten the nut until the coupling bottoms out.
 - b. Then tighten an additional 1/6 turn to complete the knife edge seal.
 - c. Tighten outdoor unit couplings, with wrenches using a wrench on the stationary fitting of the coupling while nut is being tightened. Tighten the nut until the coupling bottoms out.
 - d. Then tighten an additional 1/6 turn to complete the knife edge seal.

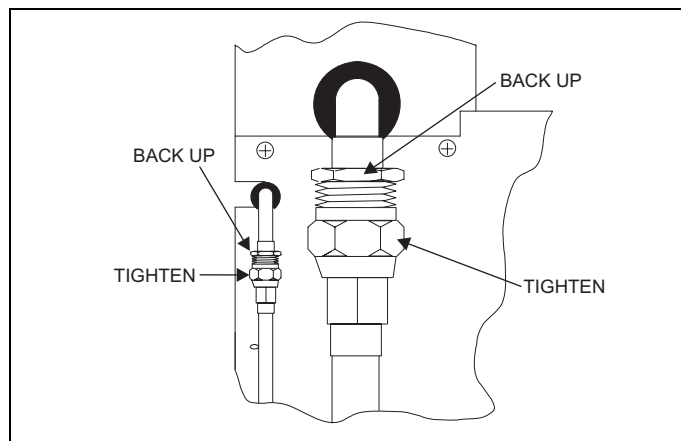

FIGURE 6: Quick Connect Coupling Connections

10. Check for leaks.
 - a. After the line set connections have been made they should be checked for leaks.
 - b. If the valves were kept clean and lubricated per instruction no leaks should be found.
 - c. Use leak detect solution or soap solution for leak testing. An electronic leak detector is recommended.

REFRIGERANT LINE SUPPORT

Refrigerant lines should be supported in a way that no dips or sags occur. We recommend four feet between supports. If refrigerant lines are to be attached to the home structure, care should be taken to eliminate the transmission of vibrations. Attach the refrigerant lines to the indoor coil first. Remove plugs from the indoor coil, then clean joints to be brazed. Braze refrigerant lines to the indoor coil. Attach refrigerant lines to the outdoor unit.

CHARGING AND LEAK TESTING

On systems with or without service valves the refrigerant should be recovered or recycled in accordance with EPA regulations. In some cases this may require putting piercing valves on both the high and low sides of the system.

WARNING

DO NOT vent refrigerant to the outdoors.

When recovering refrigerant from a system, with a burnout, follow a safe procedure due to possible contamination.

CAUTION

Avoid getting the refrigerant in the eyes or on the skin.

Contaminated refrigerant must be recovered and returned to the local refrigeration supply house for proper disposition.

ELECTRICAL CONNECTIONS

GENERAL INFORMATION & GROUNDING

Check the electrical supply to be sure that it meets the values specified on the unit nameplate and wiring label.

Power wiring, control (low voltage) wiring, disconnect switches and over current protection must be supplied by the installer. Wire size should be sized per NEC requirements.

⚠ CAUTION

All field wiring must USE COPPER CONDUCTORS ONLY and be in accordance with Local, National, Fire, Safety & Electrical Codes. This unit must be grounded with a separate ground wire in accordance with the above codes.

The complete connection diagram and schematic wiring label is located on the inside surface of the unit service access panel.

FIELD CONNECTIONS POWER WIRING

1. Install the proper size weatherproof disconnect switch outdoors and within sight of the unit.
2. Remove the screws from the control box cover and remove from unit.
3. Run power wiring from the disconnect switch to the unit.
4. Route wires from disconnect through power wiring opening provided and into the unit control box as shown in Figure 7.
5. Install the proper size time-delay fuses or circuit breaker, and make the power supply connections.

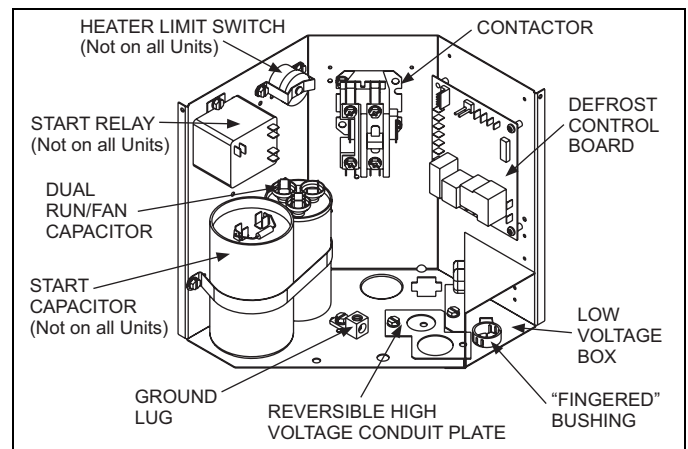

FIGURE 7: Outdoor Unit Control Box

FIELD CONNECTIONS CONTROL WIRING

1. Route low voltage wiring into bottom of control box as shown in Figure 7. Make low voltage wiring connections inside the low voltage box per Figure 8.
2. The complete connection diagram and schematic wiring label is located on the inside surface of the unit service access panel.
3. Replace the control box cover removed in Step 2.
4. All field wiring to be in accordance with national electrical codes (NEC) and/or local-city codes.
5. Mount the thermostat about 5 ft. above the floor, where it will be exposed to normal room air circulation. Do not place it on an outside wall or where it is exposed to the radiant effect from exposed glass or appliances, drafts from outside doors or supply air grilles.
6. Route the 24-volt control wiring (NEC Class 2) from the outdoor unit to the indoor unit and thermostat.

NOTE: To eliminate erratic operation, seal the hole in the wall at the thermostat with permagum or equivalent to prevent air drafts affecting the operation of in the thermostat.

NOTE: A Start Assist Kit is available and recommended for long line set applications or in areas of known low voltage problems.

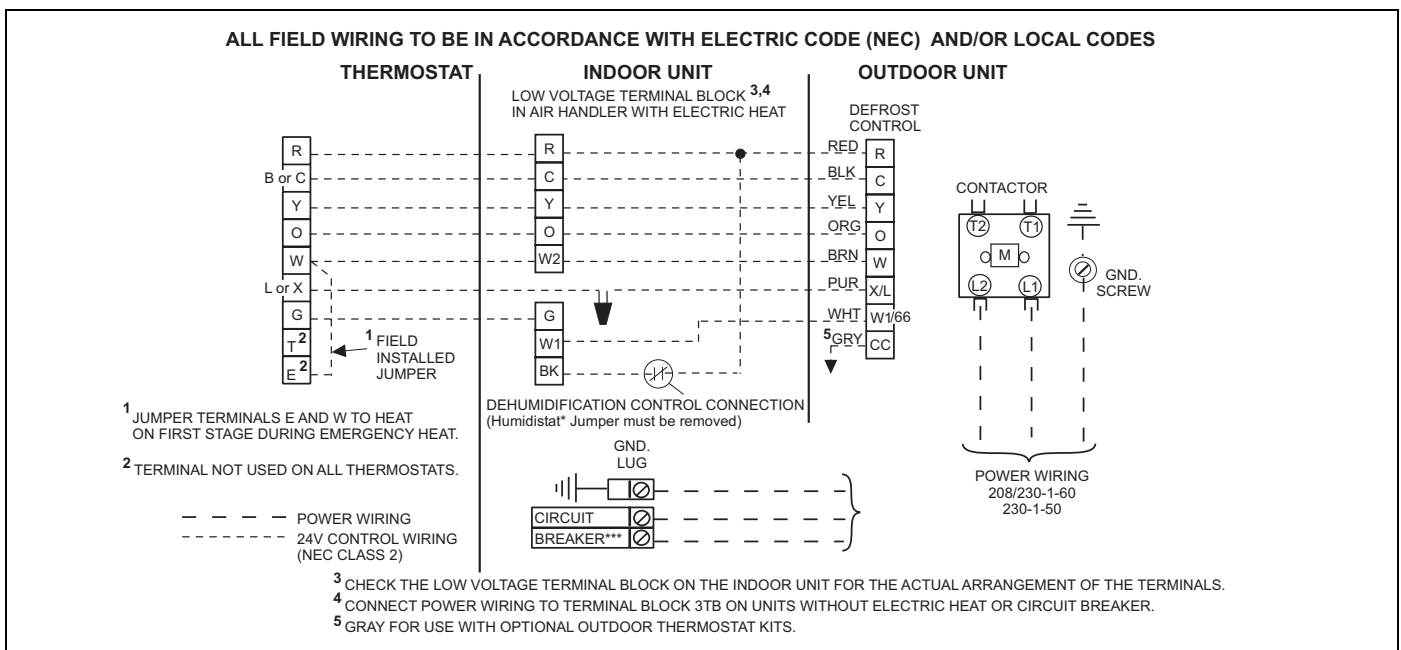

FIGURE 8: Low Voltage Wiring

SYSTEM OPERATION

ANTI-SHORT CYCLE DELAY

The control includes a five-minute anti-short cycle delay (ASCD) timer to prevent the compressor from short cycling after a power or thermostat signal interruption. The ASCD timer is applied when the control is first powered from the indoor unit thermostat and immediately following the completion of a compressor run cycle. The compressor and the outdoor fan will not operate during the five minutes that the timer is active.

The ASCD timer can be bypassed by connecting the TEST terminals for three seconds while the thermostat is calling for compressor operation (Y input signal energized).

LOW VOLTAGE DETECTION

The control monitors the transformer secondary (24 VAC) voltage and provides low voltage protection for the heat pump and its components. In particular, the control prevents contactor chatter during low voltage conditions. If the voltage drops below approximately 19 VAC, the control will continue to energize any relays that are already energized but will not energize any additional relays until the voltage level increases. If the voltage drops below approximately 16 VAC, the control will immediately de-energize the relay outputs and will not energize any relays until the voltage level increases.

TEST INPUT

The control includes a TEST input connector that can be used for various testing functions during installation and service. The TEST input connector is shown in Figure 9. The following table summarizes the behavior of the control when the two TEST pins are connected. More detailed descriptions of the various functions are included in other sections of this document.

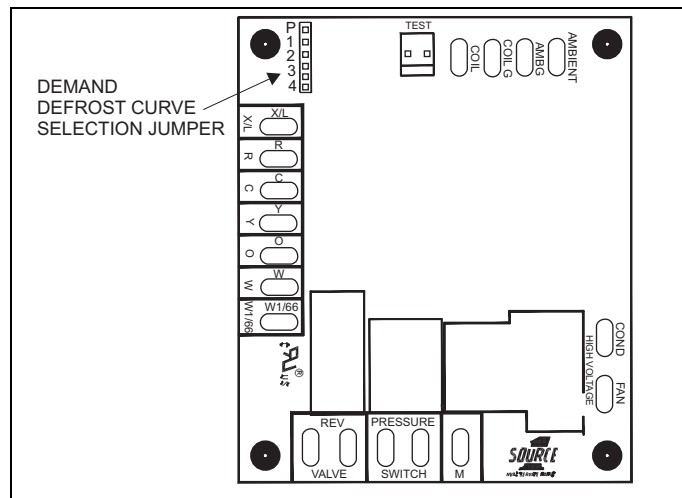

FIGURE 9: Demand Defrost Control Module

TABLE 1: TEST Input Functionality

Duration of connection (seconds)	Control behavior
Less than 2	No response
2-6	Bypass ASCD. If Y is present and pressure switch is closed, contactors will be energized.
	Clear lockout
More than 6	Initiate defrost cycle ignoring the liquid line and outdoor ambient temp. Energize X/L with active defrost curve flash code
Connection removed	Terminate defrost as normal.
Connection not removed	Continue defrost cycle and X/L flash code until TEST connection removed.

FAULT CODE DISPLAY

X/L Output

The X/L terminal of the heat pump control is typically connected to the X/L input of the room thermostat. The thermostat uses this signal to notify the homeowner of a problem with the heat pump using an LED or LCD display. When the control energizes the X/L terminal, the thermostat displays the flash code so the homeowner can see it.

TABLE 2: X/L Output Categories

Condition	X/L
Pressure Switch lockout - last mode of operation was heating	2 flashes
Pressure Switch lockout - last mode of operation was defrost	3 flashes

When the control locks out the compressor because of a pressure switch lockout, it will energize the X/L output as shown in Table 2. The control has a three second delay between fault code flashes.

DEFROST OPERATION

General

The control maintains proper airflow through the outdoor coil during heating operation by melting frost and ice that may form on the coil. Frost may accumulate unevenly in different sections of the coil because of the arrangement of the refrigeration circuit within the coil. The control may initiate a defrost cycle even when the coil is not completely covered with frost. This is normal operation.

The control regulates the defrost operation of the heat pump.

- Defrost is based on accumulated compressor run time, outdoor coil temperature, and outdoor ambient temperature.

The control will cause the unit to operate in the normal heating mode until it determines that a defrost cycle is needed.

All defrost timings are based on accumulated compressor run time.

Operation

The defrost mode is equivalent to the cooling mode except that the outdoor fan motor is de-energized. The control shall do the following to initiate a defrost cycle.

- De-energize the outdoor fan
- Energize the reversing valve
- Energize the auxiliary heat output through the W1/66 terminal.
- Begin the maximum defrost cycle length timer

If the call for heating (Y) is removed from the control during the defrost cycle, it will terminate the defrost cycle and de-energize the compressor. The control will also stop the defrost cycle length timer but not reset it. When the control receives another call for heating, it will restart the defrost cycle and the timer at the point at which the call for heating was removed. This will happen only if the liquid line temperature conditions allow defrost to occur.

Defrost Curves

The control uses a set of defrost curve parameters that are selected using the defrost curve selection jumper. The location of the defrost curve selection jumper is shown in Figures 10. Table 3 shows the jumper position that is appropriate for each heat pump model. Jumper position 4 is not used and the control will not allow the compressor to operate when the jumper is in this position.

Defrost Curve Selection

The factory activates the correct defrost curve during production. They will place the defrost curve selection jumper in the P position or in a numbered position appropriate for the specific heat pump model. You should not have to change the defrost curve selection jumper during initial installation.

If the jumper is inadvertently moved, it should be placed in the appropriate numbered location based on the model number and Table 3. If the factory has activated the curve using the P position, the jumper may also be returned to that position. If, however, the factory has not activated the curve in the P position and the jumper is placed in the P position, the control will not energize the compressor. The control will also not energize the compressor if the defrost curve selection jumper is in a numbered position that is not described in Table 3 or if the defrost curve selection jumper is missing. The control will display the proper fault code when a defrost curve jumper error is present. If the jumper is missing, the control will behave as if the jumper was in the P position. If the jumper is placed in a numbered position, the defrost curve selected by the jumper will override the defrost curve activated at the factory until the jumper is returned to the P position. The control will display the active defrost curve using the X/L terminal when the heat pump is operating in a defrost cycle that has been forced using the TEST inputs.

It will also display the active defrost curve using the X/L terminal when the operational mode is being displayed using the LED's. For instance, the X/L output will be energized with two flashes when defrost curve 2 is active. The control only reads the jumper input when the Y and W thermostat inputs are de-energized. If a jumper position is changed while either of these inputs is energized, the control will not act upon the jumper changes until the thermostat calls are de-energized or power (24 VAC) to the control is cycled.

Defrost Cycle Initiation

The control will allow the heat pump to operate in the heating mode until the combination of outdoor ambient and outdoor coil temperatures indicate that a defrost cycle is necessary.

The control will initiate a defrost cycle when the liquid line temperature is below the initiate point for the measured ambient temperature (See Figure 10) continuously for 4-1/2 minutes. This delay eliminates unnecessary defrost cycles caused by refrigeration surges such as those that occur at the start of a heating cycle.

TABLE 3: Defrost Initiate Curves

Defrost Curve Selection Jumper Position	1	2	3	4
13 Seer	All	None	None	None

The control will initiate a defrost cycle every 6 hours (accumulated compressor run time) to recirculate refrigerant lubricants. This forced defrost timer will be reset and restarted following the completion or termination of a defrost cycle.

The control will also initiate a defrost cycle when the TEST terminals are shorted. This feature allows an installer or service technician to start a defrost cycle immediately as required. When the TEST terminals are shorted for more than six seconds with a Y input energized and the pressure switch input is closed, the ASCD will be bypassed and the compressor and the W1/66 terminal to auxiliary heat will be energized.

When the TEST inputs are used to force a defrost cycle, the control will ignore the state of the liquid line temperature and outdoor ambient temperature inputs. The coil does not have to be cold and the outdoor temperature does not have to be within a certain range for the heat pump to be forced into a defrost cycle. After the TEST input jumper is removed, the defrost mode will be terminated as normal. The defrost cycle length timer will not be started until the TEST input is removed. If the TEST terminals remain shorted, the control will keep the unit in defrost mode.

Defrost Inhibition

The control will not initiate a defrost cycle if the liquid line temperature is above 40F unless the defrost cycle is forced using the TEST input.

The control will not initiate a defrost cycle when the outdoor ambient temperature is below -25F or above 55F unless the defrost cycle is forced using the TEST input.

The control will also prevent a defrost cycle from being initiated too soon after the initiation of the previous defrost cycle. When power is applied to the control and after the completion or termination of each defrost cycle, the control will start a 40-minute timer. When this timer expires, the control will allow another defrost cycle when needed. The timer is based on accumulated compressor run time.

Defrost Termination

The control will terminate the defrost cycle immediately after the liquid line temperature reaches 80F or after eight minutes of defrost operation.

The control will do the following to terminate a defrost cycle.

- Energize the outdoor fan
- De-energize the reversing valve
- De-energize the auxiliary heat output through the W1/66 terminal
- Reset and restart the 40-minute defrost inhibit timer

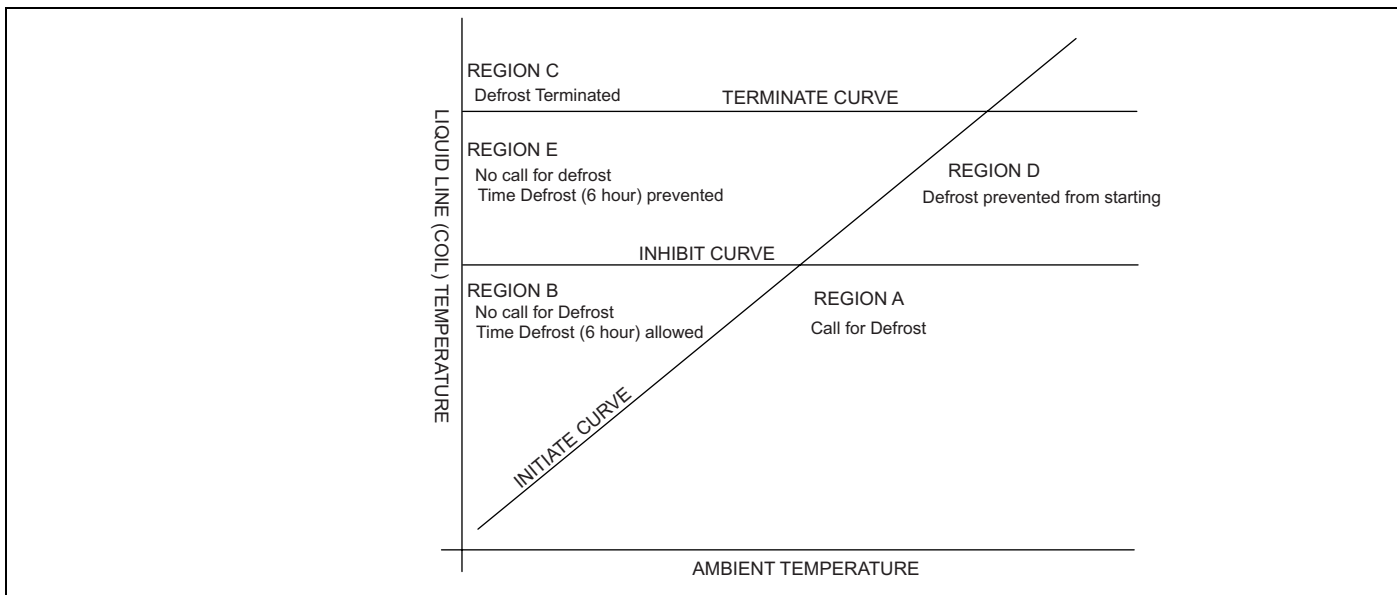

FIGURE 10: Defrost Operation Curves

COOLING OPERATION

During cooling operation, the control will receive thermostat signals at the Y and O input terminals. The control will energize the M compressor output terminal. This signal energizes the coil of the compressor contactor causing the compressor to run. The control also delivers power to the COND FAN terminals causing the outdoor fan to operate. The control energizes the REV VALVE terminal with 24VAC to switch the reversing valve.

HEATING OPERATION

During normal heating mode, the control will receive a thermostat signal at the Y input terminal. The control will energize the M compressor output terminal. This signal energizes the coil of the compressor contactor causing the compressor to run. The control also delivers power to the COND FAN terminals causing the outdoor fan to operate. The reversing valve is not energized in heating mode.

EMERGENCY HEAT

When the thermostat calls for emergency heat operation (W signal without a Y signal), the control will de-energize the compressor and energize the W1/66 terminal immediately.

PRESSURE SWITCH FAULT & LOCKOUT

The heat pump is equipped with a pressure switch and an optional low pressure switch that are connected to the control at the pressure switch terminals. If the pressure switch input opens for more than 40 milliseconds, the control will de-energize the compressor. If the pressure switch closes and a thermostat call for compressor operation is present, the control will apply the five-minute anti-short cycle delay timer and start the compressor when the timer expires.

When the compressor is started following a pressure switch fault, the control will start a six-hour timer based on accumulated compressor run time. If the control senses another opening of the pressure switch before the timer expires, it will cause a soft lockout condition. The second opening of the pressure switch must be greater than 160 milliseconds for the lockout to occur. If the second opening is between 40 and 160 milliseconds, the control will de-energize the compressor but not

cause a soft lockout condition. If the control does not sense a second pressure switch opening before the six-hour timer expires, the timer and counter will be reset.

During the soft lockout mode, the control will de-energize the compressor and energize the X/L output with the appropriate flash code.

The control will reset the soft lockout condition when any of the following occur following removal of the fault condition.

1. Power is cycled to the R or Y inputs of the control. This will cause the soft lockout condition to be reset when the thermostat is satisfied or when the thermostat is set to SYSTEM OFF and back to HEAT or COOL mode.

2. The TEST terminals are shorted for more than two seconds.

When the soft lockout condition is reset, the control will stop displaying the fault code and will respond to thermostat inputs normally.

INDICATIONS OF PROPER OPERATION

Cooling

Cooling operation is the same as any conventional air conditioning unit.

1. The outdoor fan should be running, with warm air being discharged from the top of the unit.
2. The indoor blower (furnace or air handler) will be operating, discharging cool air from the ducts. Coils or other parts in the air circuit should be cleaned as often as necessary to keep the unit clean. Use a brush, vacuum cleaner attachment, or other suitable means.
3. The vapor line at the outdoor unit will feel cool to the touch.
4. The liquid line at the outdoor unit will feel warm to the touch.

Heating

Indications of proper Heating operation is as follows:

1. The outdoor fan should be running, with cool air being discharged from the top of the unit.
2. The indoor blower (furnace or air handler) will be operating, discharging warm air from the ducts.
3. The vapor line at the outdoor unit will feel warm to the touch.
4. The liquid line at the outdoor unit will feel cool to the touch.

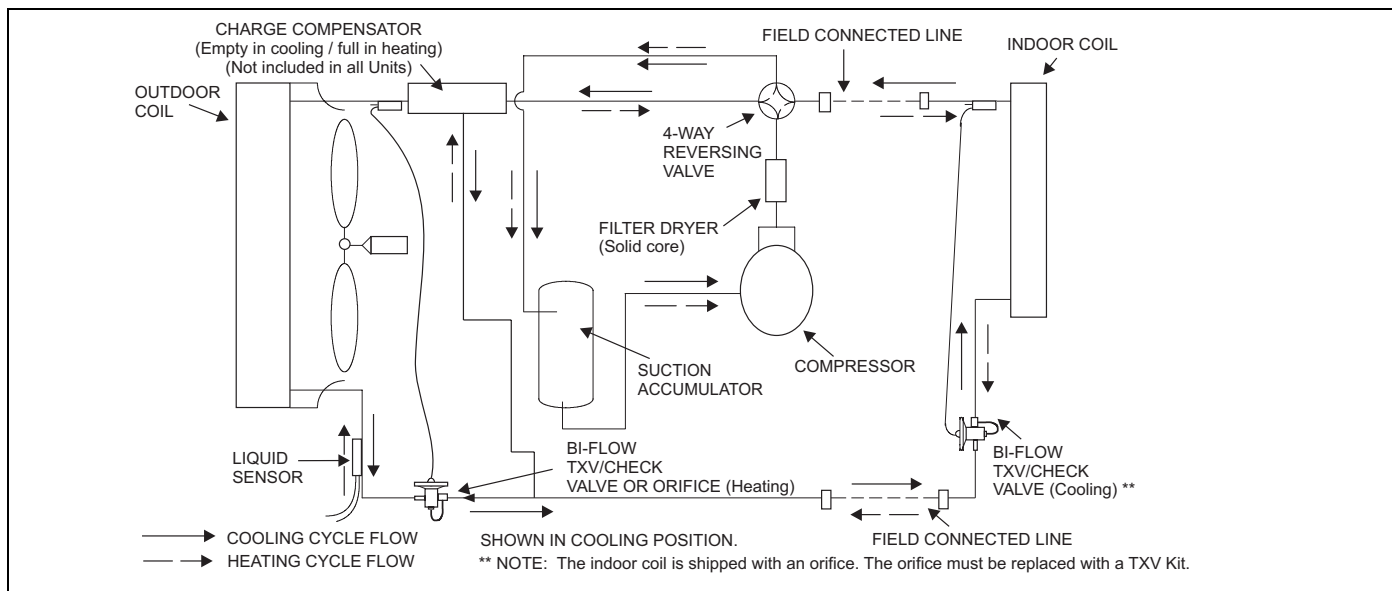

FIGURE 11: Heat Pump Flow Diagram

INSTRUCTING THE OWNER

Assist owner with processing warranty cards and/or online registration. Review Owners Guide and provide a copy to the owner and guidance on proper operation and maintenance. Instruct the owner or the operator how to start, stop and adjust temperature setting.

When applicable, instruct the owner that the compressor is equipped with a crankcase heater to prevent the migration of refrigerant to the compressor during the "OFF" cycle. The heater is energized only when the unit is not running. If the main switch is disconnected for long periods of shut down, do not attempt to start the unit until 8 hours after the switch has been connected. This will allow sufficient time for all liquid refrigerant to be driven out of the compressor.

The installer should also instruct the owner on proper operation and maintenance of all other system components.

MAINTENANCE

1. Dirt should not be allowed to accumulate on the outdoor coils or other parts in the air circuit. Clean as often as necessary to keep the unit clean. Use a brush, vacuum cleaner attachment, or other suitable means.

2. The outdoor fan motor is permanently lubricated and does not require periodic oiling.
3. If the coil needs to be cleaned, it should be washed with Calgon Coilclean (mix one part Coilclean to seven parts water). Allow solution to remain on coil for 30 minutes before rinsing with clean water. Solution should not be permitted to come in contact with painted surfaces.
4. Refer to the furnace or air handler instructions for filter and blower motor maintenance.
5. The indoor coil and drain pan should be inspected and cleaned regularly to prevent odors and assure proper drainage.

CAUTION

IT IS UNLAWFUL TO KNOWINGLY VENT, RELEASE OR DISCHARGE REFRIGERANT INTO THE OPEN AIR DURING REPAIR, SERVICE, MAINTENANCE OR THE FINAL DISPOSAL OF THIS UNIT.

WHEN THE SYSTEM IS FUNCTIONING PROPERLY AND THE OWNER HAS BEEN FULLY INSTRUCTED, SECURE THE OWNER'S APPROVAL.

WIRING DIAGRAM

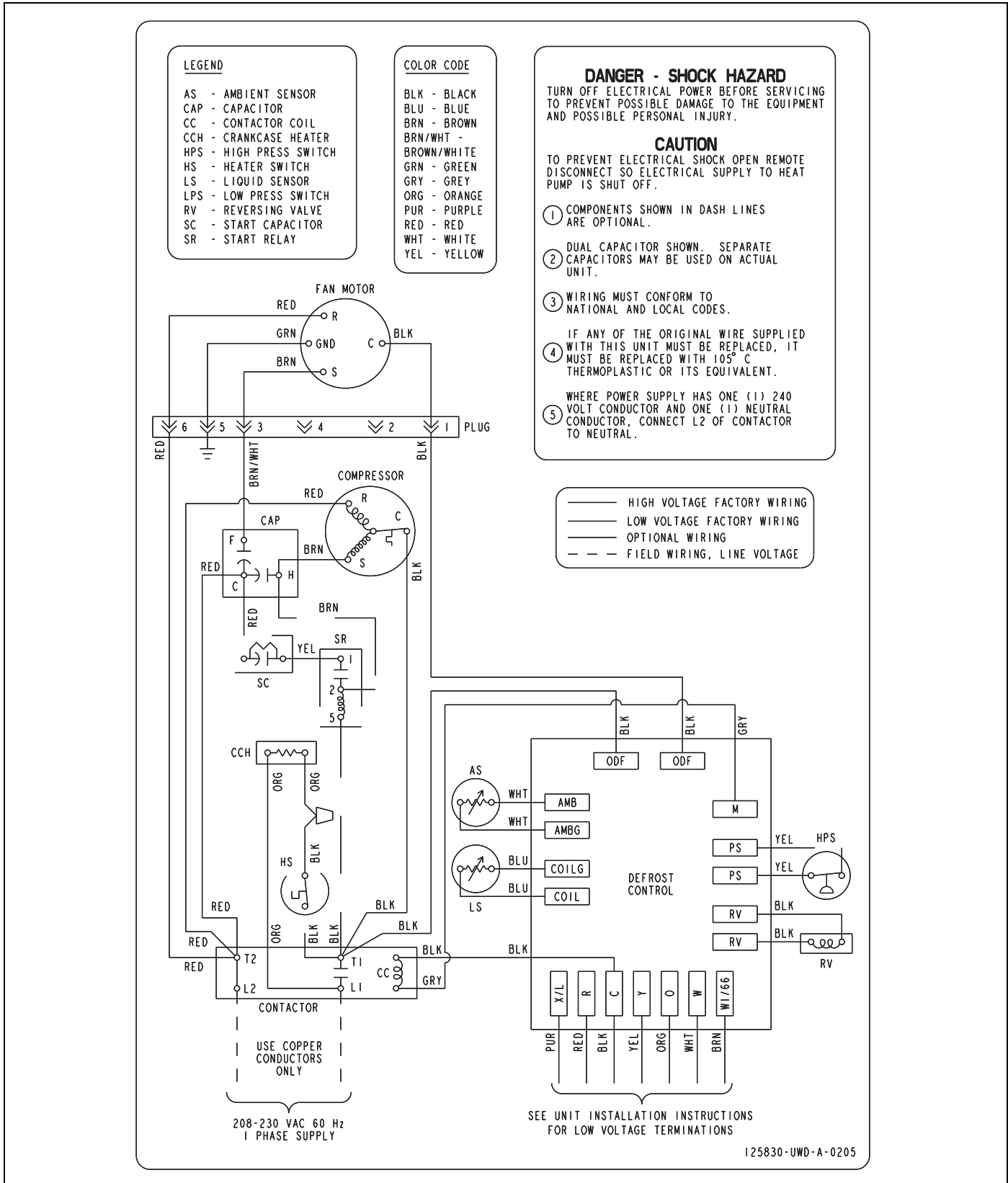

FIGURE 12: Wiring Diagram

NOTES

