



## SELECTION AND INSTALLATION INSTRUCTIONS conversion from natural gas to propane gas for model WGH

### **WARNING**

This conversion kit shall be installed by a qualified service agency in accordance with the manufacturer's instructions and all applicable codes and requirements of the authority having jurisdiction. If the information in these instructions is not followed exactly, a fire or explosion may result causing property damage, personal injury or loss of life. The qualified service agency performing this work assumes responsibility for the proper conversion of this furnace with this kit.

### **AVERTISSEMENT**

Cet ensemble de conversion ne doit être installé que par le représentant d'un organisme qualifié et conformément aux instructions du fabricant et à tous les codes et exigences applicables de l'autorité compétente. Quiconque ne respecte pas à la lettre les instructions dans le présent manuel risque de déclencher un incendie ou une explosion entraînant des dommages matériels, des lésions corporelles ou la perte de vies humaines. L'organisme qualifié qui effectue les travaux est responsable de la conversion correcte de ce générateur d'air chaud à l'aide de cet ensemble.

The propane kits appearing in this bulletin are for use with units which are going to be installed between 0 and 2000 ft. elevation. If a unit is to be installed at higher elevations, a special "high altitude" propane orifice kit must be ordered in addition to the propane conversion kits shown here. See Hamilton Bulletin 75-537-VHHP for selection of "high altitude" orifice kits.

When converting units to propane at elevations over 2000 ft., the main burner orifices in the propane conversion kit must be replaced with the orifices from the "high altitude" orifice kit. The remaining components of the propane kit, those other than the main burner orifices, are still required to complete the conversion to propane gas, regardless of the elevation at which the unit is installed.

### Identifying the Model, Control Code and Date of Manufacture

Figure 2.1 on the next page explains Hamilton WGH unit heater model number designations and serial number designations. Markings pertinent to verifying correct application of the conversion kit are identified and explained in detail. **All prerequisites must be satisfied before the unit is deemed convertible.**

1. The first three characters in the model number are letters. These letters identify the style of unit heater. These first three characters must be WGH for it to be convertible.
2. The control code for the unit to be converted must be 34.
3. Finally, the serial number shown in Figure 2.2 calls out the date the unit was built. Any unit manufactured after the 12th week of 1998, is acceptable for conversion.

**Figure 2.1**  
**Model Number Designations**

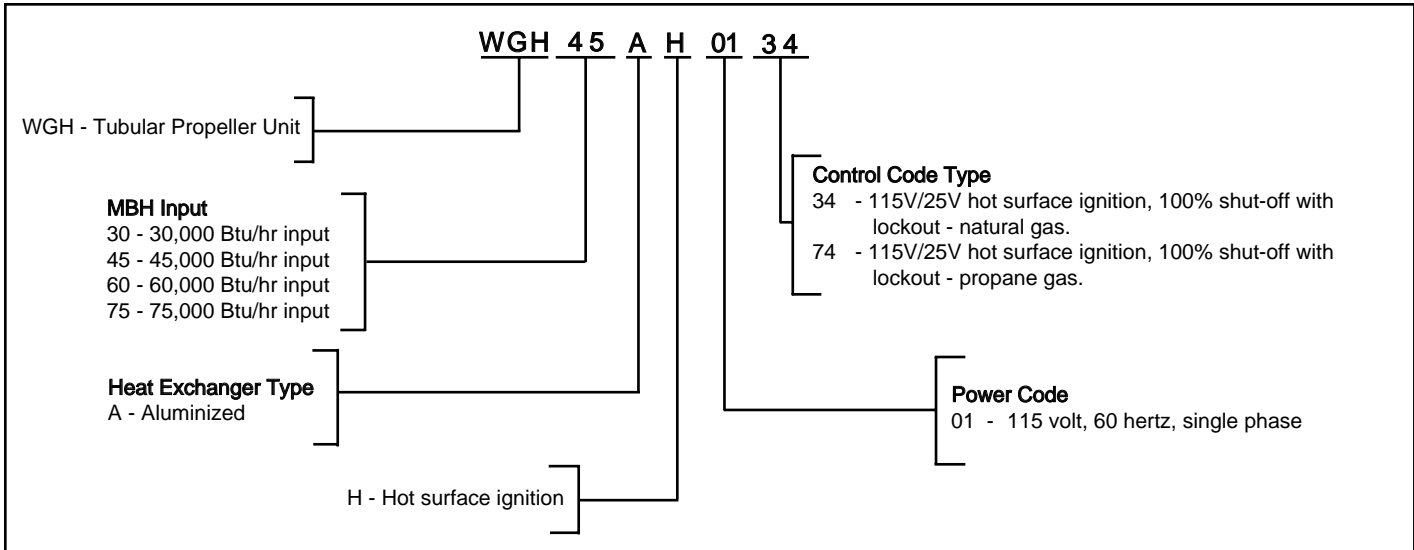

**Figure 2.2**  
**Serial Number Designations**

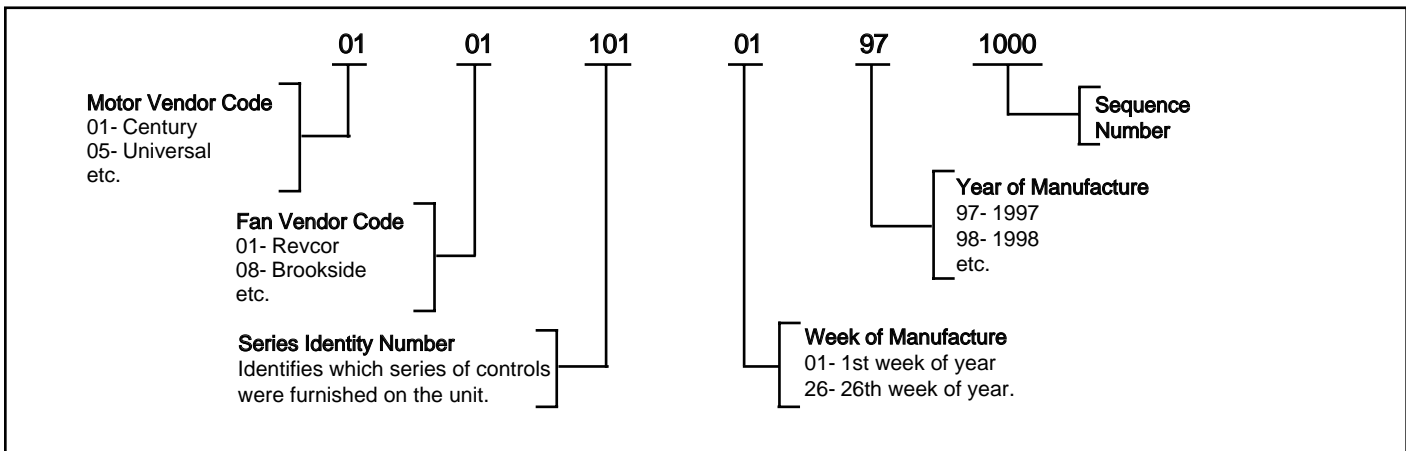

## Installation of Kit

Conversion of any kit is the responsibility of, and the risk of the person making the conversion.

### **CAUTION**

Gas supply shall be shut-off prior to disconnecting the electrical power, before proceeding with the conversion. Failure to do so could result in fire, explosion or electrical shock.

1. Read these instructions carefully. Failure to follow instructions can damage product or cause a hazardous condition.
2. This conversion kit must be installed by a qualified service person.
3. This conversion kit is for converting the WGH30, WGH45, WGH60 and WGH75 models from natural gas to propane gas at 0 – 2,000' elevations.
4. This kit contains the following:
  - Five (5) #56 propane orifices
  - A conversion rating plate
  - A combination gas control (gas valve) conversion kit containing:
    - a cap screw
    - an adjustment screw
    - spring
    - label
5. Prior to servicing, set the thermostat to the lowest setting. Shut off the gas supply to the unit. Disconnect the electrical power to the unit.

## Conversion

### CAUTION

Shut-off the gas supplies and disconnect the electrical power before servicing the heater.

1. Remove the access panel to the heater.
2. Disconnect the gas supply to the heater.
3. Remove the electrical connections from the gas valve. This should not require the use of tools.
4. Remove the four (4) screws holding the manifold to the burner box. This will allow for the removal of the manifold and gas valve assembly.
5. Remove the orifices from the manifold assembly and place them where they can be used if the heater should need to be converted back to natural gas.
6. Insert the #56 propane orifices from the kit into the manifold assembly. If you are converting an WGH30, WGH45, or WGH60 heater you will have extra orifices, which should be discarded. Tighten the orifices using a wrench so that they are gas tight.
7. Convert the combination gas valve by following the instructions in the regulator kit.
8. Affix the Propane Rating Plate label on the heater, near the serial plate on the same panel as the common replacement parts label.
9. Place the manifold assembly back on the burner box using the four (4) screws.
10. Replace the electrical connections to the gas valve.
11. Verify that the igniter and sensor are in the same location and have not been damaged.
12. Connect the gas supply to the heater.

## Check

1. Place pressure taps on both the inlet and outlet pressure tap of the gas valve.
2. Connect a pressure-measuring device capable of reading inches of water column on both the inlet and outlet pressure tap.
3. Place the unit in operation. Verify the proper ignition sequence. The inlet pressure should be 11" - 14" water column. The manifold pressure should be 10" water column.
4. There are no adjustments that can be made to the burner flame. Some yellow in the flame is acceptable as long as no carbon (black soot) is being formed.  
  
Make certain to verify the input rate as described in item #7 below.
5. Turn the heater off and replace the inlet and outlet pressure tap plugs.
6. Place the heater back into service and leak test the inlet and outlet pressure tap plugs as well as the connection between the gas valve and the manifold pipe.
7. See the original rating plate for the unit heater's rated input. The input can be verified at any time simply by checking the correct main burner orifice size and manifold pressure. This information is presented on the conversion kit rating plate.

**Figure 4.1**  
**WGH Unit Heater Component Identification**

