

INSTALLATION INSTRUCTION

OUTDOOR SPLIT-SYSTEM AIR CONDITIONER MODELS: 10, 12 AND 14 SEER 1.5 TO 5 TONS

TABLE OF CONTENTS

GENERAL INFORMATION	2
INSPECTION	2
REFERENCE	2
LIMITATIONS	2
INSTALLATION	4
OUTDOOR UNIT	4
INDOOR UNITS	4
REFRIGERANT LINE (SWEAT FIT)	4
INSULATION OF VAPOR LINE	4
RE-ASSEMBLING, BRAZING AND CLEANING OF JOINT CONNECTIONS	4
REFRIGERANT LINE SUPPORT	5
CHARGING AND LEAK TESTING	5
TOTAL LINE LENGTH	5
ORIFICE SELECTION (ON SWEAT FIT COILS) ...	5
REFRIGERANT VALVE OPERATION	5
REFRIGERANT LINE (QUICK CONNECT UNITS) .	6
OIL TRAPPING	8
CHECKOUT PROCEDURE	11
SYSTEM OPERATION CHECKOUT	11

**CAUTION: READ ALL SAFETY GUIDES
BEFORE YOU START TO INSTALL
YOUR FURNACE.**

SAVE THIS MANUAL

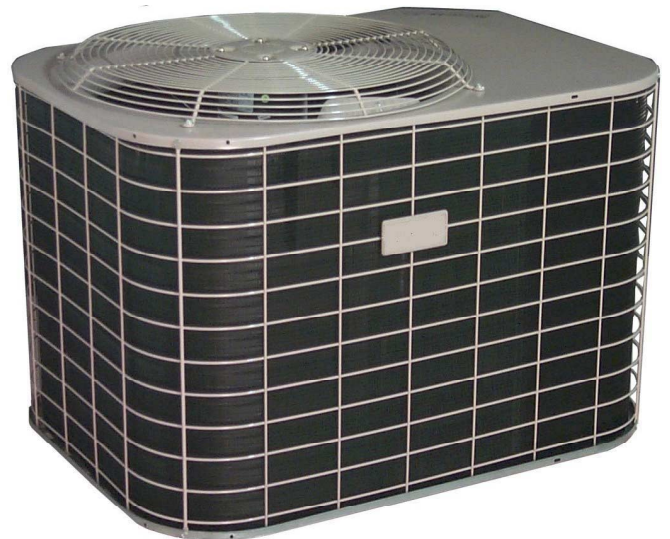

GENERAL INFORMATION

These outdoor condensing units are designed to be connected to a matching UPG indoor coil. They are equipped with a filter-drier located in the liquid line. One of two types of connection lines are required, depending on the model:

- Units with sweat-fit base valve connections are factory charged with refrigerant for a matching UPG indoor coil, plus 15 feet of field supplied line.
- Units with quick-connect coupling connections are factory charged with refrigerant to be matched with the appropriate precharged line set, and UPG indoor coil.

The outdoor unit is designed to be placed near the perimeter of the home, typically alongside or at the back of the home, remote from the indoor coil. The outdoor unit has been factory run-tested and all components of the system are ready for easy, immediate installation.

INSPECTION

Check the unit thoroughly for shipping damage, Unusually rough handling during shipment may loosen fan motors, compressors, or other components. Be sure that the unit is ready to operate before installing it. If there is damage, file a claim with the shipper.

REFERENCE

Use this instruction in conjunction with the instructions for the appropriate indoor unit, air moving system and accessories.

Installer should pay particular attention to the words NOTE, CAUTION and WARNING.

NOTES are intended to clarify or make the installation easier.

CAUTIONS identify procedures which, if not followed carefully, could result in personal injury, property damage or equipment damage.

WARNINGS are given to alert the installer that severe personal injury, death or equipment damage may result if installation procedures are not followed properly.

LIMITATIONS

The unit should be installed in accordance with all national and local codes and regulations which govern the installation of this type of equipment. In lieu of local codes, the equipment should be installed in accordance with National Electric Code, and in accordance with the recommendations made by the National Board of Fire Underwriters.

Limitations for the indoor unit, coil and appropriate accessories must also be observed.

The outdoor unit must not be installed with any duct work in the air stream. The outdoor fan is the propeller type and is not designed to operate against any additional external static pressure.

The maximum and minimum conditions for operation must be observed to assure a system that will give maximum performance with minimum service.

▲ CAUTION

The manufacturer is not responsible for the performance of a mismatched system. The outdoor unit must be installed with a compatible indoor unit as designated in the specification data or in the Directory of Certified Unitary Heat Pumps published by the Air Conditioning and Refrigeration Institute. Using unmatched components may not only affect the performance of the system, but may also void the warranty of the equipment.

Do not install any coil in a furnace which is to be operated during the heating season without attaching the refrigerant lines to the coil. Allowing the coil charge to enter the refrigerant lines prevents excessive refrigerant pressure build-up and possible coil damage.

Table 1: APPLICATION LIMITATIONS

Ambient Air Temperature on Outdoor Coil		Air Temperature on Indoor Coil	
Min. °DB	Max. °DB	Min.	Max.
50	120	57	72

Check Electrical Power Supply

The electrical power should be checked to determine if adequate power is available, and near constant voltage can be maintained. If there is any question concerning the power supply, contact the local power company for corrections; otherwise, unsatisfactory performance may result.

Selecting the Best Heat Pump Location

Several important factors must be considered before selecting the site for the outdoor unit:

- Distance to indoor coil
- Proximity to the structure
- Proximity to vents and exhaust systems
- Ability to service
- Sound transmission
- Air circulation
- Wind direction
- Relationship between structure, sun, and unit
- Distance from power source
- Water drainage
- Local codes

Locate the outdoor unit near enough to the indoor coil vicinity to eliminate lengthy refrigerant line runs. Do not locate the outdoor unit so it discharges air under eaves or gutters. Rain or snow melt-off should not be able to run off a roof and down upon the unit. Be sure vents are not located upwind from the outdoor unit.

A minimum clearance of 18 inches is required for service at the control panel and compressor compartments access. A 10 inch clearance is required for the air inlet to the outdoor coil around the perimeter of the unit. The air discharge of the unit requires a 60 inch clearance between the top of the unit and any obstruction. See Figure 1.

The length of the refrigerant tubing, between the outdoor unit and indoor coil, should be as short as possible to avoid capacity and efficiency loss. Excessive spacing of the outdoor unit from the home can lead to the refrigerant lines being restricted by trampling or by being punctured by lawn mowers. Locate the outdoor unit away from bedroom windows or other rooms where sound might be objectionable.

Adverse effects of prevailing winds, blowing snow or sleet onto the outdoor coil can be eliminated by placing the outdoor

unit where the wind does not blow across the unit. Trees, shrubs, corners of buildings and fences standing off from the coil can reduce capacity loss due to wind chill effect.

Provide ample clearance from shrubs to allow adequate air to pass across the outdoor coil without leaves or branches being pulled into the coil.

Consideration should be given to the distance and routing of electrical service that would have to be run to connect the outdoor unit.

It is recommended the outdoor unit be mounted upon a solid base that will not shift or settle. Top of base should be two inches above grade. Thought should be given to water drainage away from the outdoor unit. Drain holes in the base pan must be kept clear.

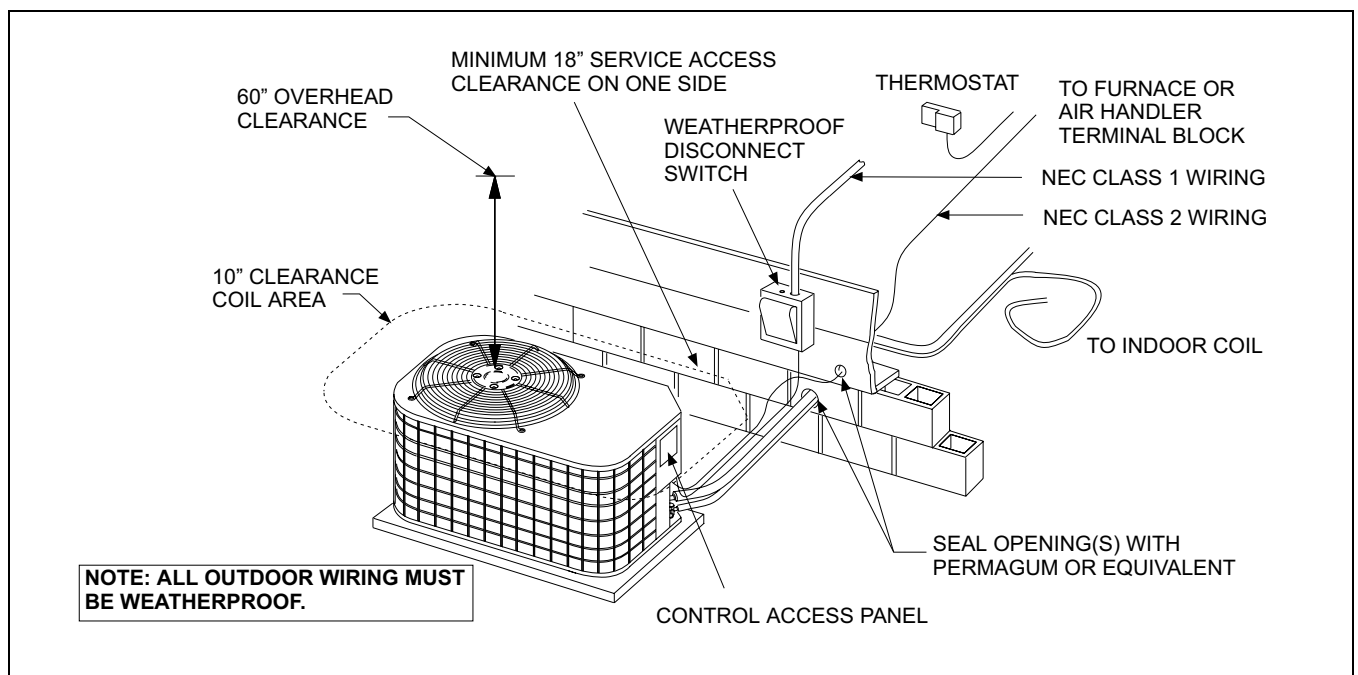

FIGURE 1 : TYPICAL RESIDENTIAL OUTDOOR UNIT LOCATION

INSTALLATION

OUTDOOR UNIT

After the site has been selected, a solid base pad that will not shift or settle should be provided. The base pad should not come in contact with the foundation or side of the structure because sound may be transmitted to the residence. The pad should be located far enough away from the structure so the outdoor unit is not closer than its minimum distances. See Figure 1. Set the outdoor unit upon the pad with care to avoid damage..

CAUTION

Do not remove the protective caps or plugs from the unit refrigerant connections until the refrigerant lines are run and ready for final connection. If this procedure is not observed, dirt and other particles will get into the system and plug various orifices and small tubes.

INDOOR UNITS

Install the indoor coil in the furnace or air handler according to the installation instructions packed with each component.

REFRIGERANT LINE (SWEAT FIT)

The following steps are very important when setting up a refrigeration system and need to be followed completely to insure that a strong, flexible and leak tight system is obtained.

The installation of the copper refrigerant tubing must be done with care to obtain reliable, trouble-free operation.

1. Selection of proper refrigerant tubing grade and size.
2. Refrigerant line routing, cutting and fitting.
3. Insulating the vapor line.
4. Connecting the refrigerant lines to the indoor coil and outdoor unit.
5. Proper preparation of joint connections.
6. Reassembling, cleaning and brazing the joint connections.
7. Pressure leak test all joints.
8. Evacuate refrigerant lines and indoor coil.
9. Charging refrigeration system (See Tabular Data Sheet if the line length is other than 15 feet).

Use only ACR grade copper tubing and keep ends sealed until joints are made.

The correct diameters of the refrigerant lines are listed in the Tabular Data Sheet.

For best performance, select routing of refrigerant lines for minimum distance and fewest number of bends.

Determine the path that the refrigerant lines will follow.

Starting at either the indoor coil or the outdoor unit refrigerant line connections, carefully measure, cut, de-burr and fit copper refrigerant lines along the path previously determined.

NOTE: If it is necessary for bends to be formed in the vapor line, the radius should not be less than 12 inches.

Cut ends of the copper tubing square.

Remove all burrs from tubing with a reamer, file or de-burring tool.

When the indoor coil is above the outdoor unit, the vapor line should be sloped toward the outdoor unit with a fall of at least 1/4 inch per 5 feet.

INSULATION OF VAPOR LINE

Insulate vapor line with 3/8" (or that required by local code) closed cell insulation.

Slide tubing insulation onto the vapor line so that it is covered completely from the indoor coil to the outdoor unit. Be sure that the tubing is capped before sliding on insulation.

It is not necessary to insulate the liquid line.

NOTE: In areas of extreme temperatures and humidity, additional insulation may be required to prevent excessive condensation and loss of capacity.

Do not insulate liquid line and vapor line together. Liquid line should not be in contact with the vapor line. See Figure 2.

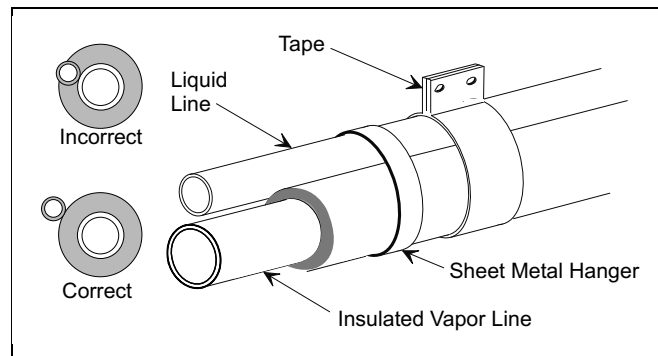

FIGURE 2 : INSULATION OF VAPOR LINE

RE-ASSEMBLING, BRAZING AND CLEANING OF JOINT CONNECTIONS

CAUTION

When using hard solder, an inert gas such as dry nitrogen must be introduced and permitted to flow through tubing during brazing to displace air and prevent oxidation.

Remove the Schrader Valve cores from the service valves. Remove the plugs from the service valve field tubing connections. Clean the joints to be brazed.

NOTE: Do not overheat the connection to be brazed as this can cause improper flow of solder, resulting in a weak and leaking joint. Never apply heat directly to face of fitting. Do not heat solder by direct contact with flame of the torch.

When brazing copper tubing it is very important to preheat the entire joint before applying the solder. This is done by sweeping the flame steadily and evenly around the fitting, to bring both fitting and tubing up to equal temperature before applying the solder.

Reassemble groups of tubing and fittings, brazing several joints instead of one joint at a time. This reduces the chance for error in the alignment of the assembly. Replace Schrader Valve cores. **DO NOT OPEN SERVICE VALVES AT THIS TIME.**

Clean joint connection immediately after brazing with wet rag.

REFRIGERANT LINE SUPPORT

Refrigerant lines should be supported in a way that no dips or sags occur. We recommend four feet between supports. If refrigerant lines are to be attached to the home structure, care should be taken to eliminate the transmission of vibrations. Attach the refrigerant lines to the indoor coil first. Remove plugs from the indoor coil, then clean joints to be brazed. Braze refrigerant lines to the indoor coil. Attach refrigerant lines to the outdoor unit.

CHARGING AND LEAK TESTING

On systems with or without service valves the refrigerant should be recovered or recycled in accordance with EPA regulations. In some cases this may require putting piercing valves on both the high and low sides of the system.

▲ WARNING

DO NOT vent refrigerant to the outdoors.

When recovering refrigerant from a system, with a burnout, follow a safe procedure due to possible contamination.

▲ CAUTION

Avoid getting the refrigerant in the eyes or on the skin.

Contaminated refrigerant must be recovered and returned to the local refrigeration supply house for proper disposition.

TOTAL LINE LENGTH

Units should be installed only with approved system combination (indoor/outdoor) as specified in the Technical Guide.

For systems with total line length exceeding 50 feet, see APPLICATION DATA and work sheet "General Piping Recommendations and Refrigerant Line Length" for vapor and liquid line sizing, calibration of liquid line pressure loss or gain, determination of vapor line velocity, elevation limitations, orifice connections, system charging, traps, etc.

Systems with liquid line pressure loss or gain greater than 11 psi must be provided with corrected orifice size as noted in APPLICATION DATA.

ORIFICE SELECTION (ON SWEAT FIT COILS)

NOTE: The proper orifice must be installed in the indoor coil liquid line connection prior to the connection of the refrigerant lines.

▲ WARNING

Coil is under 30 to 35 psig (inert gas) pressure.

Each coil has an orifice installed in the fitting between the liquid line connection and distributor. The orifice is identified on a label next to the liquid line connection.

The orifice shipped with the outdoor unit is based on the "most sold" combination, but it may be changed, depending on the capacity and efficiency of the outdoor unit, elevation differences, and/or long total line lengths. An additional orifice(s) is shipped with most outdoor units for the most commonly required replacement combinations. Other sizes must be ordered from Source 1 Parts if required.

See the appropriate Tabular Data Sheet for the correct orifice size and charge adder. If the orifice size matches, nothing further is required and the refrigerant lines may be connected per the outdoor unit instruction. However, if another orifice should be used, see the coil instruction for details to change the orifice in the coil.

REFRIGERANT VALVE OPERATION

▲ WARNING

All outdoor units are shipped with the service valves in the closed position. After installation of the refrigerant and proper evacuation, make sure that all valves are in the open position and that the caps are securely tightened before turning ON the electrical power to the outdoor unit.

All models in this series have brass service valves. These valves are not back seating. Opening or closing valve does not close service port. Service ports have Schrader valves for gauge connections. Use back-up wrench on valve body when removing cap to open or close the valve. To open, insert hex wrench into stem and back out counter clockwise until stem just touches retaining ring.

▲ CAUTION

If the valve stem is backed out beyond the retaining ring, system pressure could force the stem out of the valve body and possibly cause personal injury. In the event that the retaining ring is missing do not attempt to open the valve.

Some units may have factory installed 1-1/8" ball valves. To open the valve, remove the brass valve stem cap, located on the side of the valve, with an adjustable wrench. Next, turn the valve stem 1/4 turn CCW (away from unit).

All caps must be replaced to prevent leaks.

Replace valve cap finger tight, then tighten an additional 1/6 of a turn with a wrench, using a back-up wrench on the valve body.

REFRIGERANT LINE (QUICK CONNECT UNITS)

IMPORTANT - Do not remove protective caps from couplings until precharged lines are routed and ready for final connection. Protective caps prevent dirt from entering couplings and contaminating system when connected together.

1. Check size and length of precharged refrigerant lines before installing.
 - a. Check the size of the precharged refrigerant lines to insure that they are correct for the model being installed.
 - b. Check the final routing of the tubing, and insure tubing will be of adequate length, with allowance for connection at the coil and outdoor unit.
2. Copper tubing will work-harden.
 - a. The precharged tubing should be handled carefully.
 - b. Do not bend or work the tubing any more than necessary. (The larger size tubing 3/4" for example, will work-harden rapidly as it is formed. As the tubing becomes harder, it is more susceptible to kinking and damage).

3. Forming Copper.
 - a. No attempt should be made to bend the suction line in a shorter radius than 12". See Figure 3.

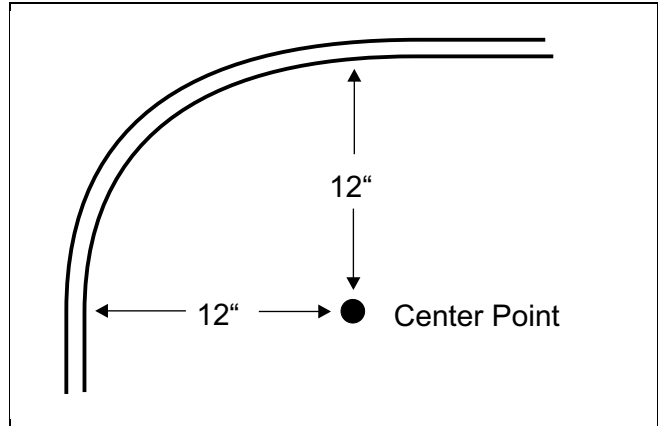

FIGURE 3 : MINIMUM SUCTION LINE FORM

4. How to dispose of excess tubing.
 - a. Tubing may be longer than required. Coil excess tubing nearer the indoor coil rather than the outdoor unit.
 - b. Excess tubing must be coiled horizontally so the flow of refrigerant is from top to bottom of the coil and toward the outdoor unit. Another method is to form a horizontal "U" large enough to take care of excess. See Figure 5.

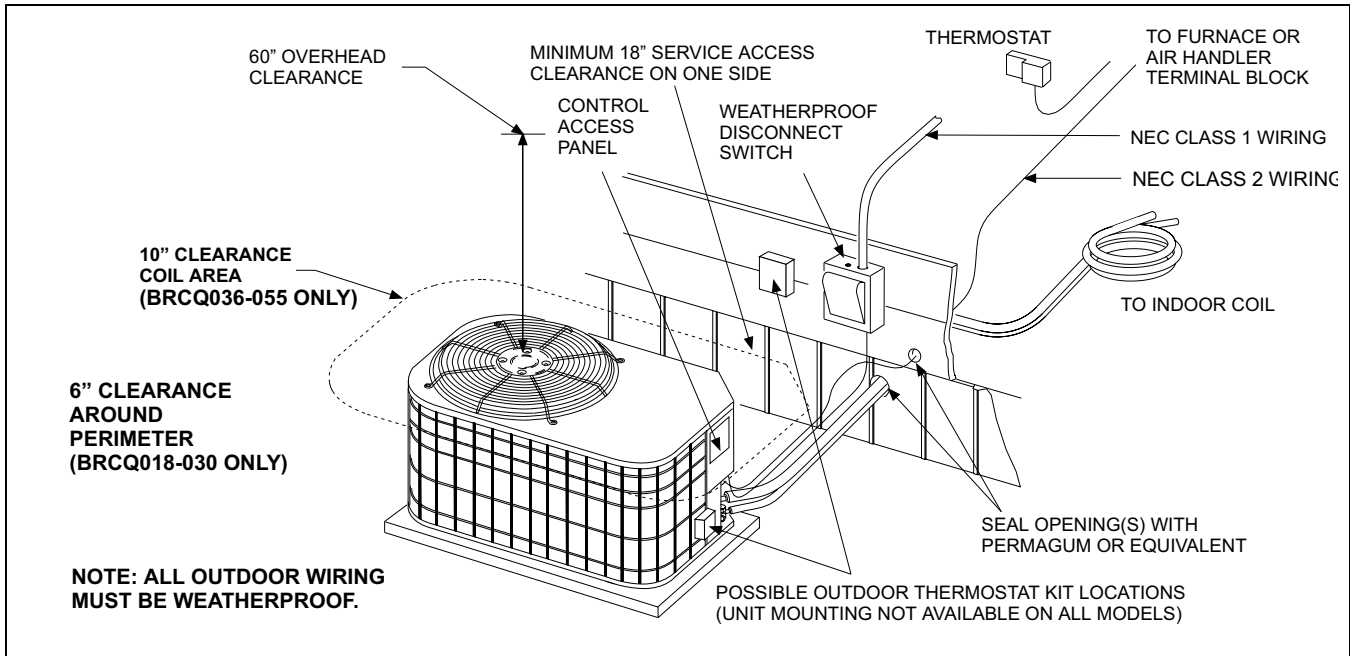

FIGURE 4 : TYPICAL MANUFACTURED HOME APPLICATION

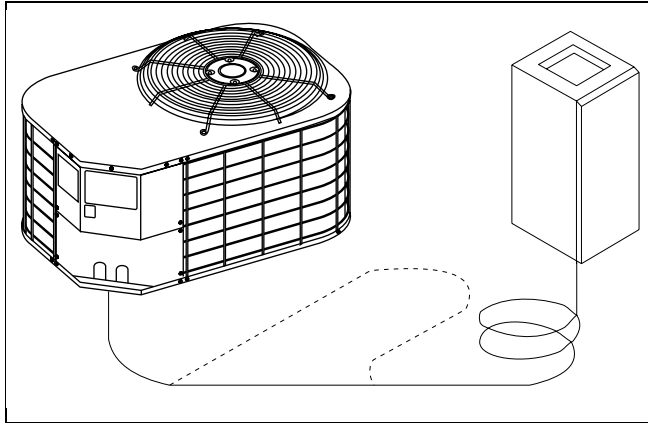

FIGURE 5 : EXCESS TUBE

5. Slope tubing toward outdoor unit.
 - a. When the coil is above the outdoor unit, the suction line should be sloped with a fall of a least 1/4" per feet toward the outdoor unit.
 - b. When the outdoor unit is above the coil, the tubing should be sloped downward along lateral distance to the bottom, or from the vertical riser.
6. Insulation of suction line.
 - a. Standard suction lines come pre-insulated from the factory with 3/8" closed cell insulation, adequate for average installations.

- NOTE:** In regions of extreme temperatures and humidity, additional insulation may be required to prevent excessive condensation and serious loss of capacity.
- b. Do not insulate liquid and suction lines together.
 - c. Liquid lines should not be insulated.
 - d. Liquid lines should not be in bare contact with suction line. See Figure 2.

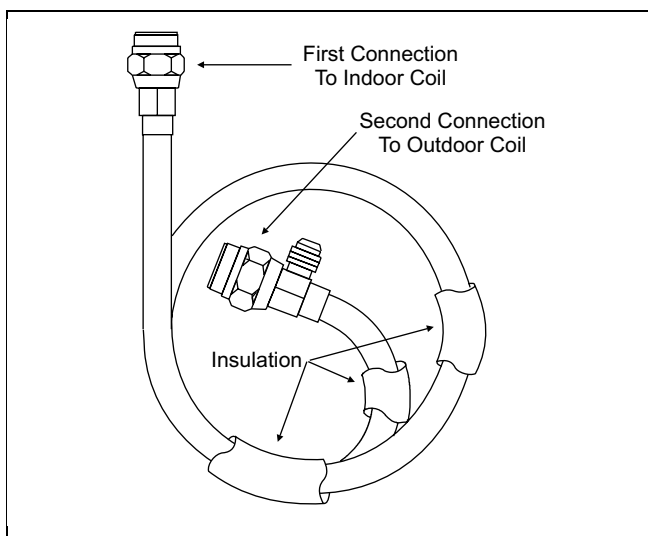

FIGURE 6 : QUICK CONNENT REFRIGERANT LINE

▲ WARNING

Liquid refrigerant under pressure. Liquid refrigerant can cause severe frostbite. To avoid possible loss of sight and/or frostbite use eye protection (safety glasses or safety face shield). Wearing leather gloves will offer protection to hands.

7. Install refrigerant lines to indoor coil first. (The couplings without Schrader valves are to be connected to the indoor coil. See Figure 7.
 - a. Form the tubing so it is properly aligned with the connections on the coil.
 - b. Remove plugs and caps from connections.
 - c. Check that the rubber seals in connection ends are intact.
 - d. Be sure surfaces are clean.
 - e. Lubricate the rubber seals with clean refrigerant oil and make connections.
 - f. Thread couplings together by hand to be sure they are not cross threaded. Tighten coupling so diaphragms are touching. (Do not puncture diaphragms at this time).
8. Install refrigerant line to outdoor unit. (The couplings with Schrader valves are to be connected to the outdoor unit.
 - a. Form the tubing so it is properly aligned with the connections on the outdoor unit. Insure the Schrader valves are accessible.
 - b. Remove plugs and caps from connections.
 - c. Check that the rubber seals in connection ends are intact.
 - d. Be sure surfaces are clean.
 - e. Lubricate the rubber seals with clean refrigerant oil and make connections.
 - f. Thread couplings together by hand to be sure they are not cross threaded. Tighten coupling so diaphragms are touching. (Do not puncture diaphragms at this time).
9. Tightening couplings.
 - a. Tighten indoor coil couplings with wrenches; using wrench on stationary fitting of coupling and liquid line fitting at coil while nut is being tightened. See Figure 7. Tighten the nut until the coupling bottoms out.
 - b. Then tighten an additional 1/6 turn to complete the knife edge seal.
 - c. Tighten outdoor unit couplings, with wrenches using a wrench on the stationary fitting of the coupling while nut is being tightened. Tighten the nut until the coupling bottoms out.
 - d. Then tighten an additional 1/6 turn to complete the knife edge seal.

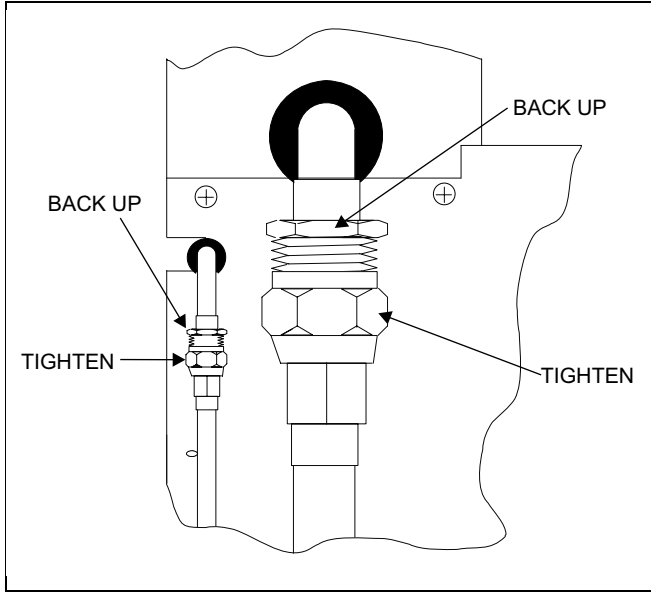

FIGURE 7 : QUICK CONNECT COUPLING

10. Check for leaks.
 - a. After the line set connections have been made they should be checked for leaks.
 - b. If the valves were kept clean and lubricated per instruction no leaks should be found.
 - c. Use leak detect solution or soap solution for leak testing. An electronic leak detector is recommended.

OIL TRAPPING

When the outdoor unit is above the indoor coil oil trapping is necessary. An oil trap should be provided for every 20 feet of rise..

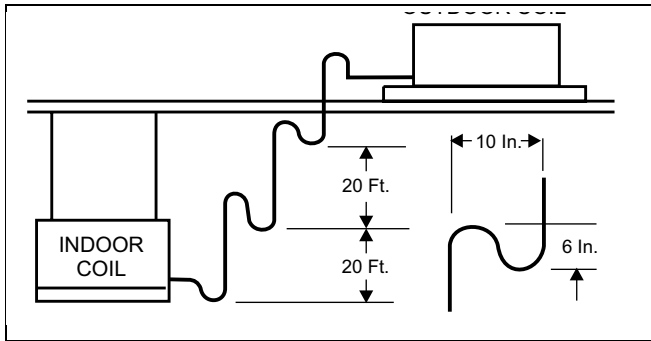

FIGURE 8 : OIL TRAP

Check the system for correct charge after all components of the system have been installed, connected and wired correctly.

Connect service gauges to low pressure port and discharge service ports.

Allow unit to operate until system pressures and temperatures have stabilized, making sure that the pressure and temperature align with unit service data. If not, check system charge and adjust if necessary.

ELECTRICAL WIRING

⚠ WARNING

To prevent electrical shock, open remote disconnect so electrical supply to outdoor unit is shut off. Contactor does not open both sides of the 208/230 volt electrical circuit.

POWER SUPPLY

All wiring must comply with N.E.C. and local codes. See rating plate and product data sheet for volts, frequency, phase, maximum fuse size and minimum branch circuit ampacity.

Refer to the wiring diagram inside the unit control box cover before connecting to power supply.

1. The 208/230 volt single phase line voltage service wiring for the outdoor unit must include a disconnect switch located within sight of the outdoor unit.
2. Use the correct size fuse or circuit breaker as listed on the unit rating plate and data sheet. If using nonmetallic-sheathed cable (NM or NM-B) ampacities shall be that of 60° C conductors per N.E.C 336-26.
3. Wiring connections. - Two are provided in the control box:
 - a. One for low voltage wiring.
 - b. One entrance for high voltage L1 and L2.

The adjustable High Voltage Conduit Plate is factory installed for 1/2" conduit connections. For 3/4" conduit, remove the screw holding the plate in place and adjust the location of the holes. For 1" conduit, remove the conduit plate and discard. Re-install screw to maintain the integrity of the unit structure, regardless of the conduit being used. See Figures 9, 10 & 11.

4. Power connection to the unit is facilitated by screw terminals, L1 and L2 on the outdoor unit contactor. See Figures 9, 10 & 11.
5. Ground the outdoor unit using the ground lug provided. Unless the outdoor unit is grounded through proper wiring to the service entrance ground, a suitable separate ground should be provided at the outdoor unit.
6. Use copper conductors only.

⚠ CAUTION

Casing or cabinet must be permanently grounded in accordance with National Electric Code or other applicable local codes.

LOW VOLTAGE

Control wiring may vary depending upon the type of thermostat and furnace being connected.

Low voltage wiring diagrams can be found with the furnace or air conditioning blower package installation instructions.

Pig-tail connector wires (2 blue or 1 blue, 1 brown) are provided from the low voltage pull-in coil on the contactor to a section of the control box (See Figure 12). A "Fingered" bushing is provided in the low voltage knockout hole. If 1/2" conduit is used for the low voltage wiring, the bushing is to be removed.

1. Route the low voltage cable through the fingered bushing in the low voltage junction box. See Figures 9, 10 & 11.
2. Using wire nuts, connect the low voltage wiring within the low voltage box.
3. A minimum of 19 AWG wire must be used in connecting the low voltage control wiring between the outdoor unit, air handler thermostat, and outdoor thermostat.

Connect thermostat and control package wiring as shown in Figure 12 and per the instructions packed with those pieces.

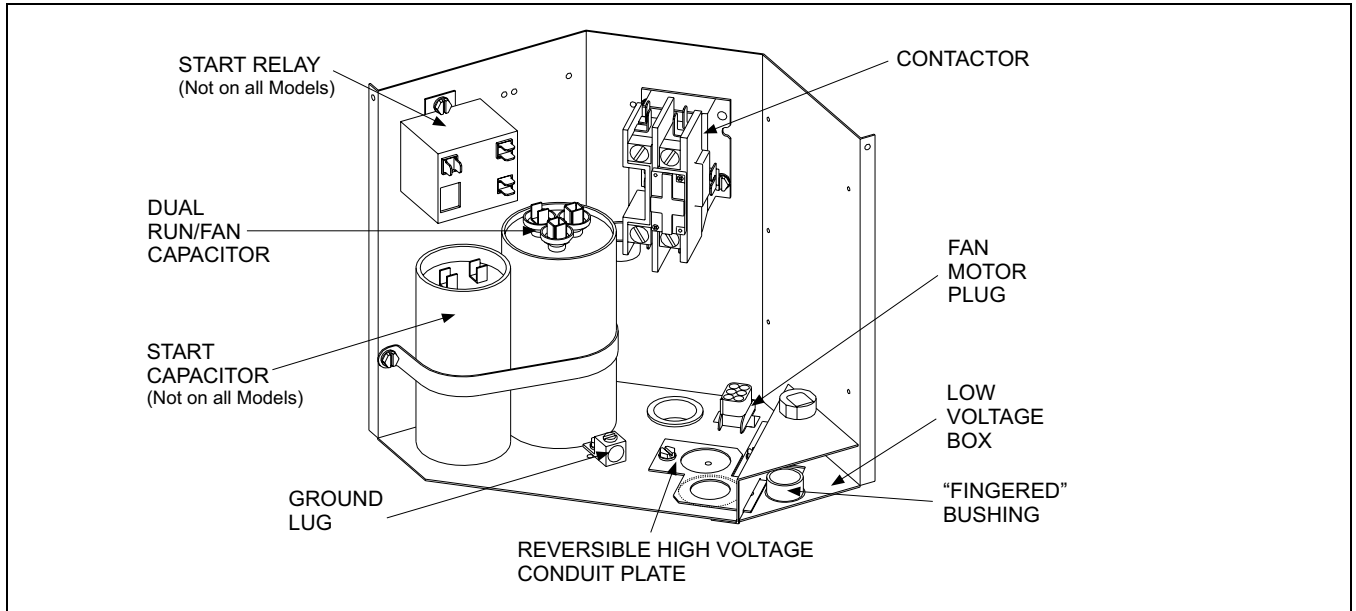

FIGURE 9 : OUTDOOR UNIT CONTROL BOX (10 & 12 SEER) (START COMPONENTS SHOWN)

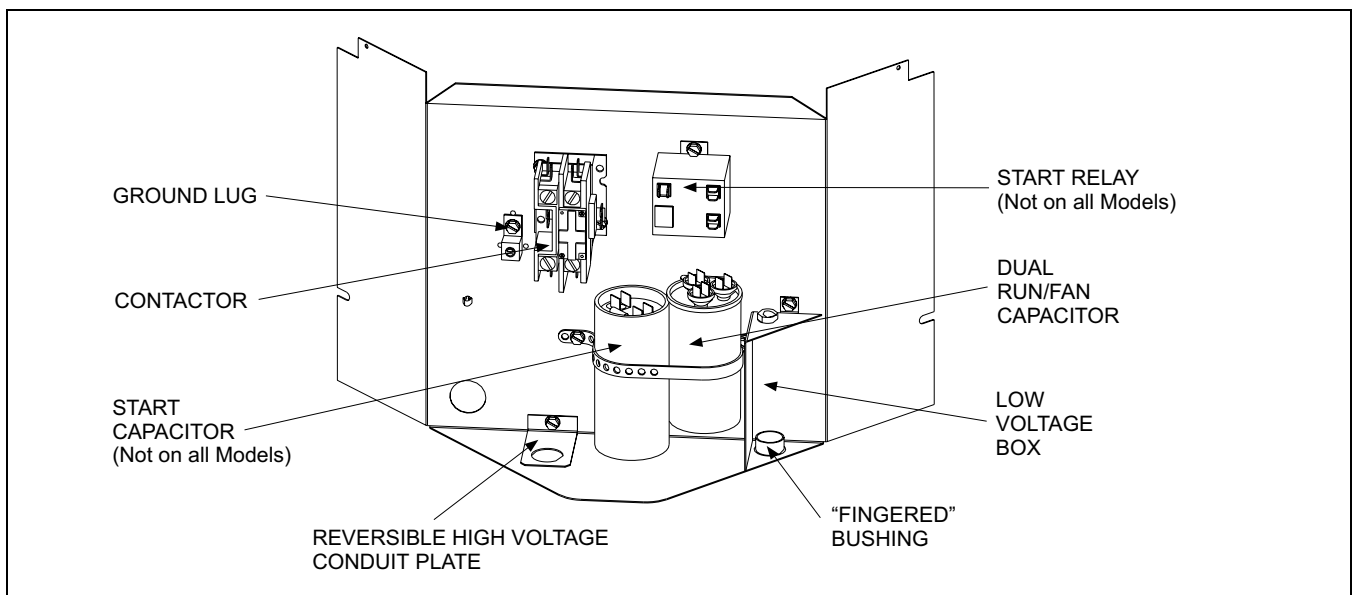

FIGURE 10 : OUTDOOR UNIT CONTROL BOX (BRCQ018-030) (10 SEER)

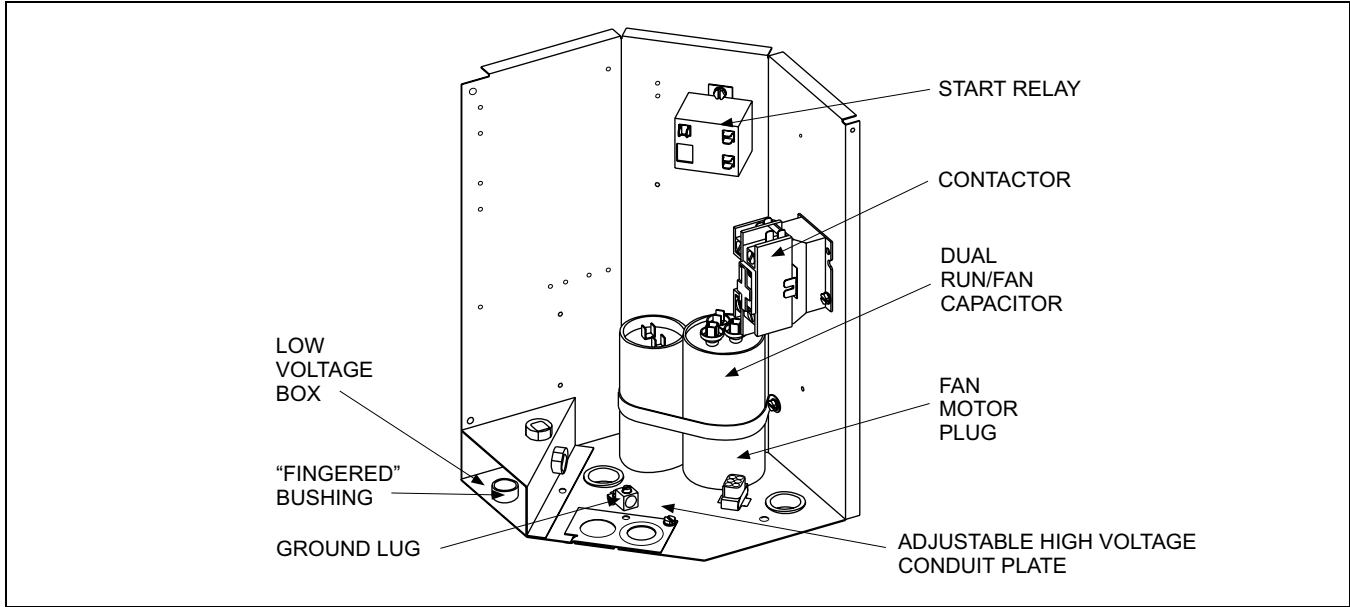

FIGURE 11 : OUTDOOR UNIT CONTROL BOX (14 SEER) (START COMPONENTS SHOWN)

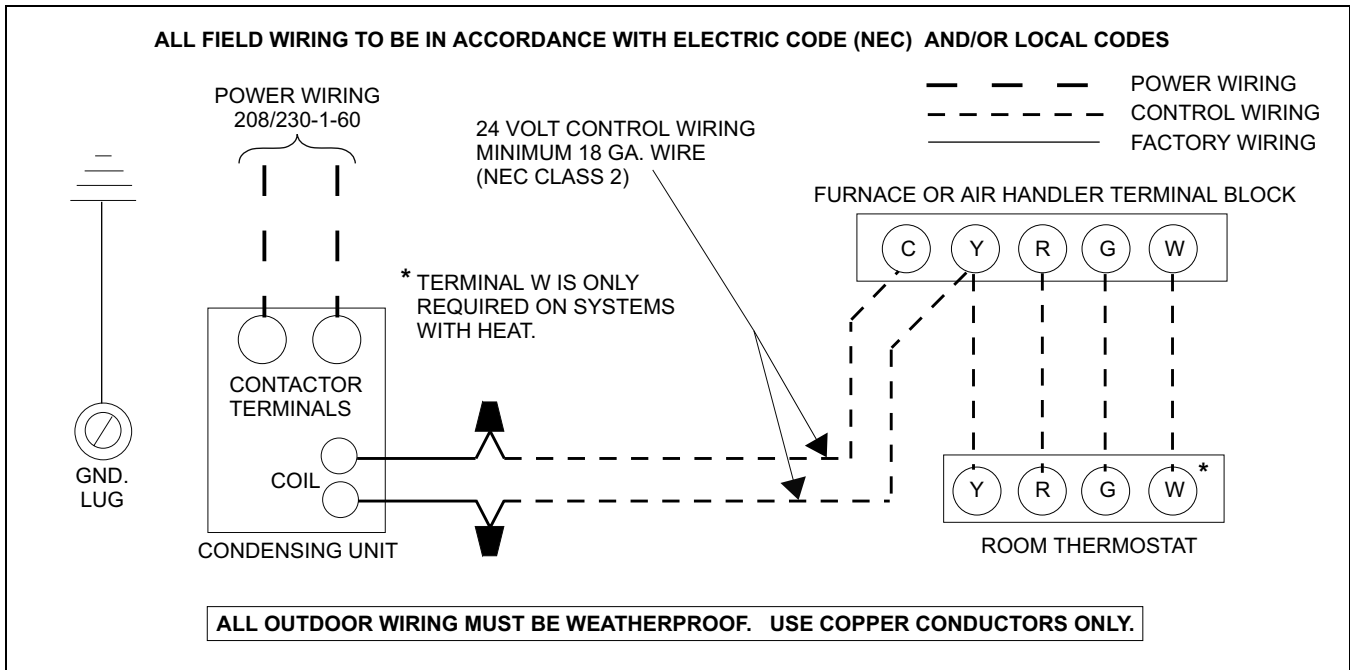

FIGURE 12 : TYPICAL FIELD WIRING

CHECKOUT PROCEDURE

Use the following list to see that nothing was over looked:

1. Have all braze joints on refrigerant lines been leak checked? (Sweat Fit Units)
2. Line set fittings leak checked? (Quick Connect Units)
3. Have base valves been opened? (Sweat Fit Units only)
4. Have all refrigerant lines been secured and isolated properly?
5. Is the indoor coil drain hooked up and draining freely? Pour water in drain pan.
6. Is air filter installed and clean?

IMPORTANT - Installer should place unit data sheet and installation instructions in customer packet and give to home owner after installation is complete.

SYSTEM OPERATION CHECKOUT

1. With thermostat set to the OFF position, close disconnect switch or switches to complete circuits to condensing unit and furnace. Set thermostat to call for cooling.
2. After the system starts, check the voltage and amperage at the condensing unit contactor.
3. If voltage is not within 10% of rated voltage, or amperage greatly exceeds nameplate amperage, shut down the system and contact the local power company for corrections; otherwise unsatisfactory performance may result.
4. With the system in operation, check the condensing unit for unusual noise and undue vibration.
5. Allow the system to operate until it is balanced or stabilized (approximately 30 minutes), before making further checks.
6. Remove manifold gages hoses, and install cap on Schrader valves.

NOTES

Unitary	5005	Norman
Product	York	OK
Group	Drive	73069