

INSTALLATION MANUAL

HIGH EFFICIENCY CLAM TUBE HEAT EXCHANGER SERIES

MODELS: G8C/GF8

(Single Stage Multi-Position)

50 - 150 MBH INPUT
(14.65 - 44.00 KW) INPUT



TABLE OF CONTENTS

SAFETY	1	ACCESSORY CONNECTIONS	14
DUCTWORK	4	TWINNING AND STAGING	14
FILTERS	9	VENT/COMBUSTION AIR SYSTEM	16
GAS PIPING	11	SAFETY CONTROLS	22
ELECTRICAL POWER	13	START-UP AND ADJUSTMENTS	22

LIST OF FIGURES

Upflow/Horizontal Configuration	5	Accessory Connections	14
Downflow/Horizontal Configuration	5	Typical Twinned Furnace Application	15
Vent Blower	5	Single Stage Twinning Wiring Diagram	15
Top Cap	6	Two-Stage Twinning Wiring Diagram	16
Dimensions	7	Vent Termination	16
Combustible Floor Base Accessory	8	Vent Termination	16
Typical Attic Installation	9	Alternate Air Intake, Air Outlet and Chimney Connections	17
Typical Suspended Furnace / Crawl Space Installation	9	Air Inlet, Outlet and Chimney Connections	17
Side Return Cutout Markings	10	Typical Sidewall Vent Application	18
Horizontal Mount and Filter	10	Typical Sidewall Vent and Termination Configuration	18
Downflow Filter	10	Typical Chimney Connections	18
Return Filter Grill and Return Duct Installation	11	Horizontal Air Inlet, Outlet and Chimney Connections	18
Gas Valve	11	Home Layout	19
Upflow Configuration (50-125 MBH Model Only)	12	Combustion Airflow Path Through The Furnace	20
Downflow Configuration (50-125 MBH Model Only)	12	Casing to the Burner Box	20
Upflow/Horizontal Configuration (150 MBH Model Only)	12	Outside and Ambient Combustion Air	21
Gas Piping	12	Pressure Switch Tubing Routing	22
Electrical Wiring - Upflow Position	14	Gas Valve	25
Line Wiring Connections	14	Reading Gas Pressure	25
Two-Stage Heating and Cooling Thermostat Connections	14	Typical Heat/Cool Speed Tap Connections	26
		Wiring Diagram	28

LIST OF TABLES

Unit Clearances to Combustibles	4	Horizontal Sidewall Venting Clearances	18
Minimum Duct Sizing For Proper Airflow	6	Estimated Free Area	20
External Static Pressure Range	6	Free Area	20
Cabinet and Duct Dimensions	7	Unconfined Space Minimum Area in Square Feet	20
Filter Sizes - Upflow	10	Field Installed Accessories - Non Electrical	23
Inlet Gas Pressure Range	12	Inlet Gas Pressure Range	25
High Altitude Conversion	13	Nominal Manifold Pressure	25
Ratings & Physical / Electrical Data - Upflow Models	13	Filter Performance - Pressure Drop Inches W.C. and (kPa)	26
Roof Pitch	16	Blower Performance - CFM	27

SECTION I: SAFETY



This is a safety alert symbol. When you see this symbol on labels or in manuals, be alert to the potential for personal injury.

Understand and pay particular attention to the signal words **DANGER**, **WARNING**, or **CAUTION**.

DANGER indicates an **imminently** hazardous situation, which, if not avoided, **will result in death or serious injury**.

WARNING indicates a **potentially** hazardous situation, which, if not avoided, **could result in death or serious injury**.

CAUTION indicates a potentially hazardous situation, which, if not avoided **may result in minor or moderate injury**. It is also used to alert against unsafe practices and hazards involving only property damage.

WARNING

Improper installation may create a condition where the operation of the product could cause personal injury or property damage. Improper installation, adjustment, alteration, service or maintenance can cause injury or property damage. Refer to this manual for assistance or for additional information, consult a qualified contractor, installer or service agency.

CAUTION

This product must be installed in strict compliance with the installation instructions and any applicable local, state, and national codes including, but not limited to building, electrical, and mechanical codes.

SPECIFIC SAFETY RULES AND PRECAUTIONS

1. Only Natural gas or Propane (LP) gas are approved for use with this furnace. Refer to the furnace rating plate or Section IV of these instructions.
2. Install this furnace only in a location and position as specified in SECTION I of these instructions.
3. A gas-fired furnace for installation in a residential garage must be installed as specified in SECTION I of these instructions.
4. Provide adequate combustion and ventilation air to the furnace space as specified in SECTION VII of these instructions.
5. Combustion products must be discharged outdoors. Connect this furnace to an approved vent system only, as specified in SECTION VII of these instructions.

WARNING

FIRE OR EXPLOSION HAZARD

Failure to follow the safety warnings exactly could result in serious injury, death or property damage.

Never test for gas leaks with an open flame. Use a commercially available soap solution made specifically for detection of leaks to check all connections. A fire or explosion may result causing property damage, personal injury or loss of life.

6. Test for gas leaks as specified in SECTION XI of these instructions.
7. Always install the furnace to operate within the furnace's intended temperature rise range. Only connect the furnace to a duct system which has an external static pressure within the allowable range, as specified on the furnace rating plate.
8. When a furnace is installed so that supply ducts carry air circulated by the furnace to areas outside the space containing the furnace, the return air shall also be handled by duct(s) sealed to the furnace casing and terminating outside the space containing the furnace.
9. It is permitted to be use the furnace for heating of buildings or structures under construction. Installation must comply with all manufacturer's installation instructions including:
 - Proper vent installation;
 - Furnace operating under thermostatic control;
 - Return air duct sealed to the furnace;
 - Air filters in place;
 - Set furnace input rate and temperature rise per rating plate marking;
 - Means for providing outdoor air required for combustion;
 - Return air temperature maintained between 55°F (13°C) and 80°F (27°C);
 - The **air filter must be replaced** upon substantial completion of the construction process;
 - Clean furnace, duct work and components upon substantial completion of the construction process, and verify furnace-operating conditions including ignition, input rate, temperature rise and venting, according to the manufacturer's instructions.

The following requirements to be met:

- a. Clean, outside combustion air is provided to the furnace to minimize the impact of corrosive adhesives, sealants, and other construction materials. Drywall dust is a major concern during construction, which can be pulled into the combustion air path, leading to plugged gas valves, burners, and inducer assemblies.
- b. Filter must be installed in the furnace as specified in the installation instructions, and must be replaced or thoroughly cleaned prior to occupancy of the home. Again, drywall dust is the key issue, as that dust can be pulled into the circulating blower motor, plugging the motor vents, coating the rotors and stators, etc. which can lead to a potential fire hazard.

- c. The temperature of the return air to the furnace must not be less than 55 degrees F (13 deg C), with no evening setback or furnace shutdown, to prevent condensation in the primary heat exchangers.
 - d. The air temperature rise must be within the stated rise range as indicated on the furnace rating plate, and the firing input rate must be set to the unit nameplate value.
 - e. The external static pressure of the air distribution system ductwork must at set for heating operation to be at least 0.10 to 0.20 inches water column, based on the input rate of the furnace, with the lower value for input rates less than 55,000 btu/hr and the upper value for units with input rates above 100,000 btu/hr.
 - f. A return air duct must be used, sealed to the furnace cabinet, and terminated outside the space where the furnace is installed. This prevents any recirculation of supply air, which can generate a negative pressure condition at the furnace for non-direct vent furnaces, leading to possible flame rollout or combustion problems.
 - g. The furnace and ductwork should be thoroughly and completely cleaned prior to occupancy of the dwelling to insure the proper operation of the furnace and to avoid potential health concerns.
10. When installed in a Non-HUD-Approved Modular Home or building constructed on-site, combustion air shall not be supplied from occupied spaces.
 11. The size of the unit should be based on an acceptable heat loss calculation for the structure. ACCA, Manual J or other approved methods may be used.

SAFETY REQUIREMENTS

- This furnace should be installed in accordance with all national and local building/safety codes and requirements, local plumbing or wastewater codes, and other applicable codes. In the absence of local codes, install in accordance with the National Fuel Gas Code ANSI Z223.1/NFPA 54, National Fuel Gas Code, and/or CAN/CGA B149.1 Natural Gas and Propane Installation Code (latest editions). Furnaces have been certified to the latest edition of standard ANSI Z21-47 • CSA 2.3.
- Refer to the unit rating plate for the furnace model number, and then see the dimensions page of this instruction for return air plenum dimensions in Figure 5. The plenum must be installed according to the instructions.
- Provide clearances from combustible materials as listed under Clearances to Combustibles.
- Provide clearances for servicing ensuring that service access is allowed for both the burners and blower.
- These models **ARE NOT** CSA listed or approved for installation into a **HUD Approved Modular Home** or a **Manufactured (Mobile) Home**.
- This furnace is not approved for installation in trailers or recreational vehicles.
- **Failure to carefully read and follow all instructions in this manual can result in furnace malfunction, death, personal injury and/or property damage.**
- Furnaces for installation on combustible flooring shall not be installed directly on carpeting, tile or other combustible material other than wood flooring.
- Check the rating plate and power supply to be sure that the electrical characteristics match. All models use nominal 115 VAC, 1 Phase, 60-Hertz power supply. **DO NOT CONNECT THIS APPLIANCE TO A 50 HZ POWER SUPPLY OR A VOLTAGE ABOVE 130 VOLTS.**

- Furnace shall be installed so the electrical components are protected from water.
- Installing and servicing heating equipment can be hazardous due to the electrical components and the gas fired components. Only trained and qualified personnel should install, repair, or service gas heating equipment. Untrained service personnel can perform basic maintenance functions such as cleaning and replacing the air filters. When working on heating equipment, observe precautions in the manuals and on the labels attached to the unit and other safety precautions that may apply.
- These instructions cover minimum requirements and conform to existing national standards and safety codes. In some instances these instructions exceed certain local codes and ordinances, especially those who have not kept up with changing residential and non-HUD modular home construction practices. These instructions are required as a minimum for a safe installation.

COMBUSTION AIR QUALITY (LIST OF CONTAMINANTS)

The furnace will require **OUTDOOR AIR** for combustion when the furnace is located in any of the following environments.

- Restricted Environments
- Commercial buildings
- Buildings with indoor pools
- Furnaces installed in laundry rooms
- Furnaces installed in hobby or craft rooms
- Furnaces installed near chemical storage areas
- Chemical Exposure

The furnace will require **OUTDOOR AIR** for combustion when the furnace is located in an area where the furnace is being exposed to the following substances and / or chemicals.

- Permanent wave solutions
- Chlorinated waxes and cleaners
- Chlorine based swimming pool chemicals
- Water softening chemicals
- De-icing salts or chemicals
- Carbon tetrachloride
- Halogen type refrigerants
- Cleaning solvents (such as perchloroethylene)
- Printing inks, paint removers, varnishes, etc.
- Hydrochloric acid
- Cements and glues
- Antistatic fabric softeners for clothes dryers
- Masonry acid washing materials

If outdoor air is used for combustion, the combustion air intake duct system termination must be located external to the building and in an area where there will be no exposure to the substances listed above.

▲ WARNING

The furnace area must not be used as a broom closet or for any other storage purposes, as a fire hazard may be created. Never store items such as the following on, near or in contact with the furnace.

1. Spray or aerosol cans, rags, brooms, dust mops, vacuum cleaners or other cleaning tools.
2. Soap powders, bleaches, waxes or other cleaning compounds; plastic items or containers; gasoline, kerosene, cigarette lighter fluid, dry cleaning fluids or other volatile fluid.
3. Paint thinners and other painting compounds.
4. Paper bags, boxes or other paper products

Never operate the furnace with the blower door removed. To do so could result in serious personal injury and/or equipment damage.

INSPECTION

As soon as a unit is received, it should be inspected for possible damage during transit. If damage is evident, the extent of the damage should be noted on the carrier's freight bill. A separate request for inspection by the carrier's agent should be made in writing. Also, before installation the unit should be checked for screws or bolts, which may have loosened in transit, and any shipping or spacer brackets which need to be removed.

FURNACE LOCATION AND CLEARANCES

The furnace shall be located using the following guidelines:

1. Where a minimum amount of air intake/vent piping and elbows will be required.
2. As centralized with the air distribution as possible.
3. Where adequate combustion air will be available (particularly when the appliance is not using outdoor combustion air).
4. Where it will not interfere with proper air circulation in the confined space.
5. Where the outdoor vent terminal will not be blocked or restricted. Refer to "VENT CLEARANCES" located in SECTION VII of these instructions. These minimum clearances must be maintained in the installation.
6. Where the unit will be installed in a level position with no more than 1/4" (0.64 cm) slope side-to-side and front-to-back to provide proper condensate drainage.

Installation in freezing temperatures:

1. Furnace shall be installed in an area where ventilation facilities provide for safe limits of ambient temperature under normal operating conditions. Ambient temperatures falling below 32° F (0° C) may result in the flue temperature falling below 260° F (127° C) at any point in the flue pipe between the furnace and the chimney or a B-Vent. The flue products will condense in the vent pipe if the flue temperature falls below 260° F (127° C) causing the vent pipe to deteriorate rapidly.
2. Do not allow return air temperature to be below 55° F (13° C) for extended periods. To do so may cause condensation to occur in the main heat exchanger, leading to premature heat exchanger failure.

▲ WARNING

Improper installation in an ambient below 32°F (0.0° C) could create a hazard, resulting in damage, injury or death.

3. If this furnace is installed in an unconditioned space and an extended power failure occurs, there will be potential damage to the internal components. Following a power failure situation, do not operate the unit until inspection and repairs are performed.

Clearances for access:

Ample clearances should be provided to permit easy access to the unit. The following minimum clearances are recommended:

1. Twenty-four (24) inches (61 cm) between the front of the furnace and an adjacent wall or another appliance, when access is required for servicing and cleaning.
2. Eighteen (18) inches (46 cm) at the side where access is required for passage to the front when servicing or for inspection or replacement of flue/vent connections.

In all cases, accessibility clearances shall take precedence over clearances for combustible materials where accessibility clearances are greater.

WARNING

Downflow furnaces for installation on combustible flooring only when installed on the accessory combustible floor base on wood flooring only and shall not be installed directly on carpeting, tile or other combustible material.

Check the rating plate and power supply to be sure that the electrical characteristics match. All models use nominal 115 VAC, 1 Phase 60Hz power supply.

Furnace shall be installed so the electrical components are protected from water.

Installation in a residential garage:

A gas-fired furnace for installation in a residential garage must be installed so the burner(s) and the ignition source are located not less than (18) inches (46 cm) above the floor, and the furnace must be located or protected to avoid physical damage by vehicles.

TABLE 1: Unit Clearances to Combustibles

APPLICATION	TOP	FRONT	REAR	SIDES	SINGLE WALL VENT	FLOOR/ BOTTOM	CLOSET	ALCOVE	ATTIC	LINE CONTACT
	In. (cm)	In. (cm)	In. (cm)	In. (cm)	In. (cm)					
UPFLOW	1 (25.4)	2 (5.08)	0 (0.0)	0 (0.0)	6 (15.24)	COMBUSTIBLE	YES	YES	YES	NO
UPFLOW B-VENT	1 (25.4)	3 (7.62)	0 (0.0)	0 (0.0)	6 (15.24)	COMBUSTIBLE	YES	YES	YES	NO
HORIZONTAL	1 (25.4)	2 (5.08)	0 (0.0)	1 (5.08)	6 (15.24)	COMBUSTIBLE	NO	YES	YES	YES ¹
HORIZONTAL B-VENT	1 (25.4)	3 (7.62)	0 (0.0)	0 (0.0)	6 (15.24)	COMBUSTIBLE	NO	YES	YES	YES ¹
DOWNFLOW	1 (25.4)	2 (5.08)	0 (0.0)	0 (0.0)	6 (15.24)	NON-COMBUSTIBLE	YES	YES	YES	NO
DOWNFLOW B-VENT	1 (25.4)	3 (7.62)	0 (0.0)	0 (0.0)	6 (15.24)	NON-COMBUSTIBLE	YES	YES	YES	NO

1. Line contact only permitted between lines formed by the intersection of the rear panel and side panel (top in horizontal position) of the furnace jacket and building joists, studs or framing.

SECTION II: DUCTWORK**DUCTWORK GENERAL INFORMATION****The duct system's design and installation must:**

- Handle an air volume appropriate for the served space and within the operating parameters of the furnace specifications.
- Be installed in accordance with standards of NFPA (National Fire Protection Association) as outlined in NFPA pamphlets 90A and 90B (latest editions) or applicable national, provincial, or state, and local fire and safety codes or in Canada, refer to the Natural Gas and Propane Installation Code B149.1-00.
- Create a closed duct system. For residential and Non-HUD Modular Home installations, when a furnace is installed so that the supply ducts carry air circulated by the furnace to areas outside the space containing the furnace, the return air shall also be handled by a duct(s) sealed to the furnace casing and terminating outside the space containing the furnace.
- Complete a path for heated or cooled air to circulate through the air conditioning and heating equipment and to and from the conditioned space.

CAUTION

The cooling coil must be installed in the supply air duct, downstream of the furnace. Cooled air may not be passed over the heat exchanger.

When the furnace is used in conjunction with a cooling coil, the coil must be installed parallel with, or in the supply air side of the furnace to avoid condensation in the primary heat exchanger. When a parallel flow arrangement is used, dampers or other means used to control airflow must be adequate to prevent chilled air from entering the furnace. If manually operated, the damper must be equipped with means to prevent the furnace or the air conditioner from operating unless the damper is in full heat or cool position.

WARNING

The duct system must be properly sized to obtain the correct airflow for the furnace size that is being installed.

Refer to Table 8 and the furnace rating plate for the correct rise range and static pressures

If the ducts are undersized, the result will be high duct static pressures and/or high temperature rises which can result in a heat exchanger OVERHEATING CONDITION. This condition can result in premature heat exchanger failure, which can result in personal injury, property damage, or death.

INSTALLATION POSITION (50-125 MBH Models)

This furnace may be installed in an upflow, downflow or horizontal position. Depending on the configuration shipped from the factory, it may be necessary to convert the furnace from downflow to upflow or from upflow to downflow configuration. Use conversion instructions in this document.

INSTALLATION POSITION (150 MBH Models)

This furnace may be installed in an upflow or horizontal position. No conversion is necessary. This furnace is not approved for downflow application.

CONVERSION INFORMATION (50-125 MBH Models)

This furnace may be shipped in either the upflow or the downflow configuration. To convert from upflow to downflow or vice-versa it is necessary only to exchange the top and bottom casing caps and to rotate the vent blower 180 degrees. Use the step by step instructions to perform the conversion.

TO CONVERT FROM DOWNFLOW TO UPFLOW CONFIGURATION (50-125 MBH Models)

1. Lay the furnace on its back.
2. Remove the front door.
3. Remove the seven sheet metal screws that are used to fasten the top cap to the casing. Remove the top cap and save the screws.
4. Remove the four sheet metal screws that are used to fasten the bottom cap to the casing. Remove the bottom cap and save the screws.
5. Unplug the vent blower wires.
6. Disconnect the pressure hose from the vent blower.
7. Remove the four machine screws that fasten the vent blower to the vent pan and save the screws. Leave the gasket in place on the pan.
8. Remove the two extra machine screws in the vent pan front and save the screws.
9. Rotate the vent blower and transition 180° so that its outlet points to the outlet air end of the furnaces as shown in Figure 1.
10. Line up the vent blower mounting holes with the holes in the vent pan and screw it into place. Use the same machine screws that held the vent blower in place previously.
11. Install the two extra machine screws in the two open holes in the front of the vent pan See Figure 1.
12. Plug in the vent motor wires.
13. Plug the pressure hose into the vent blower.
14. Remove the rectangular knockout in the center of the top cap. See Figure 4.
15. Install the top cap at the same end of the furnace as the vent blower, using the sheet metal screws saved earlier. See Figure 1.
16. Install the bottom cap on the bottom of the furnace using the sheet metal screws saved earlier. See Figure 1.
17. The conversion is now complete. The furnace may now be installed in the upflow position or in the horizontal position on either side.

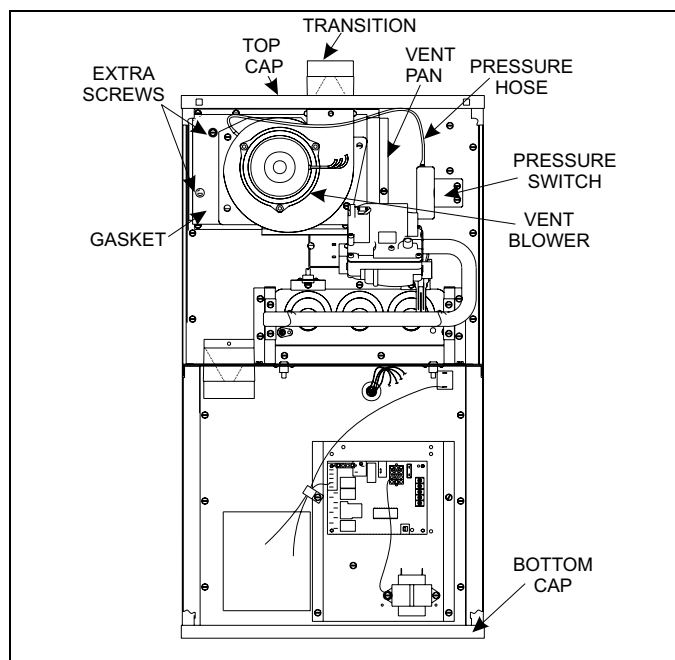

FIGURE 1: Upflow/Horizontal Configuration

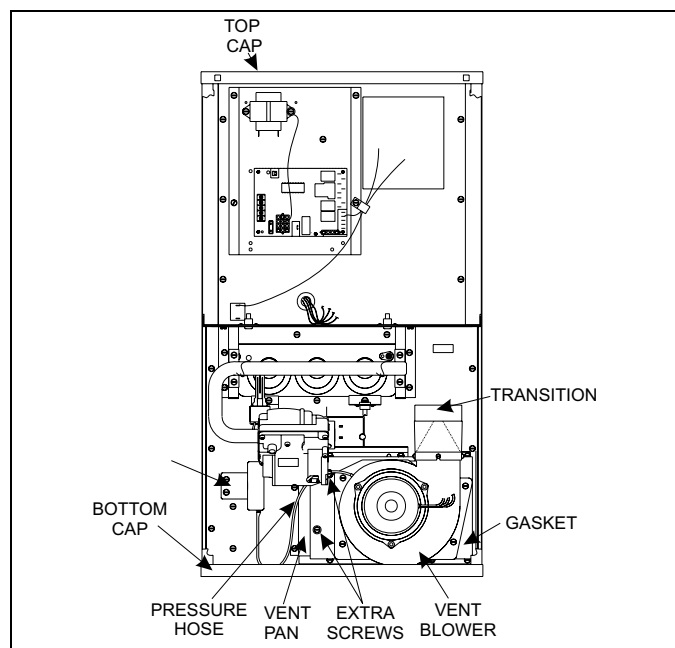

FIGURE 2: Downflow/Horizontal Configuration

TO CONVERT FROM UPFLOW TO DOWNFLOW CONFIGURATION (50-125 MBH Models)

1. Lay the furnace on its back.
2. Remove the front door.
3. Remove the seven sheet metal screws that are used to fasten the top cap to the casing.
4. Remove the four sheet metal screws that are used to fasten the bottom cap to the casing. Remove the bottom cap and save the screws.
5. Unplug the vent blower wires.
6. Disconnect the pressure hose from the vent blower.
7. Remove the four machine screws that fasten the vent blower to the vent pan and save the screws. Leave the gasket in place on the vent pan.
8. Remove the two extra machine screws in the vent pan front and save the screws.
9. Install the cast aluminum transition on the vent blower, using the three screws supplied on the vent blower. See Figure 3.

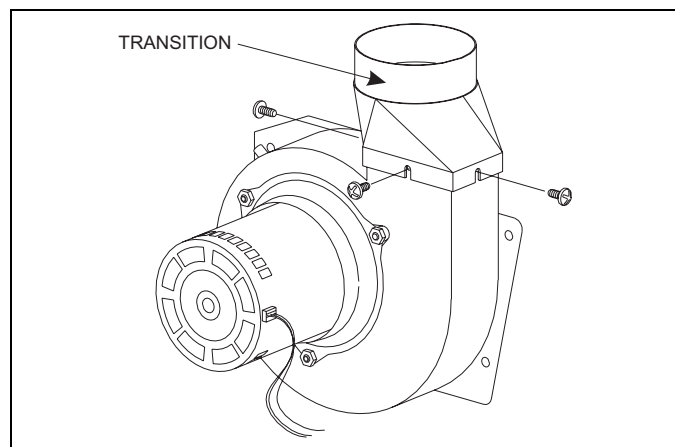

FIGURE 3: Vent Blower

10. Rotate the vent blower 180° so that its outlet points toward the inlet air end of the furnace. See Figure 2.
11. Line up the vent blower mounting holes with the holes in the vent pan and screw it into place. Use the same machine screws that held the vent blower in place previously.
12. Install the two extra machine screws in the two open holes in the front of the vent pan. See Figure 2.
13. Plug in the vent motor wires.
14. Plug the pressure hose into the vent blower.
15. Remove the round knockout at the right side of the top cap. See Figure 4.

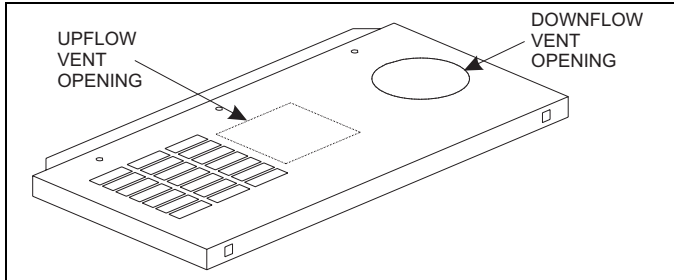

FIGURE 4: Top Cap

16. Install the top cap at the opposite end of furnace from the vent blower, using the seven sheet metal screws saved earlier. See Figure 2.
17. Install the bottom cap on the bottom of the furnace using the sheet metal screws saved earlier. See Figure 2.
18. The conversion is now complete. The furnace may now be installed in the downflow position or in the horizontal position on either side.

INSTALLATION POSITION (150 MBH Models)

This furnace may be installed in an upflow or horizontal position. No conversion is necessary. This furnace is not approved for downflow application.

FLOOR BASE AND DUCTWORK INSTALLATION
Upflow Instructions

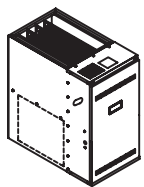

Attach the supply plenum to the furnace outlet duct connection flanges. This is typically through the use of S cleat material when a metal plenum is used. The use of an approved flexible duct connector is recommended on all installations. This connection should be sealed to prevent air leakage. The sheet metal should be cross-hatched to eliminate any popping of the sheet metal when the indoor fan is energized.

When replacing an existing furnace, if the existing plenum is not the same size as the new furnace then the existing plenum must be removed and a new plenum installed that is the proper size for the new furnace. If the plenum is shorter than 12" (30.5 cm) the turbulent air flow may cause the limit controls not to operate as designed, or the limit controls may not operate at all.

The duct system is a very important part of the installation. **If the duct system is improperly sized the furnace will not operate properly.** The ducts attached to the furnace plenum, should be of sufficient size so that the furnace operates at the specified external static pressure and within the air temperature rise specified on the nameplate.

Table 2 is a guide for determining whether the rectangular duct system that the furnace is being connected to be of sufficient size for proper furnace operation.

Use the Example below to help you in calculating the duct area to determine whether the ducts have sufficient area so that the furnace operates at the specified external static pressure and within the air temperature rise specified on the nameplate.

Example: The furnace input is 80,000 BTUH, 1,200 CFM. The recommended duct area is 280 sq.in, there are two 8 x 14 rectangular ducts attached to the plenum and there are two 7 inch round ducts attached to the furnace.

1. Take 8 x 14, which equals 112 sq.in. X 2, which equals 224 square inch then go to round duct size located in Table 2.
2. The square inch area for 7 inch round pipe is 38.4, multiply by 2 for two round ducts which equals 76.8 square inch.
3. Then take the 224 square inch from the rectangular duct and add it to the 76.8 sq.in. of round duct. The total square inch of duct attached to the furnace plenum is 300.8 square inch. This exceeds the recommended 280 square inch of duct.

In this example, the duct system attached to the plenum has a sufficient area so that the furnace operates at the specified external static pressure and within the air temperature rise specified on the nameplate.

Consideration should be given to the heating capacity required and also to the air quantity (CFM) required. These factors can be determined by calculating the heat loss and heat gain of the home or structure. If these calculations are not performed and the furnace is over-sized, the following may result:

1. Short cycling of the furnace.
2. Wide temperature fluctuations from the thermostat setting.
3. Reduced overall operating efficiency of the furnace.

The supply and return duct system must be of adequate size and designed such that the furnace will operate within the designed air temperature rise range and not exceed the maximum designed static pressure. These values are listed Tables 2 and 3.

TABLE 2: Minimum Duct Sizing For Proper Airflow

Input BTU/H (kW)	Airflow CFM (m³)	Return ¹ In² (cm²)	Rectangular ²	Round ²	Supply ³
			in. x in. (cm x cm)	in. (cm) dia.	In² (cm²)
50000 (14.65)	1,200 (33.98)	280 (711)	14 x 20 (35.6 x 50.8)	18 (45.7)	216 (549)
75000 (21.98)	1,200 (33.98)	280 (711)	14 x 20 (35.6 x 50.8)	18 (45.7)	216 (549)
75000 (21.98)	1,600 (45.31)	360 (914)	18 x 20 (45.7 x 50.8)	22 (55.8)	280 (711)
100000 (29.31)	1,600 (45.31)	360 (914)	18 x 20 (45.7 x 50.8)	22 (55.8)	280 (711)
100000 (29.31)	2,000 (56.63)	440 (1,118)	20 x 22 (50.8 x 55.8)	24 (60.9)	390 (991)
125000 (36.63)	2,000 (56.63)	440 (1,118)	20 x 22 (50.8 x 55.8)	24 (60.9)	390 (991)
150000 (43.96)	2,000 (56.63)	440 (1,118)	20 x 22 (50.8 x 55.8)	24 (60.9)	390 (991)

NOTE: This chart does not replace proper duct sizing calculations or take into account static pressure drop for run length and fittings. Watch out for the temperature rise and static pressures.

1. Maximum return air velocity in rigid duct @ 700 feet per minute (19.82 m³ / minute).
2. Example return main trunk duct minimum dimensions.
3. Maximum supply air velocity in rigid duct @ 900 feet per minute (25.49 m³ / minute).

TABLE 3: External Static Pressure Range

Input		Output		Nominal Air Flow		Ext. Static Pressure			
						Minimum		Maximum	
MBH	kW	MBH	kW	CFM	cmm	In.W.C	kPa	In.W.C	kPa
50	14.7	40	11.7	1200	34.0	0.10	0.0249	0.50	0.1245
75	22.0	60	17.6	1200	34.0	0.12	0.0299	0.50	0.1245
75	22.0	60	17.6	1600	45.3	0.12	0.0299	0.50	0.1245
100	29.3	80	23.4	1600	45.3	0.15	0.0374	0.50	0.1245
100	29.3	80	23.4	2000	56.6	0.15	0.0374	0.50	0.1245
125	36.6	100	29.3	2000	56.6	0.20	0.0498	0.50	0.1245
150	44.0	120	35.2	2000	56.6	0.20	0.0498	0.50	0.1245

TABLES 2 and 3 are to be used as a guide only to help the installer determine if the duct sizes are large enough to obtain the proper air flow (CFM) through the furnace. TABLES 2 and 3 ARE NOT to be used to design ductwork for the building where the furnace is being installed. There are several variables associated with proper duct sizing that are not included in the tables. To properly design the ductwork for the building, Refer to the ASHRAE Fundamentals Handbook, Chapter on "DUCT DESIGN" or a company that specializes in Residential and Modular Home duct designs.

IMPORTANT: The minimum plenum height is 12" (30.5). The furnace will not operate properly on a shorter plenum height. The minimum recommended rectangular duct height is 4 inches (10 cm) attached to the plenum.

IMPORTANT: The air temperature rise should be taken only after the furnace has been operating for at least 15 minutes. Temperatures and external static pressures should be taken 6" (15 cm) past the first bend from the furnace in the supply duct and the return duct. If an external filter box or an electronic air cleaner is installed, take the return air readings before the filter box or air cleaner.

WARNING

The supply air temperature **MUST NEVER** exceed the **Maximum Supply Air Temperature**, specified on the nameplate.

Operating the furnace above the maximum supply air temperature will cause the heat exchanger to overheat, causing premature heat exchanger failure. Improper duct sizing, dirty air filters, incorrect manifold pressure, incorrect gas orifice and/or a faulty limit switch can cause the furnace to operate above the maximum supply air temperature. Refer to sections II, III and IX for additional information on correcting the problem.

If a matching cooling coil is used, it may be placed directly on the furnace outlet and sealed to prevent leakage. Follow the coil instructions for installing the supply plenum. On all installations without a coil, a removable access panel is recommended in the outlet duct such that smoke or reflected light would be observable inside the casing to indicate the presence of leaks in the heat exchanger. This access cover shall be attached in such a manner as to prevent leaks.

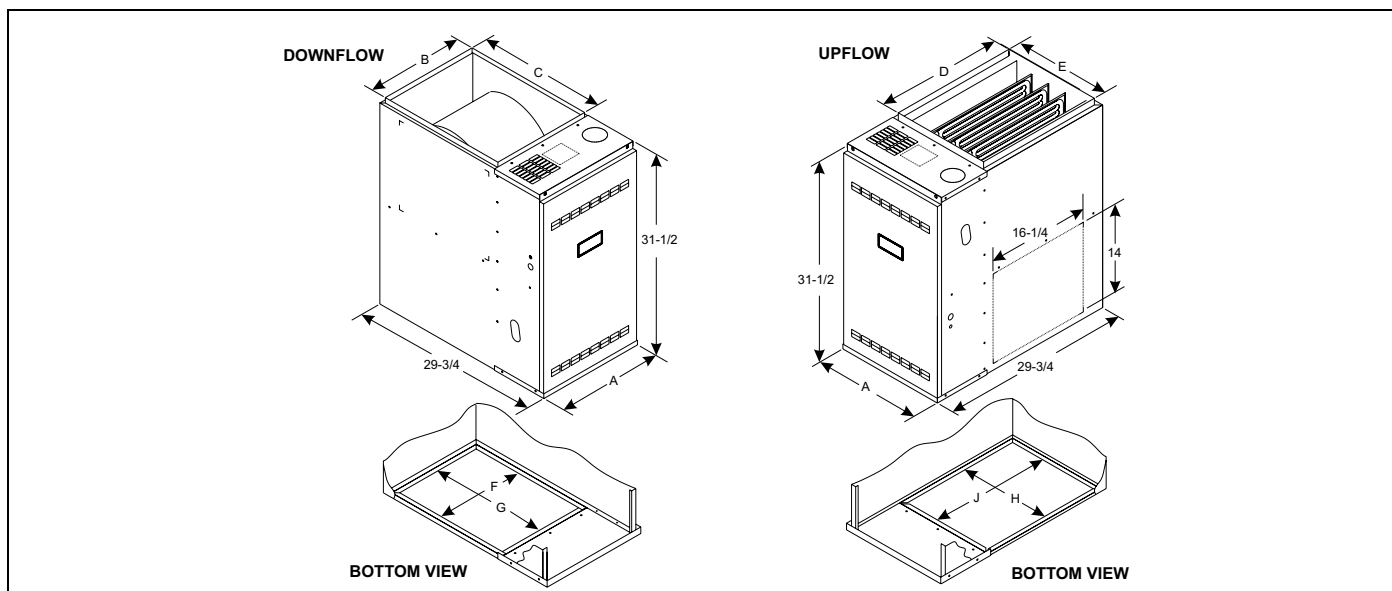

FIGURE 5: Dimensions

TABLE 4: Cabinet and Duct Dimensions

BTUH (kW) Input/Output	Nominal CFM (m ³ /min)	Cabinet Size	Cabinet Dimension									
			A(in.)	A(cm)	B(in.)	B(cm)	C(in.)	C(cm)	D(in.)	D(cm)	E(in.)	E(cm)
50/40 (14.7/11.7) ¹	1200 (33.98)	B	17 1/2	44.4	16 1/2	41.9	20 3/8	51.8	20.0	50.8	16	40.6
75/60 (22.0/17.6) ¹	1200 (33.98)	B	17 1/2	44.5	16 1/2	41.9	20 3/8	51.8	20.0	50.8	16	40.6
75/60 (22.0/17.6) ¹	1600 (45.31)	C	21	53.3	20	50.8	20 3/8	51.8	20.0	50.8	19 1/2	49.5
100/80 (29.3/23.4) ¹	1600 (45.31)	C	21	53.3	20	50.8	20 3/8	51.8	20.0	50.8	19 1/2	49.5
100/80 (29.3/23.4) ¹	2000 (58.63)	D	24.5	62.2	23 1/2	59.7	20 3/8	51.8	20.0	50.8	23	58.4
125/100 (36.6/29.3) ¹	2000 (58.63)	D	24.5	62.2	23 1/2	59.7	20 3/8	51.8	20.0	50.8	23	58.4
150/120 (44.0/35.2) ²	2000 (58.63)	D	24 1/2	62.2	23 1/2	59.7	20 3/8	51.8	20.0	50.8	23	58.4
BTUH (kW) Input/Output	Nominal CFM (m ³ /min)	Cabinet Size	F(in.)	F(cm)	G(in.)	G(cm)	H(in.)	H(cm)	J(in.)	J(cm)	K Vent (in.)	K Vent (cm)
50/40 (14.7/11.7) ¹	1200 (33.98)	B	14 3/4	37.46	18 3/4	47.62	15 1/8	38.4	19.0	48.2	3	7.62
75/60 (22.0/17.6) ¹	1200 (33.98)	B	14 3/4	37.46	18 3/4	47.62	15 1/8	38.4	19.0	48.2	4 ³	10.16 ²
75/60 (22.0/17.6) ¹	1600 (45.31)	C	18 1/4	46.35	18 3/4	47.62	18 5/8	47.3	19.0	48.2	4 ²	10.16 ²
100/80 (29.3/23.4) ¹	1600 (45.31)	C	18 1/4	46.35	18 3/4	47.62	18 5/8	47.3	19.0	48.2	4 ²	10.16 ²
100/80 (29.3/23.4) ¹	2000 (58.63)	D	21 3/4	55.24	18 3/4	47.62	22 1/8	56.2	19.0	48.2	4 ²	10.16 ²
125/100 (36.6/29.3) ¹	2000 (58.63)	D	21 3/4	55.24	18 3/4	47.62	22 1/8	56.2	19.0	48.2	5 ²	12.7 ²
150/120 (44.0/35.2) ³	2000 (58.63)	D	21 3/4	55.24	18 3/4	47.62	22 1/8	56.2	19.0	48.2	5 ²	12.7 ²

- 4-position models may be factory configured as upflow (MU) or downflow (MD).
- All models are supplied with 3" (7.62 cm) vent connections. An installer supplied transition to 4" (10.16 cm) or 5" (12.7 cm) must be used where necessary.
- 3-position 150 MBH model available only in upflow/horizontal (UH) configuration.
- Dimensions "B", "C", "D", and "E" are with duct flanges turned up. "F", "G", "H", & "J" are with flanges flat.

RESIDENTIAL AND NON HUD MODULAR HOME UPFLOW RETURN PLENUM CONNECTION

Return air may enter the furnace through the side(s) or bottom depending on the type of application. Return air may not be connected into the rear panel of the unit. In order to achieve the airflow indicated, it is recommended those applications over 1800 CFM (57 m³/min) use return air from two sides, one side and the bottom or bottom only. For single return application, see data and notes on blower performance data tables in this manual.

NOTE: The only return duct configurations that is approved for models that have two separate fans are:

- Return duct attached to both sides of the furnace.
- Bottom and side return duct.

BOTTOM RETURN AND ATTIC INSTALLATIONS

Bottom return applications normally pull return air through a base platform or return air plenum. Be sure the return platform structure or return air plenum is suitable to support the weight of the furnace.

The return air ducts to the furnace must have a total cross sectional area of not less than two square inches per 1000 BTUH of furnace input rating for heating operation. If air conditioning is to be installed with the furnace, larger return air ducts may be required, depending on the capacity of the air conditioner and the airflow required. The return air opening in the top of the furnace is large enough for the largest capacity air conditioner for which the furnace blower is rated. The return air duct or plenum can be connected to the furnace by performing the following steps:

1. Bend the 3/4" flanges that will be used to attach the return air plenum using the scribe marks in the furnace base. Refer to Figure 5 for flange locations.
2. Be sure to seal the furnace to plenum connections to prevent air leakage. Refer to Figure 5 for unit and plenum dimensions. Attic installations must meet all minimum clearances to combustibles and have floor support with required service accessibility.

Attic installations must meet all minimum clearances to combustibles and have floor support with required service accessibility.

FLOOR BASE AND DUCTWORK INSTALLATION

Downflow Combustible Floor Base

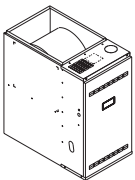

Installations on combustible material or floors must use a combustible floor base shown in Figure 6. The perforations in the wrapper flanges must be bent in towards the heat exchanger to allow for the coil duct flange to recess into the furnace. Follow the instructions supplied with the combustible floor base accessory. This combustible floor base can be replaced with a matching cooling coil, properly sealed to prevent

leaks. Follow the instructions supplied with the cooling coil cabinet for installing the cabinet to the duct connector. Refer to the installation instructions for additional information.

Downflow Duct Connectors

All downflow installations must use a suitable duct connector approved by the furnace manufacturer for use with this furnace. The duct connectors are designed to be connected to the rectangular duct under the floor and sealed. Refer to the instructions supplied with the duct connector for proper installation. Refer to the separate accessory parts list at the end of these instructions for the approved accessory duct connectors.

When replacing an existing furnace, if the existing plenum is not the same size as the new furnace then the existing plenum must be removed and a new plenum installed that is the proper size for the new furnace.

IMPORTANT: If an external mounted filter rack is being used see the instructions provided with that accessory for proper hole cut size.

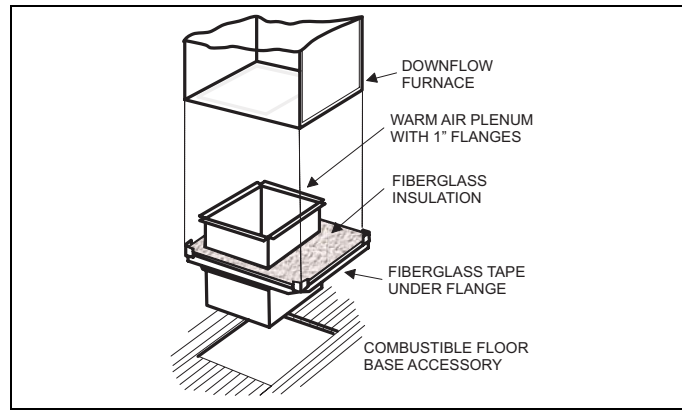

FIGURE 6: Combustible Floor Base Accessory

Downflow Air Conditioning Coil Cabinet

The furnace should be installed with coil cabinet part number specifically intended for downflow application. If a matching cooling coil is used, it may be placed directly on the furnace outlet and sealed to prevent leakage. For details of the coil cabinet dimensions and installation requirements, refer to the installation instructions supplied with the coil cabinet.

The perforations in the wrapper flanges must be bent away from the heat exchanger to create duct flanges so the air conditioning coil can be properly seated on the furnace. Attach the air conditioning coil cabinet to the duct connector, and then position the furnace on top of the coil cabinet. The connection to the furnace, air conditioning coil cabinet, duct connector, and supply air duct must be sealed to prevent air leakage.

IMPORTANT: On all installations without a coil, a removable access panel is recommended in the outlet duct such that smoke or reflected light would be observable inside the casing to indicate the presence of leaks in the heat exchanger. This access cover shall be attached in such a manner as to prevent leaks.

RESIDENTIAL AND NON HUD MODULAR HOME DOWNFLOW RETURN PLENUM CONNECTION

The return duct system must be connected to the furnace inlet and the return duct system must terminate outside the space containing the furnace. When replacing an existing furnace, if the existing plenum is not the same size as the new furnace then the existing plenum must be removed and a new plenum installed that is the proper size for the new furnace.

Attach the return plenum to the furnace inlet duct flanges. This is typically through the use of "S" cleat material when a metal plenum is used. The use of an approved flexible duct connector is recommended on all installations. The connection of the plenum to the furnace and all the ducts connecting to the plenum must be sealed to prevent air leakage. The sheet metal should be crosshatched to eliminate any popping of the sheet metal when the indoor fan is energized.

The duct system is a very important part of the installation. If the duct system is improperly sized the furnace will not operate properly. The ducts attached to the furnace must be of sufficient size so that the furnace operates at the specified external static pressure and within the air temperature rise specified on the nameplate.

IMPORTANT: If an external mounted filter rack is being used see the instructions provided with that accessory for proper hole cut size.

HORIZONTAL MODELS

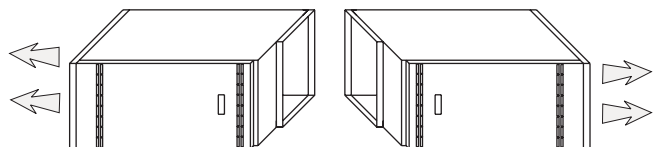

Horizontal Installations With a Cooling Coil Cabinet

The furnace should be installed with coil cabinet part number specifically intended for Horizontal application. If a matching cooling coil is used, it may be placed directly on the furnace outlet and sealed to prevent leakage. Follow the coil instructions for installing the supply plenum. For details of the coil cabinet dimensions and installation requirements, refer to the installation instructions supplied with the coil cabinet.

The perforations in the wrapper flanges must be bent away from the heat exchanger to create duct flanges so the air conditioning coil can be properly seated on the furnace.

Attach the supply plenum to the air conditioning coil cabinet outlet duct flanges through the use of S cleat material when a metal plenum is used. The use of an approved flexible duct connector is recommended on all installations. The connection to the furnace, air conditioning coil cabinet and the supply plenum should be sealed to prevent air leakage. The sheet metal should be crosshatched to eliminate any popping of the sheet metal when the indoor fan is energized.

The minimum plenum height is 12" (30.5 cm). If the plenum is shorter than 12" (30.5 cm) the turbulent air flow may cause the limit controls not to operate as designed, or the limit controls may not operate at all. Also the plastic drain pan in the air conditioning coil can overheat and melt. Refer to the installation instructions supplied with the air conditioning coil for additional information.

Horizontal Installations Without a Cooling Coil Cabinet

When installing this appliance, the furnace must be installed so as to create a closed duct system, the supply duct system must be connected to the furnace outlet and the supply duct system must terminate outside the space containing the furnace. When replacing an existing furnace, if the existing plenum is not the same size as the new furnace then the existing plenum must be removed and a new plenum installed that is the proper size for the new furnace.

Attach the supply plenum to the furnace outlet duct flanges through the use of S cleat material when a metal plenum is used. The use of an approved flexible duct connector is recommended on all installations. This connection should be sealed to prevent air leakage. The sheet metal should be crosshatched to eliminate any popping of the sheet metal when the indoor fan is energized. On all installations without a coil, a removable access panel is recommended in the outlet duct such that smoke or reflected light would be observable inside the casing to indicate the presence of leaks in the heat exchanger. This access cover shall be attached in such a manner as to prevent leaks.

Residential and Non Hud Modular Home Horizontal Return Plenum Connections

The return duct system must be connected to the furnace inlet and the return duct system must terminate outside the space containing the furnace. When replacing an existing furnace, if the existing plenum is not the same size as the new furnace then the existing plenum must be removed and a new plenum installed that is the proper size for the new furnace.

Attach the return plenum to the furnace inlet duct flanges. This is typically through the use of S cleat material when a metal plenum is used. The use of an approved flexible duct connector is recommended on all installations. The connection of the plenum to the furnace and all the ducts connecting to the plenum must be sealed to prevent air leakage. The sheet metal should be crosshatched to eliminate any popping of the sheet metal when the indoor fan is energized.

The duct system is a very important part of the installation. If the duct system is improperly sized the furnace will not operate properly. The ducts attached to the furnace must be of sufficient size so that the furnace operates at the specified external static pressure and within the air temperature rise specified on the nameplate.

Attic installations must meet all minimum clearances to combustibles and have floor support with required service accessibility.

IMPORTANT: if an external mounted filter rack is being used see the instructions provided with that accessory for proper hole cut size.

ATTIC INSTALLATION

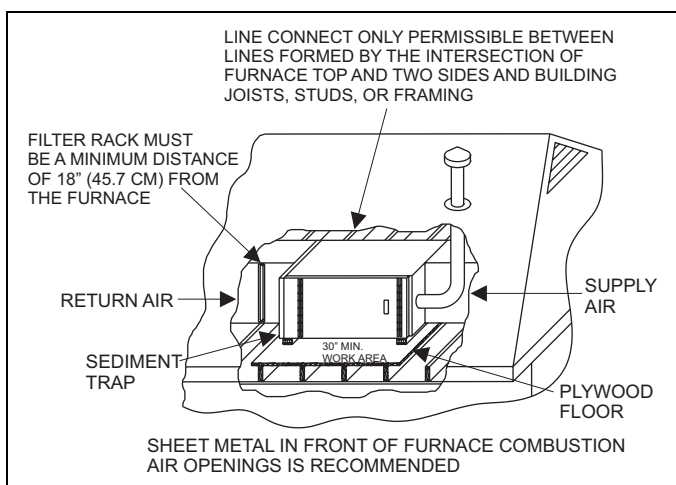

FIGURE 7: Typical Attic Installation

This appliance is design certified for line contact when the furnace is installed in the horizontal left or right position. The line contact is only permissible between lines that are formed by the intersection of the top and two sides of the furnace and the building joists, studs or framing. This line may be in contact with combustible material.

WARNING

When a furnace is installed in an attic or other insulated space, keep all insulating materials at least 12 inches (30.5 Cm) away from furnace and burner combustion air openings.

SUSPENDED FURNACE / CRAWL SPACE INSTALLATION

The furnace can be hung from floor joists or installed on suitable blocks or pad. Blocks or pad installations shall provide adequate height to ensure the unit will not be subject to water damage. Units may also be suspended from rafters or floor joists using rods, pipe angle supports or straps. Angle supports should be placed at the supply air end and near the blower deck. Do not support at return air end of unit. All four suspension points must be level to ensure quiet furnace operation. When suspending the furnace use a secure platform constructed of plywood or other building material secured to the floor joists. Refer to Figure 8 for typical crawl space installation.

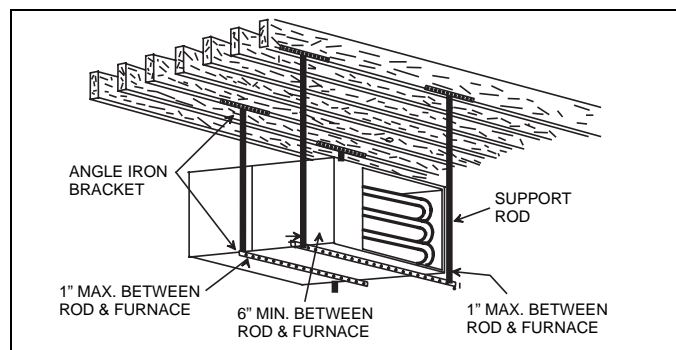

FIGURE 8: Typical Suspended Furnace / Crawl Space Installation

SECTION III: FILTERS

FILTER INSTALLATION

All applications require the use of a filter. A high velocity filter and retainer are provided for field installation on G8C models. Models must have a field-supplied filter and mounting hardware. Replacement filter size is shown in Table 5.

TABLE 5: Filter Sizes - Upflow

UPFLOW						Cabinet Size	Side Return		Bottom/End Return	
Input		Output		Air Flow			in.	cm	in.	cm
MBH	kW	MBH	kW	CFM	cmm					
50	14.7	40	11.7	1200	34.0	B	25 x 16	64 x 41	24 x 15	61 x 38
75	22.0	60	17.6	1200	34.0	B	25 x 16	64 x 41	24 x 15	61 x 38
75	22.0	60	17.6	1600	45.3	C	25 x 16	64 x 41	24 x 18	61 x 46
100	29.3	80	23.4	1600	45.3	C	25 x 16	64 x 41	24 x 18	61 x 46
100	29.3	80	23.4	2000	56.6	D	(2) 25 x 16	(2) 64 x 41	24 x 21	61
125	36.6	100	29.3	2000	56.6	D	(2) 25 x 16	(2) 64 x 41	24 x 21	61
150	44.0	120	35.2	2000	56.6	D	(2) 25 x 16	(2) 64 x 41	24 x 21	61
DOWNFLOW						Cabinet Size	Top Return (Downflow) Cleanable Air Filters		Top Return (Downflow) Disposable Air Filters	
Input		Output		Air Flow			in.	cm	in.	cm
MBH	kW	MBH	kW	CFM	cmm					
50	14.7	40	11.7	1200	34.0	B	14 x 20	(2) 25 x 51	(2) 10 x 20	(2) 25 x 51
75	22.0	60	17.6	1200	34.0	B	14 x 20	(2) 36 x 51	(2) 14 x 20	(2) 36 x 51
75	22.0	60	17.6	1600	45.3	C	16 x 20	(2) 41 x 51	16 x 20	(2) 41 x 51
100	29.3	80	23.4	1600	45.3	C	16 x 20	(2) 41 x 51	16 x 20	(2) 41 x 51
100	29.3	80	23.4	2000	56.6	D	20 x 20	(2) 51 x 51	20 x 20	(2) 51 x 51
125	36.6	100	29.3	2000	56.6	D	20 x 20	(2) 51 x 51	20 x 20	(2) 51 x 51
150	44.0	120	35.2	2000	56.6	D	N/A	N/A	N/A	N/A

SIDE RETURN/BOTTOM EXTERNAL INSTALLATION

Locate and knock out the square corner locators. These indicate the size of the cutout to be made in the furnace side panel. Refer to Figure 9.

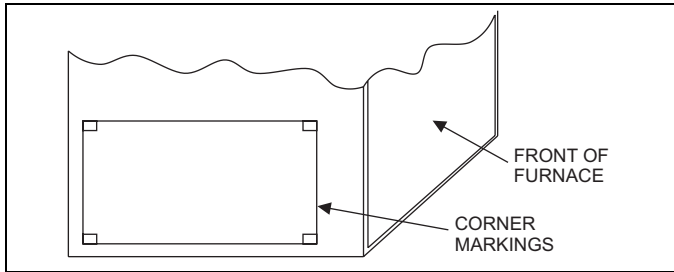

FIGURE 9: Side Return Cutout Markings

Install the side filter rack following the instructions provided with that accessory. If a filter(s) is provided at another location in the return air system, the ductwork may be directly attached to the furnace side panel. An accessory filter rack is available for mounting the filter external to the cabinet.

Some accessories such as electronic air cleaners and pleated media may require a larger side opening. Follow the instructions supplied with that accessory for side opening requirements. Do not cut the opening larger than the dimensions shown in Figure 5.

EXTERNAL INSTALLATION FOR UPFLOW/HORIZONTAL CONFIGURATIONS

1. Select desired filter position for upflow/horizontal (left/right side, side and bottom). Remove the corresponding cabinet cutouts per instructions provided.
2. Install the external filter box to the side of the cabinet and secure to the cabinet as specified in the instructions provided with the air filter kit. If a side return is to be used, cut out the side of the casing 14" high by 16 1/4" wide using the lances in the casing side as a guide. **DO NOT CUT THE OPENING LARGER THAN 14" X 16 1/4"**. It is not permissible to cut out the back of the furnace. For bottom returns you place the external filter box between the return air plenum and the base of the furnace. The casing bottom is embossed to indicate where to bend the flanges. Refer to Figure 5 for the maximum return air opening sizes. Seal this connection to prevent leaks. Do not cut the opening larger than the dimensions shown in Figure 5.
3. Install the return air duct to the air filter box and secure with screws. Seal this connection to prevent leaks.
4. Install the field provided filter. Refer to Table 5 for the recommended filter size for your furnace.

NOTE: Air velocity must not exceed 300 feet per minute through low velocity disposable filters. Air velocity must not exceed 650 feet per minute through high velocity cleanable permanent filters. Use of a filter that is too small will cause static pressure in the duct system to be too high, which will have an adverse effect on heating and cooling operation.

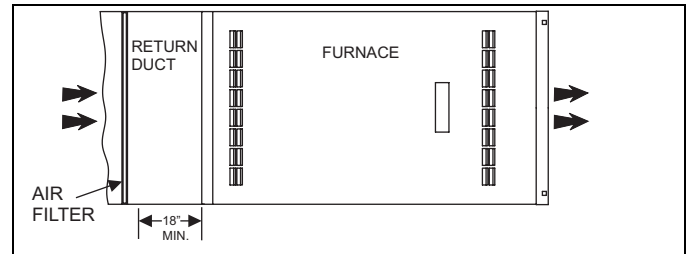

FIGURE 10: Horizontal Mount and Filter

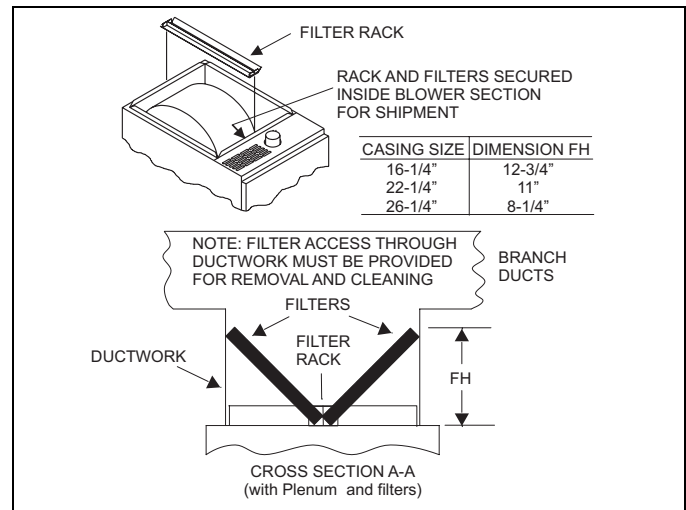

FIGURE 11: Downflow Filter

Downflow Filters

Downflow furnaces typically are installed with the filters located above the furnace, extending into the return air plenum or duct. Any branch duct (rectangular or round duct) attached to the plenum must attach to the vertical plenum above the filter height. Refer to Figure 11 for proper installation.

Filter(s) may be located in the duct system external to the furnace using an external duct filter box attached to the furnace plenum or at the end of the duct in a return filter grille(s). The use of straps and / or supports is required to support the weight of the external filter box. Refer to Figures 10 and 12.

If the accessory electronic air cleaner is installed, be sure the air cleaner is designed to accommodate the furnace CFM (cm/m) and the air cleaner is installed so it does not obstruct the return airflow. Consideration should be given when locating the air cleaner for maintenance and temperatures should the indoor fan motor fail to operate. The use of straps and / or supports is required to support the weight of the electronic air cleaner. It is recommended that the air cleaner not be located within 12 inches (2.5 cm) from the top of the return air opening on the furnace. Refer to the instructions supplied with the electronic air cleaner.

If pleated media air filters or any filter that has a large pressure drop is installed in the return air duct system be sure that the pressure drop caused by the air filter will not prevent the furnace from operating within the rise range specified on the rating plate. If the furnace does not operate within the specified rise range then a larger air filter or an air filter that has a lower pressure drop must be installed. Refer to Table 16 and the furnace accessories for accessory external filter kit options.

IMPORTANT: For easier filter access in a downflow configuration, a removable access panel is recommended in the vertical run of the return air plenum immediately above the furnace.

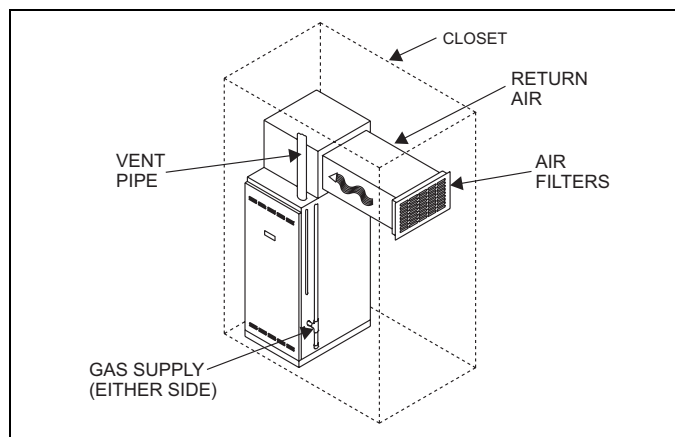

FIGURE 12: Return Filter Grill and Return Duct Installation

Accessory External Filter Installation

1. Install the return filter rack on the top of the furnace return air opening. Secure the filter rack to the front and back flanges with screws. The return air plenum can be placed over the filter rack and the branch ducts (rectangular ducts and / or round ducts) can be attached to the plenum. Route the combustion air and the vent PVC pipes around the access panels for the filters.
2. Install the filter(s) provided or you may install Permanent washable filters. Filter should extend through the entire length of the filter rack to prevent air from bypassing the filter.

IMPORTANT: Air velocity through throwaway type filters must not exceed 300 feet per minute (1.52 m/m). All velocities over this require the use of high velocity filters. Refer to Table 16.

CAUTION

All installations must have a filter installed.

WARNING

For applications requiring more than 1800 CFM, it is required to use the bottom return, both side returns or one side plus the bottom return.

- Single side return is not approved on 5 Ton models.
- 18" minimum height for return air box for bottom return only on Heating only applications with furnace in the upflow configuration.
- 24" minimum height for return air box for bottom return only on A/C applications with furnace in the upflow configuration.

SECTION IV: GAS PIPING

GAS SAFETY

DANGER

This furnace is designed to operate on NATURAL GAS or PROPANE GAS ONLY. Do not burn any other fuel in this furnace. Burning any fuel except NATURAL GAS or PROPANE GAS can cause premature heat exchanger burnout, high levels of carbon monoxide, excessive sooting, a fire hazard, personal injury, property damage and / or death.

DANGER

An overpressure protection device, such as a pressure regulator, must be installed in the gas piping system upstream of the furnace and must act to limit the downstream pressure to the gas valve so it does not exceed 0.5 PSI (14" w.c. (3.48 kPa)). Pressures exceeding 0.5 PSI (14" w.c. (3.48 kPa)) at the gas valve will cause damage to the gas valve, resulting in a fire or explosion or cause damage to the furnace or some of its components that will result in property damage and loss of life.

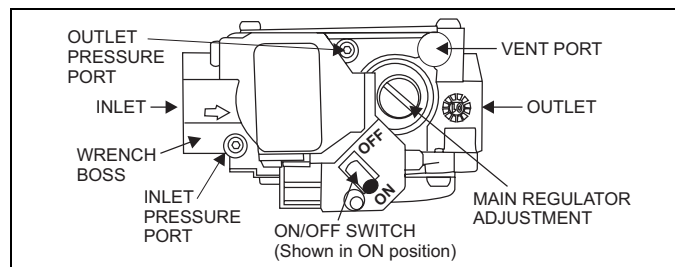

FIGURE 13: Gas Valve

CHECKING THE GAS PRESSURES

1. The pressure ports on the gas valve are marked OUT P and IN P.
2. The manifold pressure must be taken at the port marked OUT P.
3. The inlet gas supply pressure must be taken at the port marked IN P.
4. Using a 3/32" (0.2 cm) Allen wrench, loosen the set screw by turning it 1 turn counter clockwise. **DO NOT REMOVE THE SET SCREW FROM THE PRESSURE PORT.**
5. Push one end the 3/8" (0.9 cm) ID flexible tubing over the pressure port so that the body of the port is inside the tubing.
6. Use a reducer connector to connect the 3/8" (0.9 cm) ID flexible tube to a 1/4" (0.9 cm) ID flexible tube that is connected to a "U" tube manometer or digital pressure measuring equipment.

TABLE 6: Inlet Gas Pressure Range

INLET GAS PRESSURE RANGE		
	Natural Gas	Propane (LP)
Minimum	4.5" W.C. (1.12 kPa)	8.0" W.C. (1.99 kPa)
Maximum	10.5" W.C. (2.61 kPa)	13.0" (3.24 kPa) W.C.

IMPORTANT: The inlet gas pressure operating range table specifies what the minimum and maximum gas line pressures must be for the furnace to operate safely. The gas line pressure **MUST BE** a minimum of:

- 7" W.C. (1.74 kPa) for Natural Gas
- 11" W.C. (2.74 kPa) for Propane (LP) Gas

in order to obtain the BTU input specified on the rating plate and/or the nominal manifold pressure specified in these instructions and on the rating plate.

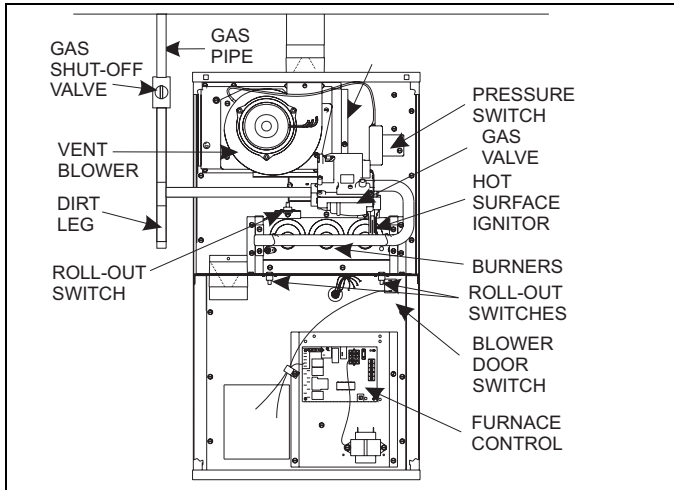

FIGURE 14: Upflow Configuration (50-125 MBH Model Only)

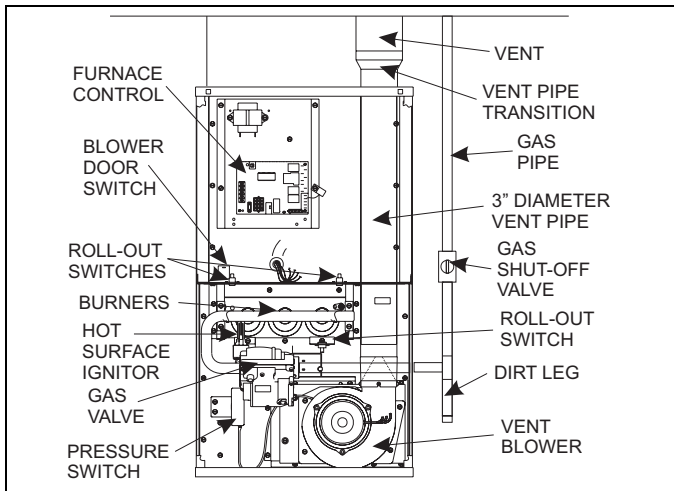

FIGURE 15: Downflow Configuration (50-125 MBH Model Only)

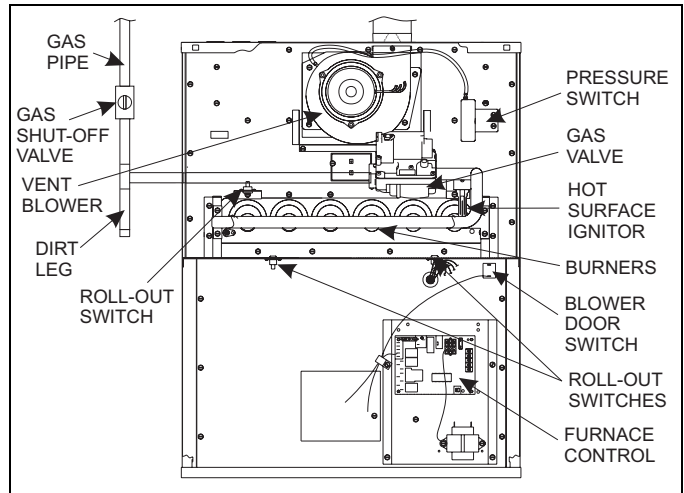

FIGURE 16: Upflow/Horizontal Configuration (150 MBH Model Only)

GAS PIPING INSTALLATION

Properly sized wrought iron, approved flexible or steel pipe must be used when making gas connections to the unit. If local codes allow the use of a flexible gas appliance connection, always use a new listed connector. Do not use a connector that has previously serviced another gas appliance.

Some utility companies or local codes require pipe sizes larger than the minimum sizes listed in these instructions and in the codes. The furnace rating plate and the instructions in this section specify the type of gas approved for this furnace - only use those approved gases. The installation of a drip leg and ground union is required. Refer to Figure 17.

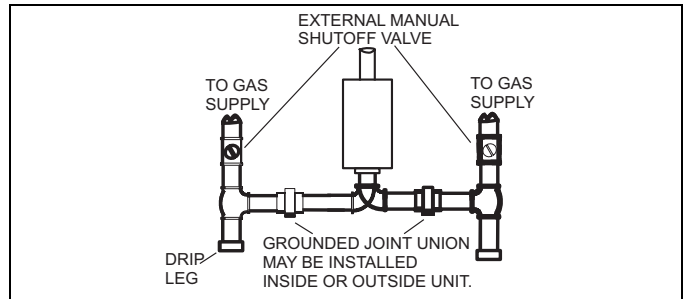

FIGURE 17: Gas Piping

IMPORTANT: An accessible manual shutoff valve must be installed upstream of the furnace gas controls and within 6 feet (1.8 m) of the furnace. Refer to Figures 14, 15, and 16.

The furnace must be isolated from the gas supply piping system by closing its individual external manual shutoff valve during any pressure testing of the gas supply piping system at pressures equal to or less than 1/2 psig (3.5 kPa).

⚠ CAUTION

The gas valve body is a very thin casting that cannot take any external pressure. Never apply a pipe wrench to the body of the gas valve when installing piping. A wrench must be placed on the octagon hub located on the gas inlet side of the valve. Placing a wrench to the body of the gas valve will damage the valve causing improper operation and/or the valve to leak.

Gas piping may be connected from either side of the furnace using any of the gas pipe entry knockouts on both sides of the furnace. Refer to Figure 5 dimensions.

GAS ORIFICE CONVERSION FOR PROPANE (LP)

This furnace is constructed at the factory for natural gas-fired operation, but may be converted to operate on propane (LP) gas by using a factory-supplied LP conversion kit. Follow the instructions supplied with the LP kit. Refer to Table 7 or the instructions in the propane (LP) conversion kit for the proper gas orifice size.

HIGH ALTITUDE GAS ORIFICE CONVERSION

This furnace is constructed at the factory for natural gas-fired operation at 0 – 2,000 ft. (0 m – 610 m) above sea level.

The gas orifices on this furnace must be changed in order to maintain proper and safe operation, when the furnace is installed in a location where the altitude is greater than 2,000 ft. (610 m) above sea level on natural gas or the altitude is greater than 4,000 ft. (1219 m) above sea level on propane (LP) gas. Refer to Table 7 for the proper gas orifice size.

The unit may also be converted for altitudes up to 10,000 ft. (3048 m) on natural and propane (LP) gas with additional derate as shown in Table 7 or refer to ANSI Z223.1 NFPA 54 National Fuel Gas Code or in Canada CAN/CGA-B149.1-00 Natural Gas and Propane Installation Code.

DANGER

PROPANE AND HIGH ALTITUDE CONVERSION KITS

It is very important to choose the correct kit and/or gas orifices for the altitude and the type of gas for which the furnace is being installed.

Only use natural gas in furnaces designed for natural gas. Only use propane (LP) gas for furnaces that have been properly converted to use propane (LP) gas. Do not use this furnace with butane gas.

Incorrect gas orifices or a furnace that has been improperly converted will create an extremely dangerous condition resulting in premature heat exchanger failure, excessive sooting, high levels of carbon monoxide, personal injury, property damage, a fire hazard and/or death.

High altitude and propane (LP) conversions are required in order for the appliance to satisfactorily meet the application.

An authorized distributor or dealer must make all gas conversions.

In Canada, a certified conversion station or other qualified agency, using factory specified and/or approved parts, must perform the conversion.

The installer must take every precaution to insure that the furnace has been converted to the proper gas orifice size when the furnace is installed. Do not attempt to drill out any orifices to obtain the proper orifice size. Drilling out a gas orifice will cause misalignment of the burner flames, causing premature heat exchanger burnout, high levels of carbon monoxide, excessive sooting, a fire hazard, personal injury, property damage and/or death.

TABLE 7: High Altitude Conversion

Type Of Gas	Orifice at Sea Level	2,000 ft. (610 m)	3,000 ft. (914 m)	4,000 ft. (1219 m)	5,000 ft. (1524 m)	6,000 ft. (1829 m)	7,000 ft. (2134 m)	8,000 ft. (2438 m)	9,000 ft. (2743 m)	10,000 ft. (3048 m)
Natural	#42	#42	#43	#43	#43	#44	#44	#45	#46	#47
Propane	#54	#54	#55	#55	#55	#55	#55	#56	#56	#56

SECTION V: ELECTRICAL POWER

Electrical Power Connections

Field wiring to the unit must be grounded. Electric wires that are field installed shall conform to the temperature limitation for 63°F (35°C) rise wire when installed in accordance with instructions. Refer to Table 8 in these instructions for specific furnace electrical data.

TABLE 8: Ratings & Physical / Electrical Data - Upflow Models

Input		Output		Nominal		Cabinet Width		AFUE	Air Temp. Rise		Operation WGT.	Operation WGT.
MBH	kW	MBH	kW	CFM	cmm	In.	cm		°F	°C		
50	14.7	40	11.7	1200	34.0	17-1/2	44.45	80.0	30-60	16.7-33.3		
75	22.0	60	17.6	1200	34.0	17-1/2	44.45	80.0	35-65	19.4-36.1		
75	22.0	60	17.6	1600	45.3	21	53.34	80.0	30-60	16.7-33.3		
100	29.3	80	23.4	1600	45.3	21	53.34	80.0	40-70	22.2-38.9		
100	29.3	80	23.4	2000	56.6	24 1/2	62.23	80.0	35-65	19.4-36.1		
125	36.6	100	29.3	2000	56.6	24 1/2	62.23	80.0	40-70	22.2-38.9		
150	44.0	120	35.2	2000	56.6	24 1/2	62.23	80.0	40-70	22.2-38.9		
Input		Max. Outlet Air Temp		Blower		Blower Size		Total Unit	Max Over-current Size (awg) @ 75 ft.	Min. Wire	Operation WGT.	Operation WGT.
MBH	kW	°F	°C	Hp	Amps	In.	cm	amps	protect	one way	LBS	Kg
50	14.7	160	71.1	1/3	6.2	10 x 8	25.4 x 20.3	6.7	15	14	112	50.8
75	22.0	165	73.9	1/3	6.2	10 x 8	25.4 x 20.3	6.7	15	14	118	53.5
75	22.0	160	71.1	1/2	6.2	10 x 10	25.4 x 25.4	8.5	15	14	129	58.5
100	29.3	170	76.7	1/2	7.0	10 x 10	25.4 x 25.4	8.5	15	14	135	61.2
100	29.3	165	73.9	3/4	12.2	(2)10 x 6	(2) 25.4 x 15.2	10.3	15	14	149	67.6
125	36.6	170	76.7	3/4	12.2	(2)10 x 6	(2) 25.4 x 15.2	10.3	15	14	155	70.3
150	44.0	170	76.7	3/4	12.2	(2)10 x 6	(2) 25.4 x 15.2	10.3	15	14	165	74.8

Annual Fuel Utilization Efficiency (AFUE) numbers are determined in accordance with DOE Test procedures.

Wire size and over current protection must comply with the National Electrical Code (NFPA-70-latest edition) and all local codes.

The furnace shall be installed so that the electrical components are protected from water.

CAUTION

Use copper conductors only.

SUPPLY VOLTAGE CONNECTIONS

1. Provide a power supply separate from all other circuits. Install overcurrent protection and disconnect switch per local/national electrical codes. The switch should be close to the unit for convenience in servicing. With the disconnect or fused switch in the OFF position, check all wiring against the unit wiring label. Refer to the wiring diagram in this instruction.
2. Remove the screws retaining the wiring box cover. Route the power wiring through the opening in the unit into the junction box with a conduit connector or other proper connection. In the junction box there will be three wires, a Black Wire, a White Wire and a Green Wire. Connect the power supply as shown on the unit-wiring label on the inside of the blower compartment door or the wiring schematic in this section. The black furnace lead must be connected to the L1 (hot) wire from the power supply. The white furnace lead must be connected to neutral. Connect the green furnace lead (equipment ground) to the power supply ground. An alternate wiring method is to use a field provided 2" (51 mm) x 4" (102 mm) box and cover on the outside of the furnace. Route the furnace leads into the box using a protective bushing where the wires pass through the furnace panel. After making the wiring connections replace the wiring box cover and screws. Refer to Figure 18.
3. The furnace's control system requires correct polarity of the power supply and a proper ground connection. Refer to Figure 19.

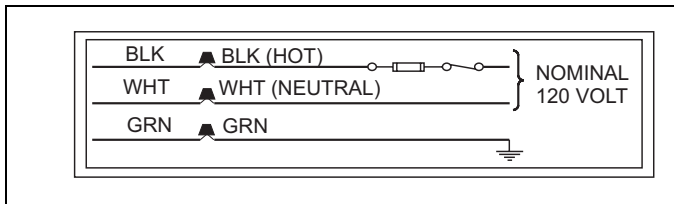

FIGURE 18: Electrical Wiring - Upflow Position

IMPORTANT: The power connection leads and wiring box may be relocated to the left side of the furnace. Remove the screws and cut wire tie holding excess wiring. Reposition on the left side of the furnace and fasten using holes provided.

LOW VOLTAGE CONTROL WIRING CONNECTIONS

Install the field-supplied thermostat by following the instructions that come with the thermostat. With the thermostat set in the OFF position and the main electrical source disconnected, connect the thermostat wiring from the wiring connections on the thermostat to the terminal board on the ignition module, as shown in Figure 20. Electronic thermostats may require the common wire to be connected as shown with the dashed line in Figure 20. Apply strain relief to thermostat wires passing through cabinet. If air conditioning equipment is installed, use thermostat wiring to connect the Y and C terminals on the furnace control board to the yellow and brown wires on the condensing unit (unit outside). Refer to Figure 20.

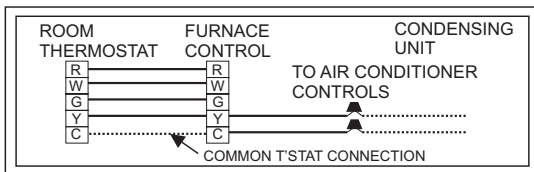

FIGURE 19: Line Wiring Connections

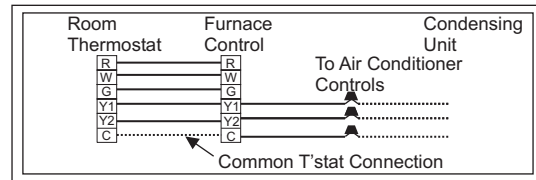

FIGURE 20: Two-Stage Heating and Cooling Thermostat Connections

IMPORTANT: Some electronic thermostats do not have adjustable heat anticipators. They may have other type cycle rate adjustments. Follow the thermostat manufacturer's instructions.

IMPORTANT: Set the heat anticipator in the room thermostat to 0.40 amps. Setting it lower will cause short cycles. Setting it higher will cause the room temperature to exceed the set points.

The 24-volt, 40 VA transformer is sized for the furnace components only, and should not be connected to power auxiliary devices such as humidifiers, air cleaners, etc. The transformer may provide power for an air conditioning unit contactor.

SECTION VI: ACCESSORY CONNECTIONS

The furnace control will allow power-switching control of various accessories. Refer to Figure 21 for connection details.

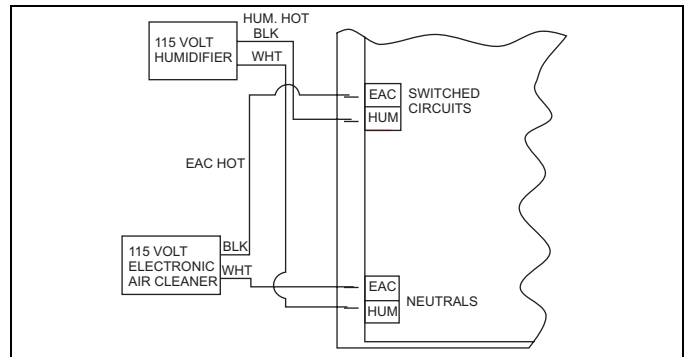

FIGURE 21: Accessory Connections

ELECTRONIC AIR CLEANER CONNECTION

Two 1/4" (0.6 cm) spade terminals (EAC and EAC N) for electronic air cleaner connections are located on the control board. The terminals provide 115 VAC (1.0 amp maximum) during circulating blower operation.

HUMIDIFIER CONNECTION

Two 1/4" (0.6 cm) spade terminals (HUM and HUM N) for humidifier connections are located on the control board. The terminals provide 115 VAC (1.0 amp maximum) during heating system operation.

SECTION VII: TWINNING AND STAGING

NOTE: You can twin two furnaces that have the same integrated control module. Check the part number on the integrated control module. You **cannot twin** two furnaces that have different integrated control module part numbers. If the part numbers of the two integrated control modules are different they may not communicate with each other so they will not work in a twinning application.

In applications where more heating capacity or more airflow capacity is needed than what one furnace can deliver, twinning can be used to make two furnaces operate in tandem. When two furnaces are installed using the same duct system, it is very important that the two furnace circulating air blowers operate in unison. If one blower starts before the second blower, the duct system will become pressurized and the blower on the second furnace will turn backwards causing the second furnace to overheat, resulting in damage to the furnace. Twinning is used to make two furnaces operate in tandem, using one duct system, one room thermostat and causing both furnaces to turn on and off simultaneously.

▲ WARNING

Before installing the relay and wiring, disconnect electrical power to both furnaces. Failure to cut power could result in electrical shock or equipment damage.

TWINNING DUCT SYSTEM

Twinned furnaces must only be applied on a common duct system. A single air supply plenum must be used for both furnaces and coil(s). Separate plenums and supply ducts systems cannot be utilized. A single return air plenum, common to both furnaces must be used. It is suggested that a return platform be utilized, with bottom air entrance into each furnace. If a side entrance returns system is used, the common return duct must be divided equally so as to supply each furnace with an equal amount of return air.

Both furnaces must be identical models in both heating capacity and CFM capacity. Both furnaces must be operated on the same motor speed tap. See typical application, Figure 22.

If furnace staging is desired with two single stage furnaces on a common duct, where the gas burner on the first furnace operates on W1 and the gas burner on the second furnace operates on W2, then the use of an air-mixing device in the plenum to mix the air from both furnaces is strongly recommended. The mixing device must be installed before any ducts that supply air to occupied spaces. Twinning causes both indoor fans to operate simultaneously. If a mixing device is not used, any ducts that are connected down stream from the furnace that operates on W2, will be supplying cold air in the Heating mode to the occupied spaces unless W2 is energized.

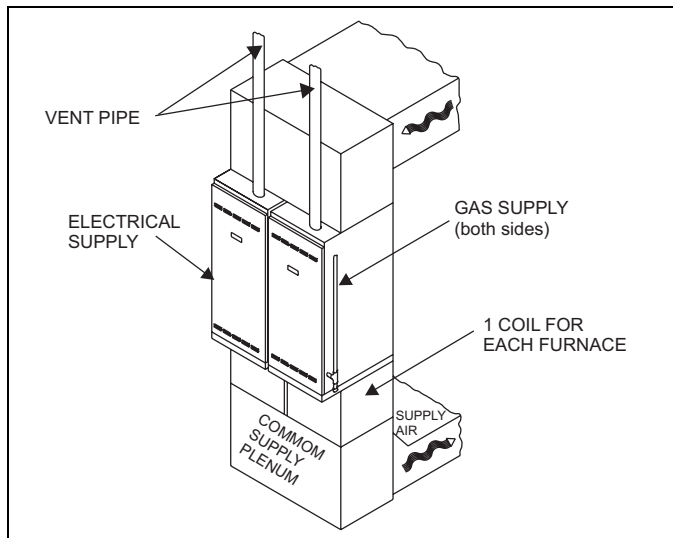

FIGURE 22: Typical Twinned Furnace Application

IMPORTANT: When two furnaces are twinned, typical system total air flow will be approximately 85% of additive individual furnaces, i.e., two 2000 CFM units will yield a total 3400 CFM.

▲ CAUTION

If a return duct is connected to only one furnace (with a connection between the two furnaces) an imbalance in the airflow will occur and the furnace furthest from the return plenum will overheat.

GAS PIPING

Furnace gas supplies must be provided as specified with these instructions. Since the furnaces are side by side, with no space between, gas supplies must enter on the right and left respectively. All gas piping must be in accordance with the national fuel gas code, ANSI Z223.1, latest edition, and/or all local code or utility requirements.

TWINNING

Single-Wire Twinning

The control in the furnace has the single-wire twinning feature. With this feature, a single wire is connected between the TWIN terminal on one furnace board to the TWIN terminal on the second furnace board. The board then communicates the blower status from one furnace to the other along this wire. This communication makes the second furnace blower come on at the same time, and on the same speed, as the first furnace blower.

Single-Wire Twinning Instructions

Connect the control wiring as shown in the Figure 23.

1. Connect the low voltage wiring from the wall thermostat to the terminal strip on the control board of Furnace #1.
2. Connect a wire from the TWIN terminal of Furnace #1 to the TWIN terminal of Furnace #2.
3. Install a separate 24V relay as shown in the diagram below. Use of this relay is required, as it ensures that the transformers of the two furnaces are isolated, thus preventing the possibility of any safety devices being bypassed.

▲ CAUTION

The relay must not be installed in any location where it could be exposed to water. If the relay has been exposed to water in any way, it must not be used.

Single-Wire Twinning Operation

Heating - On a call for heat (W signal) from the wall thermostat, both furnaces will start the ignition sequence and the burners on both furnaces will light. About thirty seconds after the burners light, the blowers on both furnaces will come on in heating speed. When the thermostat is satisfied, the burners will all shut off and, after the selected blower off delay time, both blowers will shut off at the same time. The twinned controls ensure that both blowers come on and shut off at the same time.

Cooling - On a call for cooling (Y signal) from the wall thermostat, both furnace blowers will come on at the same time in cooling speed. When the thermostat is satisfied, both blowers will stay on for 60 seconds, then will shut off at the same time.

Continuous Fan - On a thermostat call for continuous fan (G signal), both furnace blowers will come on at the same time in cooling speed and will stay on until the G signal is removed.

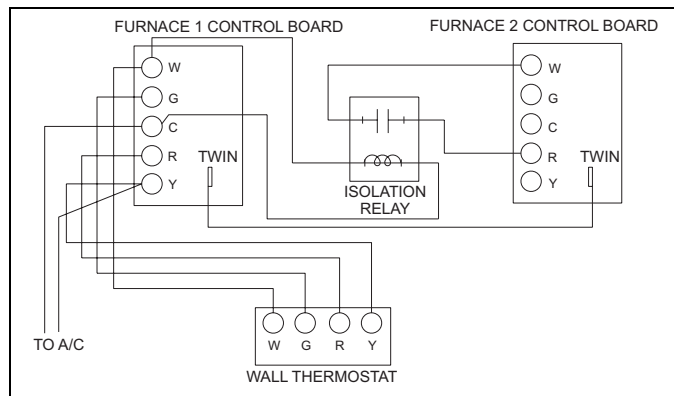

FIGURE 23: Single Stage Twinning Wiring Diagram

STAGING

In applications where more heating capacity or more airflow capacity is needed than what one furnace can deliver, twinning can be used to make two furnaces operate in tandem, using one duct system and one room thermostat. This control can also be used along with a two-stage wall thermostat to stage two twinned furnaces, making them operate like a single two-stage furnace. This allows only one furnace to supply heat during times when the heat output from one furnace is sufficient to satisfy the demand. When one duct system is used for two furnaces, it is necessary that the two blowers operate in unison. The twinning function of this board ensures that both blowers turn on and off simultaneously, and operate on the same blower speed. Even when only one furnace is supplying heat, both furnace blowers must run.

Single-Wire Staging

The single-wire twinning feature of this board can also be used for staging of two furnaces. With this feature, a single wire is connected between the TWIN terminal on one furnace board to the TWIN terminal on the second furnace board. The board then communicates the blower status from one furnace to the other along this wire. This communication makes the second furnace blower come on at the same time, and on the same speed, as the first furnace blower.

Single-Wire Staging Instructions

Connect the control wiring as shown in the Figure 24.

1. Connect the low voltage wiring from the wall thermostat to the terminal strip on the control board of Furnace #1. For staging applications, the wire from thermostat W1 is connected to the W connection on the board on Furnace #1. The wire from thermostat W2 is connected to Furnace #2 through a separate relay, as described below.
2. Connect a wire from the TWIN terminal of Furnace #1 to the TWIN terminal of Furnace #2.
3. Install a separate 24V relay as shown in the diagram below. Use of this relay is required, as it ensures that the transformers of the two furnaces are isolated, thus preventing the possibility of any safety devices being bypassed.

Single-Wire Staging Operation

Heating - On a call for first-stage heat (W1 signal) from the wall thermostat, Furnace #1 will start the ignition sequence and the burners will light. About thirty seconds after the burners light, the blowers on both furnaces will come on in heating speed. When the thermostat is satisfied, the burners will shut off and, after the selected blower off delay time, both blowers will shut off at the same time. On a call for second stage of heat, the burners of Furnace #2 will also light and both blowers will run. The twinning control ensures that both blowers come on and shut off at the same time.

Cooling - On a call for cooling (Y signal) from the wall thermostat, both furnace blowers will come on at the same time. When the thermostat is satisfied, both blowers will stay on for 60 seconds, then will shut off at the same time.

Continuous Fan - On a thermostat call for continuous fan (G signal), both furnace blowers will come on at the same time in cooling speed and will stay on until the G signal is removed.

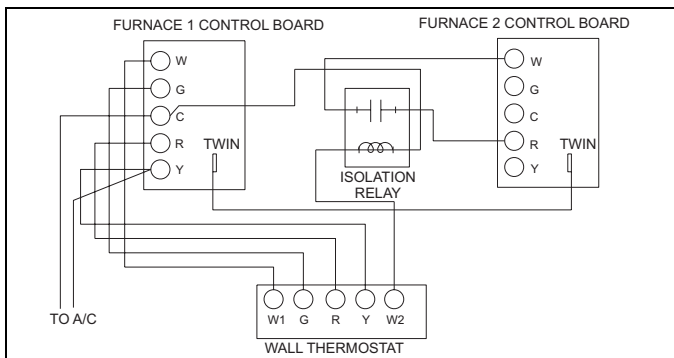

FIGURE 24: Two-Stage Twinning Wiring Diagram

SECTION VIII: VENT/COMBUSTION AIR SYSTEM

VENT SAFETY

This Category I, furnace is designed for residential application. It may be installed without modification in a basement, garage, equipment room, alcove, attic or any other indoor location where all required clearance to combustibles and other restrictions are met.

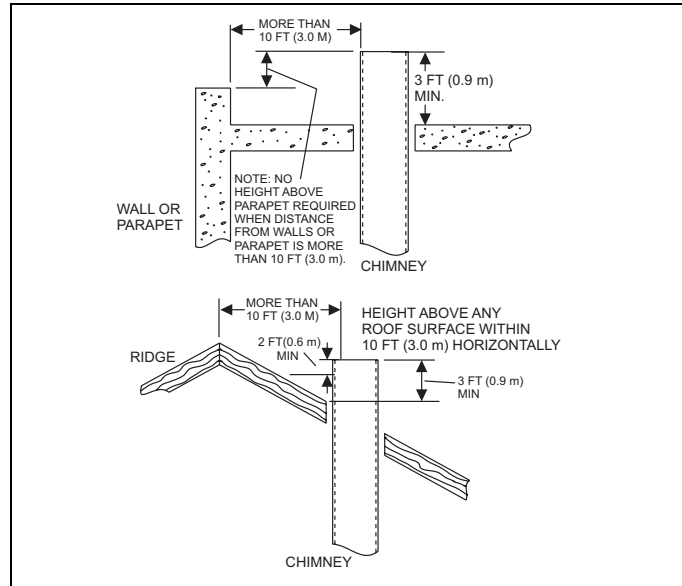

FIGURE 25: Vent Termination

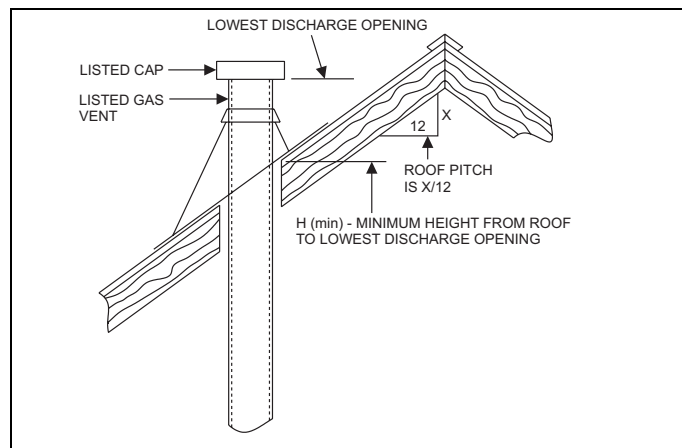

FIGURE 26: Vent Termination

TABLE 9: Roof Pitch

ROOF PITCH	H(min) ft	m
Flat to 6/12	1.0	0.30
6/12 to 7/12	1.25	0.38
Over 7/12 to 8/12	1.5	0.46
Over 8/12 to 9/12	2.0	0.61
Over 9/12 to 10/12	2.5	0.76
Over 10/12 to 11/12	3.25	0.99
Over 11/12 to 12/12	4.0	1.22
Over 12/12 to 14/12	5.0	1.52
Over 14/12 to 16/12	6.0	1.83
Over 16/12 to 18/12	7.0	2.13
Over 18/12 to 20/12	7.5	2.27
Over 20/12 to 21/12	8.0	2.44

CATEGORY 1 - 450 F. MAX. VENT TEMP.

The venting system must be installed in accordance with Section 5.3, Air for Combustion and Ventilation, of the National Fuel Gas Code Z223.1/NFPA 54 (latest edition), or Sections 7.2, 7.3 or 7.4 of CSA B149.1, National Gas and Propane Codes (latest edition) or applicable provisions of the local building code and these instructions.

The furnace shall be connected to any type of B, BW or L vent connector, and shall be connected to a factory-built or masonry chimney. **The furnace shall not be connected to a chimney flue serving a separate appliance designed to burn solid fuel.**

The furnace rating plate lists the maximum vent gas temperature. This temperature must be used to select the appropriate venting materials and clearances.

It is recommended that the appliance is installed in a location where the space temperature is 32 °F (0°C) or higher. If the appliance is installed in a location where the ambient temperature is below 32 °F (0°C), the flue by-products could condense causing damage to the appliance heat exchanger.

IMPORTANT: The "VENT SYSTEM" must be installed as specified in these instructions for Residential and Non HUD Modular Homes.

This appliance may be common vented with another gas appliance for residential installations as allowed by the codes and standards listed in these instructions.

Non-HUD approved Modular Homes must be vented with a listed double wall or B-vent system and may not be common vented with other appliances.

VENTING

Category I venting consists of vertically venting one or more appliances in B-vent or masonry chimney (as allowed), using single wall metal pipe or B-vent connectors. Type B-vent system extends in a general vertical direction and does not contain offsets exceeding 45 degrees. A vent system having not more than one 60 degree offset is permitted.

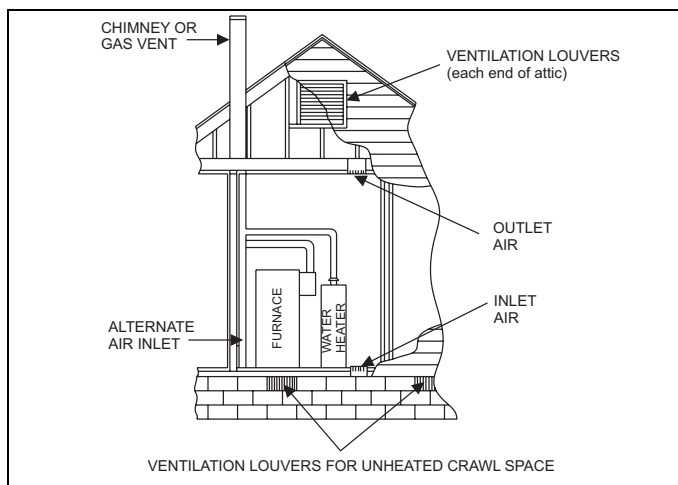

FIGURE 27: Alternate Air Intake, Air Outlet and Chimney Connections

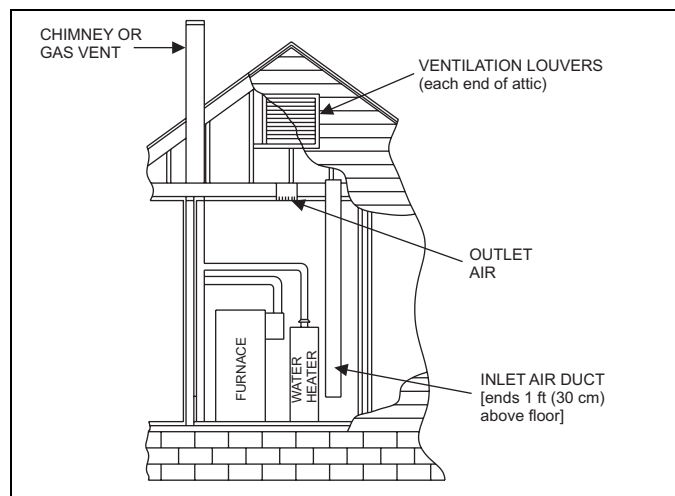

FIGURE 28: Air Inlet, Outlet and Chimney Connections

VENTING INTO AN EXISTING CHIMNEY

For Category I installations, the furnace shall be connected to a factory built chimney or vent complying with a recognized standard, or a masonry or concrete chimney lined with a material acceptable to the authority having jurisdiction. Venting into an unlined masonry chimney or concrete chimney is prohibited.

Whenever possible, B-1 metal pipe should be used for venting. Where use of an existing chimney is unavoidable, the following rules must be followed:

1. The masonry chimney must be built and installed in accordance with nationally recognized building codes or standards and must be lined with approved fire clay tile flue liners or other approved liner material that will resist corrosion, softening, or cracking from flue gases. **THIS FURNACE IS NOT TO BE VENTED INTO AN UNLINED MASONRY CHIMNEY.**
2. This furnace must be vented into a fire clay tile lined masonry chimney only if a source of dilution air is provided, such as by common venting with a draft hood equipped water heater. If no source of dilution air is available, Type B vent must be used, or masonry chimney vent kit 1CK0603 or 1CK0604 must be used. Refer to the instructions with the kit to properly apply these masonry chimney kits.
3. The chimney must extend at least three feet above the highest point where it passes through a roof of a building and at least two feet higher than any portion of the building with a horizontal distance of ten feet.
4. The chimney must extend at least five feet above the highest equipment draft hood or flue collar.

HORIZONTAL SIDEWALL VENTING

For applications where vertical venting is not possible, the only approved method of horizontal venting is the use of an auxiliary power vent. Approved power venters are Fields Controls Model SWG-4Y or Tjernlund Model GPAK-JT. Follow all application and installation details provided by the manufacturer of the power vent. Refer to Figures 29 and 30 for typical installation views.

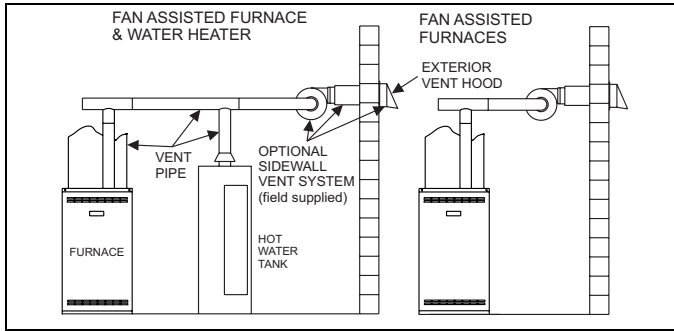

FIGURE 29: Typical Sidewall Vent Application

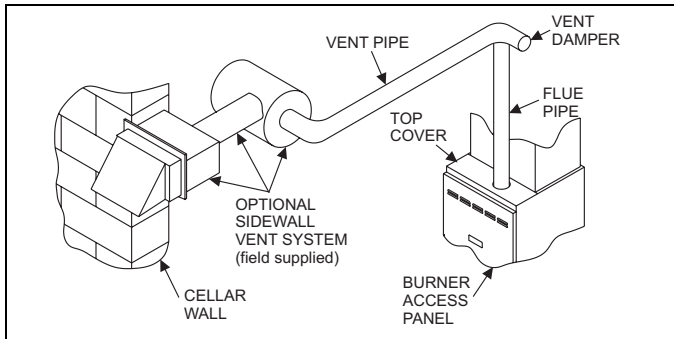

FIGURE 30: Typical Sidewall Vent and Termination Configuration

VENT PIPING ASSEMBLY

The final assembly procedure for the vent piping is as follows:

1. Cut piping to the proper length beginning at the furnace.
2. Deburr the piping inside and outside.
3. Dry-fit the vent piping assembly from the furnace to the termination checking for proper fit support and slope. Piping should be supported with pipe hangers to prevent sagging. The maximum spacing between hangers is 4 feet (1.22 m).
4. Assemble the vent piping from the furnace to the termination securing the pipe connections with screws.

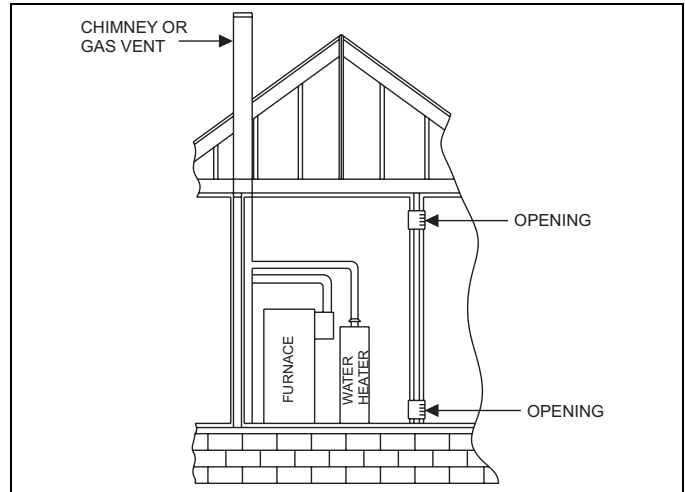

FIGURE 31: Typical Chimney Connections

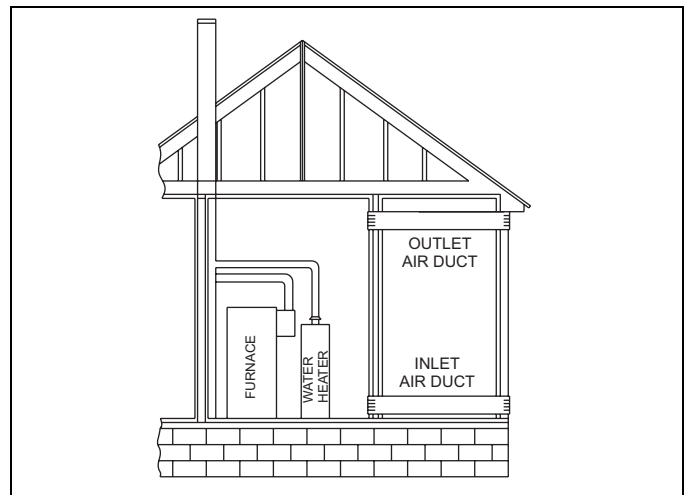

FIGURE 32: Horizontal Air Inlet, Outlet and Chimney Connections

VENT CLEARANCES

IMPORTANT: The vent must be installed with the following minimum clearances as shown in Figure 33, and must comply with local codes and requirements.

TABLE 10: Horizontal Sidewall Venting Clearances

						Horizontal Vent Length Ft. (m) with 4 Elbows					
Heating Input	Heating Input	Heating Output	Heating Output	Furnace Airflow	Furnace Airflow	Pipe Size		Min. Vent Length		Max. Vent Length	
						Inches	cm	Feet	meters	Feet	meters
40,000	11.72	32,000	9.38	1200	33.98	4	10.16	4.5	1.37	34.5	10.82
60,000	17.58	48,000	14.07	1200	33.98	4	10.16	4.5	1.37	34.5	10.82
80,000	23.44	64,000	18.76	1200	33.98	4	10.16	4.5	1.37	34.5	10.82
80,000	23.44	64,000	18.76	1600	45.31	4	10.16	4.5	1.37	34.5	10.82
100,000	29.31	80,000	23.45	1200	33.98	4	10.16	4.5	1.37	34.5	10.82
100,000	29.31	80,000	23.45	2000	56.63	4	10.16	4.5	1.37	34.5	10.82
115,000	33.70	92,000	26.96	1600	45.31	4	10.16	4.5	1.37	34.5	10.82
115,000	33.70	92,000	26.96	2000	56.63	4	10.16	4.5	1.37	34.5	10.82
130,000	38.10	104,000	30.48	2000	56.63	4	10.16	4.5	1.37	34.5	10.82

VENT CLEARANCES

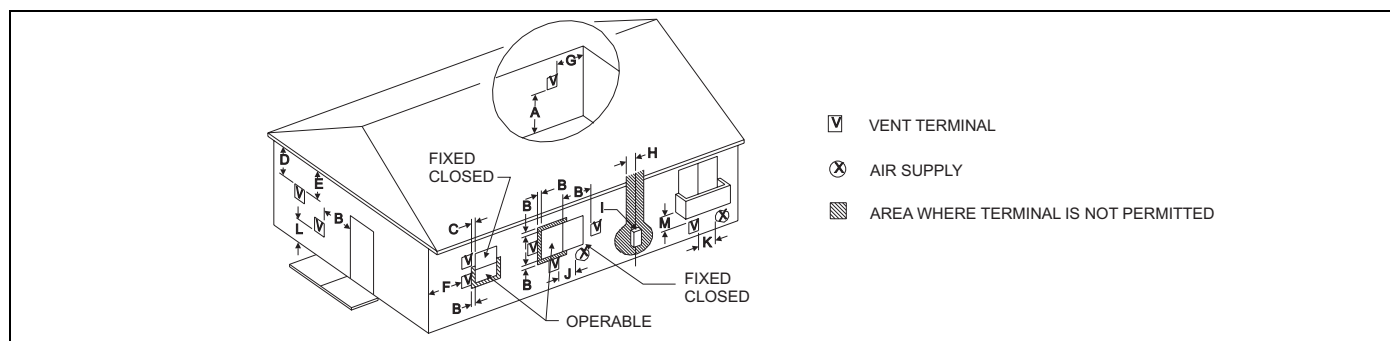

FIGURE 33: Home Layout

	Canadian Installations ¹	US Installation ²
A. Clearance above grade, veranda, porch, deck, or balcony	12 inches (30 cm)	12 inches (30 cm)
B. Clearance to window or door that may be opened	12 inches (30 cm) for models <100,000 BTUH (30 kW), 36 inches (91 cm) for models > 100,000 BTUH (30 kW)	4 Feet
C. Clearance to permanently closed window	4 Feet	4 Feet
D. Vertical clearance to ventilated soffit located above the terminal within a horizontal distance of 2 feet (61 cm) from the center line of the terminal	4 Feet	4 Feet
E. Clearance to unventilated soffit	12 Inches	12 Inches
F. Clearance to outside corner	12 Inches	12 Inches
G. Clearance to inside corner	6 Feet	6 Feet
H. Clearance to each side of center line extended above meter/regulator assembly	3 feet (91 cm) within a height 15 feet (4.5 m) above the meter/regulator assembly	3 feet (91 cm) within a height 15 feet (4.5 m) above the meter/regulator assembly
I. Clearance to service regulator vent outlet	3 feet (91 cm)	3 feet (91 cm)
J. Clearance to nonmechanical air supply inlet to building or the combustion air inlet to any other appliance	12 inches (30 cm) for models <100,000 BTUH (30 kW), 35 inches (91 cm) for models >100,000 BTUH (30 kW)	4 Feet
K. Clearance to a mechanical supply inlet	6 feet (1.83 m)	3 feet (91 cm) above if within 10 feet (3 cm) horizontally
L. Clearance above paved sidewalk or paved driveway located on public property	7 feet (2.13 m) †	7 feet (2.13 m) †
M. Clearance under veranda, porch, deck, or balcony	12 inches (30.4 cm)	12 inches (30.4 cm)
Vent Termination from any Building Surface	12" (30.4 cm)	12" (30.4 cm)
Above anticipated snow depth	12" (30.4 cm)	12" (30.4 cm)

1. In accordance with the current CSA B149.1-00, Natural Gas and Propane Installation Code.

2. In accordance with the current ANSI Z223.1 / NFPA 54, National Gas Code.

† A vent shall not terminate directly above a sidewalk or paved driveway that is located between two single family dwellings and serves both dwellings.

‡ Permitted only if veranda, porch, deck, or balcony is fully open on a minimum of two sides beneath the floor. For clearance not specified in ANSI Z223.1 / NFPA 54 or CSA B149.1-00.

Clearance in accordance with local installation codes and the requirements of the gas supplier and the manufacturer's Installation Manual.

Any fresh air or make up inlet for dryer or furnace area is considered to be forced air inlet.

Avoid areas where condensate drippage may cause problems such as above planters, patios, or adjacent to windows where steam may cause fogging.

A terminus of a vent shall be either:

Fitted with a cap in accordance with the vent manufacturer's installation instructions, or In accordance with the installation instructions for a special venting system.

* Does not apply to multiple installations of this furnace model. Refer to "VENTING MULTIPLE UNITS" in this section of these instructions.

IMPORTANT: Consideration must be given for degradation of building materials by flue gases. Sidewall termination may require sealing or shielding of building surfaces with a corrosion resistant material to protect against combustion product corrosion. Consideration must be given to wind direction in order to prevent flue products and/or condensate from being blown against the building surfaces. If a metal shield is used it must be a stainless steel material at a minimum dimension of 20 inches. It is recommended that a retaining type collar be used that is attached to the building surface to prevent movement of the vent pipe.

Responsibility for the provision of proper adequate venting and air supply for application shall rest with the installer.

Vent shall extend high enough above building, or a neighboring obstruction, so that wind from any direction will not create a positive pressure in the vicinity of the vent.

HORIZONTAL VENT APPLICATIONS AND TERMINATION

When selecting the location for a horizontal combustion air / vent termination, the following should be considered:

1. Observe all clearances listed in vent clearances in these instructions.
2. Termination should be positioned where flue products will not damage plants or shrubs or air conditioning equipment.
3. Termination should be located where it will not be affected by wind gusts, light snow, airborne leaves or allow recirculation of flue gases.

4. Termination should be located where it will not be damaged or exposed to flying stones, balls, etc.
5. Termination should be positioned where vent vapors are not objectionable.
6. Horizontal portions of the vent system must slope upwards and be supported to prevent sagging. The vent system may be supported by the use of clamps or hangers secured to a permanent part of the structure every 4 ft. (1.22 m).

FAN-ASSISTED COMBUSTION SYSTEM

An appliance equipped with an integral mechanical means to either draw or force products of combustion through the combustion chamber and/or heat exchanger.

Ambient Combustion Air Supply

This type installation will draw the air required for combustion from within the space surrounding the appliance and from areas or rooms adjacent to the space surrounding the appliance. This may be from within the space in a non-confined location or it may be brought into the furnace area from outdoors through permanent openings or ducts. A single, properly sized pipe from the furnace vent connector to the outdoors must be provided. For upflow models combustion air is brought into the furnace through the unit top panel opening.

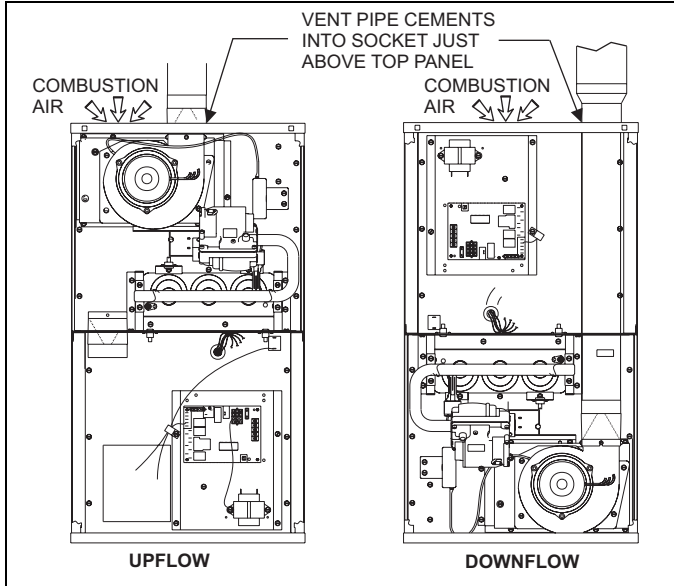

FIGURE 34: Combustion Airflow Path Through The Furnace Casing to the Burner Box

WARNING

This type of installation requires that the supply air to the appliance(s) be of a sufficient amount to support all of the appliance(s) in the area. Operation of a mechanical exhaust, such as an exhaust fan, kitchen ventilation system, clothes dryer or fireplace may create conditions requiring special attention to avoid unsatisfactory operation of gas appliances. A venting problem or a lack of supply air will result in a hazardous condition, which can cause the appliance to soot and generate dangerous levels of CARBON MONOXIDE, which can lead to serious injury, property damage and / or death.

An **unconfined space** is not less than 50 cu.ft (1.42 m³) per 1,000 Btu/hr (0.2928 kW) input rating for all of the appliances installed in that area.

Rooms communicating directly with the space containing the appliances are considered part of the unconfined space, if openings are furnished with doors.

A **confined space** is an area with less than 50 cu.ft (1.42 m³) per 1,000 Btu/hr (0.2928 kW) input rating for all of the appliances installed in that area. The following must be considered to obtain proper air for combustion and ventilation in confined spaces.

Combustion Air Source From Outdoors

The blocking effects of louvers, grilles and screens must be given consideration in calculating free area. If the free area of a specific louver or grille is not known, refer to Table 11, to estimate free area.

TABLE 11: Estimated Free Area

Wood or Metal Louvers or Grilles	Wood 20-25%* Metal 60-70% *
Screens+	1/4" (0.635 cm) mesh or larger 100%

* Do not use less than 1/4" (0.635 cm) mesh

+ Free area of louvers and grille varies widely; the installer should follow louver or grille manufacturer's instructions.

Dampers, Louvers and Grilles (Canada Only)

1. The free area of a supply air opening shall be calculated by subtracting the blockage area of all fixed louvers grilles or screens from the gross area of the opening.
2. Apertures in a fixed louver, a grille, or screen shall have no dimension smaller than 0.25" (0.635 cm).
3. A manually operated damper or manually adjustable louvers are not permitted for use.
4. A automatically operated damper or automatically adjustable louvers shall be interlocked so that the main burner cannot operate unless either the damper or the louver is in the fully open position.

TABLE 12: Free Area

BTUH Input Rating	Minimum Free Area Required for Each Opening		
	Horizontal Duct (2,000 BTUH)	Vertical Duct or Opening to Outside (4,000 BTUH)	Round Duct (4,000 BTUH)
60,000	30 in ² (193 cm ²)	15 in ² (97 cm ²)	5" (13 cm)
80,000	40 in ² (258 cm ²)	20 in ² (129 cm ²)	5" (13 cm)
100,000	50 in ² (322 cm ²)	25 in ² (161 cm ²)	6" (15 cm)
125,000	60 in ² (387 cm ²)	30 in ² (193 cm ²)	7" (18 cm)
150,000	75 in ² (484 cm ²)	37 in ² (239 cm ²)	7" (18 cm)

EXAMPLE: Determining Free Area.

Appliance	1Appliance	2Total Input
100,000	+ 30,000 = (130,000 ÷ 4,000) = 32.5 Sq. In.	Vertical
Appliance	1Appliance	2Total Input
100,000	+ 30,000 = (130,000 ÷ 2,000) = 65 Sq. In.	Horizontal

TABLE 13: Unconfined Space Minimum Area in Square Feet

BTUH Input Rating	Minimum Free Area Required for Each Opening
40,000	250 (23.23 m ²)
60,000	375 (34.84 m ²)
80,000	500 (46.45 m ²)
100,000	625 (58.06 m ²)
125,000	750 (69.68 m ²)
150,000	938 (87.14 m ²)

EXAMPLE: Square feet is based on 8 foot ceilings.

$$\frac{28,000 \text{ BTUH}}{1,000} \times 50 \text{ Cubic Ft.} = \frac{1,400}{8' \text{ Ceiling Height}} = 175 \text{ Sq. Ft.}$$

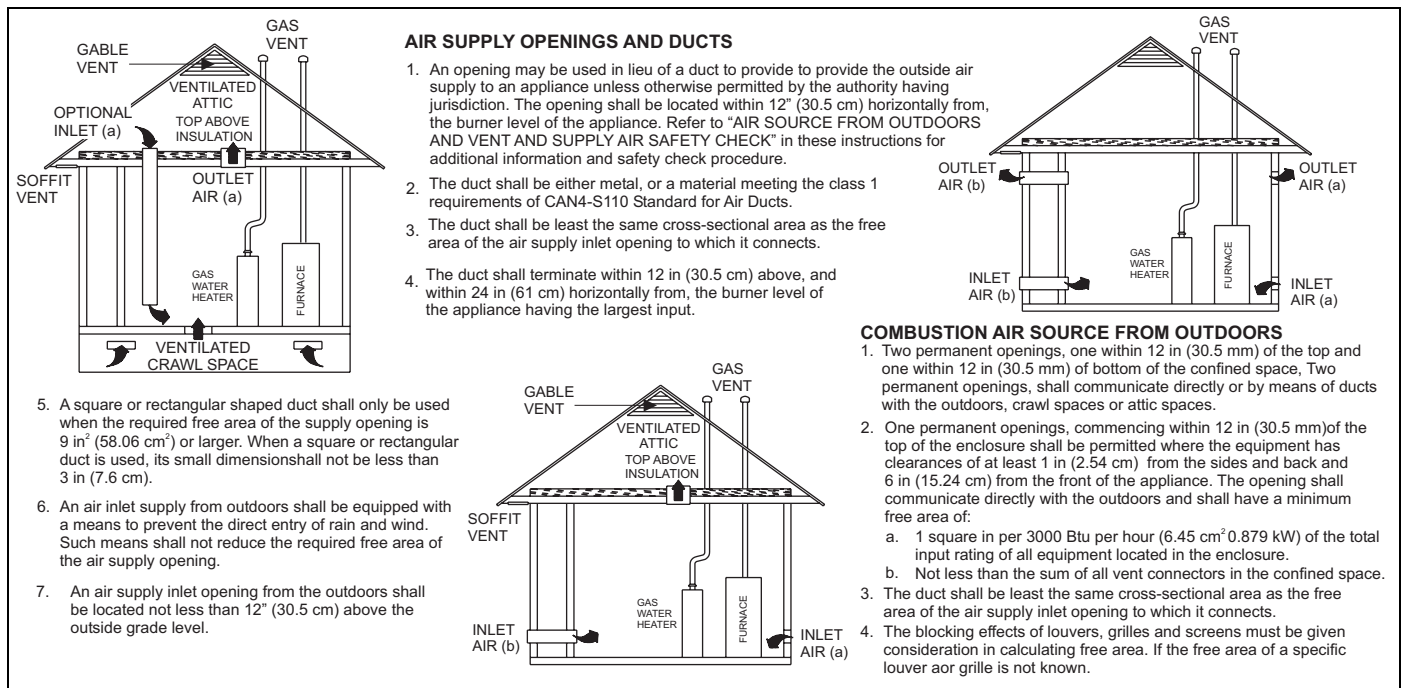

FIGURE 35: Outside and Ambient Combustion Air

WARNING

When a Category I furnace is removed or replaced, the original venting system may no longer be correctly sized to properly vent the attached appliances.

An improperly sized vent system can cause CARBON MONOXIDE to spill into the living space causing personal injury, and or death.

Ventilated Combustion Air

The ventilated attic space or a crawl space from which the combustion air is taken must comply with the requirements specified in "AIR SOURCE FROM OUTDOORS" in this instruction or in Section 5.3, Air for Combustion and Ventilation of the National Fuel Gas Code, ANSI Z223.1 (latest edition). This type installation requires a pipe that extends from the furnace vent connection (top right of unit) to the exterior of the building. Follow all notes, procedures and required materials in the COMBUSTION AIR SUPPLY section in these instructions when installing the unit and into a ventilated attic space or crawl space. DO NOT terminate vent pipe in an Attic or Crawl Space.

Vent and Supply (Outside) Air Safety Check Procedure

For Category I furnaces, vent installations shall be in accordance with Parts 7 and 11 of the National Fuel Gas Code, ANSI Z223.1/NFPA 54, and or Section 7 and Appendix B of the CSA B149.1, Natural Gas and Propane Installation Codes, the local building codes, furnace and vent manufacture's instructions.

Multistory or common venting systems are permitted and must be installed in accordance with the National Fuel Gas Code, ANSI Z223.1/NFPA 54 and / or the CSA B149.1, Natural Gas and Propane Installation Codes, local codes, and the manufacture's instructions.

Vent connectors serving Category I furnaces shall not be connected into any portion of mechanical draft systems operating under positive pressure.

Horizontal portions of the venting system shall be supported to prevent sagging using hangers or perforated straps and must slope upwards not less than 1/4" per foot (0.635 cm/m) from the furnace to the vent terminal.

It is recommended that you follow the venting safety procedure below. This procedure is designed to detect an inadequate ventilation system that can cause the appliances in the area to operate improperly causing unsafe levels of Carbon Monoxide or an unsafe condition to occur.

▲ WARNING

CARBON MONOXIDE POISONING HAZARD

Failure to follow the steps outlined below for each appliance connected to the venting system being placed into operation could result in carbon monoxide poisoning or death.

The following steps shall be followed for each appliance connected to the venting system being placed into operation, while all other appliances connected to the venting system are not in operation:

1. Inspect the venting system for proper size and horizontal pitch. Determine that there is no blockage, restriction, leakage, corrosion or other deficiencies, which could cause an unsafe condition
2. Close all building doors and windows and all doors.
3. Turn on clothes dryers and TURN ON any exhaust fans, such as range hoods and bathroom exhausts, so they shall operate at maximum speed. Open the fireplace dampers. Do not operate a summer exhaust fan.
4. Follow the lighting instructions. Place the appliance being inspected in operation. Adjust thermostat so the appliance shall operate continuously.
5. Test each appliance (such as a water heater) equipped with a draft hood for spillage (down-draft or no draft) at the draft hood relief opening after 5 minutes of main burner operation. Appliances that do not have draft hoods need to be checked at the vent pipe as close to the appliance as possible. Use a combustion analyzer to check the CO₂ and CO levels of each appliance. Use a draft gauge to check for a downdraft or inadequate draft condition.
6. After it has been determined that each appliance properly vents when tested as outlined above, return doors, windows, exhaust fans, fireplace dampers and any other gas burning appliance to their normal condition.
7. If improper venting is observed during any of the above tests, a problem exists with either the venting system or the appliance does not have enough combustion air (Supply Air from outside) to complete combustion. This condition must be corrected before the appliance can function safely.

NOTE: An unsafe condition exists when the CO reading at the furnace vent exceeds 40 ppm and the draft reading is not in excess of - 0.1 in. W.C. (-25 kPa) with all of the appliance(s) operating at the same time.

8. Any corrections to the venting system and / or to the supply (outside) air system must be in accordance with the National Fuel Gas Code Z223.1 or CAN/CGA B149.1-00 Natural Gas and Propane Installation Code (latest editions). If the vent system must be resized, follow the appropriate tables in Appendix G of the above codes or for this appliance.

SECTION IX: SAFETY CONTROLS

CONTROL CIRCUIT FUSE

A 3-amp fuse is provided on the control circuit board to protect the 24-volt transformer from overload caused by control circuit wiring errors. This is an ATO 3, automotive type fuse and is located on the control board.

BLOWER DOOR SAFETY SWITCH

This unit is equipped with an electrical interlock switch mounted in the blower compartment. This switch interrupts all power at the unit when the panel covering the blower compartment is removed.

Electrical supply to this unit is dependent upon the panel that covers the blower compartment being in place and properly positioned.

▲ CAUTION

Main power to the unit must still be interrupted at the main power disconnect switch before any service or repair work is to be done to the unit. Do not rely upon the interlock switch as a main power disconnect.

Blower and burner must never be operated without the blower panel in place.

ROLLOUT SWITCH CONTROLS

These controls are mounted on the burner box assembly. If the temperature in the burner box exceeds its set point, the ignition control and the gas valve are de-energized. The operation of this control indicates a malfunction in the combustion air blower, heat exchanger or a blocked vent pipe connection. Corrective action is required. These are manual reset controls that must be reset before operation can continue.

PRESSURE SWITCHES

This furnace is supplied with a pressure switch, which monitors the flow through the combustion air/vent piping system. This switch de-energizes the ignition control module and the gas valve if any of the following conditions are present. Refer to Figure 36 for tubing connections.

1. Blockage of combustion air piping or terminal.

2. Blockage of vent piping or terminal.
3. Failure of combustion air blower motor.

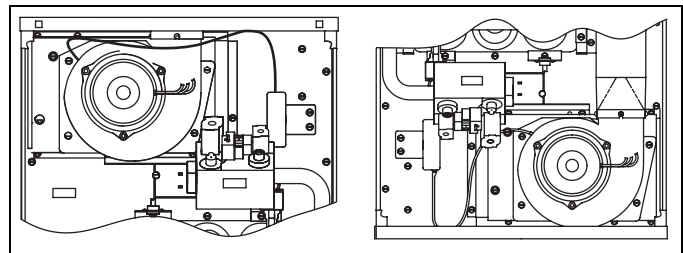

FIGURE 36: Pressure Switch Tubing Routing

LIMIT CONTROLS

There is high temperature limit control located on the furnace vestibule panel near the gas valve. This is an automatic reset control that provides over temperature protection due to reduced airflow, that may be caused by a dirty filter, or if the indoor fan motor should fail. The control module will lockout if the limit trips 3 consecutive times. Control will reset and try ignition again after 1 hour.

SECTION X: START-UP AND ADJUSTMENTS

The initial start-up of the furnace requires the following additional procedures:

IMPORTANT: All electrical connections made in the field and in the factory should be checked for proper tightness.

When the gas supply is initially connected to the furnace, the gas piping may be full of air. In order to purge this air, it is recommended that the ground union be loosened until the odor of gas is detected. When gas is detected, immediately retighten the union and check for leaks. Allow five minutes for any gas to dissipate before continuing with the start-up procedure. Be sure proper ventilation is available to dilute and carry away any vented gas.

TOOLS AND INFORMATION THAT WILL BE REQUIRED IN ORDER TO PROPERLY PERFORM THE FURNACE STARTUP PROCEDURE.

1. Call the local gas supplier to obtain heating value of the natural gas. If you cannot obtain the heating value of the gas from the gas supplier, you may use a default value of 1030 BTU/SCF (38.8 MJ / m³).
2. You will need a thermometer or portable digital thermometer to read the supply and return air temperatures.
3. You will need a U-tube manometer or digital equipment that has the ability to read pressures between 0 – 15" in.w.c (0 - 3.73 kPa) in order to measure the gas line and the manifold pressures.
4. You will need a 3/32" Allen wrench for the pressure port plugs in the gas valve.
5. You will need 2 pieces of 1/8" (0.3 cm) ID flexible tubing that is 12" (30 cm) in length, 2 – pieces of 1/8" (0.3 cm) tubing that are 4" (10.0 cm) in length, a 1/8" (0.3 cm) tee and a 1/8" (0.3 cm) adapter to connect the U-tube manometer or the digital pressure measuring equipment to the gas valve pressure ports.

There is an accessory kit (1PK0601) available from Source 1, which has the following items:

- 1 - 12" (30 cm) length x 1/8" (0.3 cm) diameter tubing
- 2 – pieces of 4" (10 cm) length x 1/8" (0.3 cm) diameter tubing
- 1 - 5/16" (0.8 cm) tee
- 1 – 5/16" (0.8 cm) x 1/8" (0.3 cm) reducing coupling
- 1 – 1/8" (0.3 cm) adapter

There is a accessory kit (1PK0602) available from Source 1, which has the following items:

- 12" (30 cm) length x 1/8" (0.3 cm) diameter tubing
- 2 – pieces of 4" (10 cm) length x 1/8" (0.3 cm) diameter tubing
- 1 - 5/16" (0.8 cm) tee
- 1 – 5/16" (0.8 cm) x 1/8" (0.3 cm) reducing coupling
- 1 – 1/8" (0.3 cm) adapter
- 1 - Dwyer – Manometer

These items are required in order to properly perform the required start-up procedure.

IGNITION SYSTEM SEQUENCE

1. Turn the gas supply ON at external valve and main gas valve.
2. Set the thermostat above room temperature to call for heat.
3. System start-up will occur as follows:
 - a. The induced draft blower motor will start and come up to speed. Shortly after inducer start-up, the hot surface ignitor will glow for about 17 seconds.

- b. After this warm up, the ignition module will energize (open) the main gas valve.
- c. After flame is established, the supply air blower will start in about 30 seconds.

WARNING

FIRE OR EXPLOSION HAZARD

Failure to follow the safety warnings exactly could result in serious injury, death or property damage.

Never test for gas leaks with an open flame. Use a commercially available soap solution made specifically for the detection of leaks to check all connections. A fire or explosion may result causing property damage, personal injury or loss of life.

IMPORTANT: Burner ignition may not be satisfactory on first startup due to residual air in the gas line or until gas manifold pressure is adjusted. The ignition control will make 3 attempts to light before locking out.

With furnace in operation, check all of the pipe joints, gas valve connections and manual valve connections for leakage using an approved gas detector, a non-corrosive leak detection fluid, or other leak detection methods. Take appropriate steps to stop any leak. If a leak persists, replace the component.

The furnace and its equipment shutoff valve must be disconnected from the gas supply piping system during any pressure testing of that system at test pressures in excess of 1/2 PSI (3.45 kPa).

The furnace must be isolated from the gas supply piping system by closing the equipment shutoff valve during any pressure testing of the gas supply piping system.

CALCULATING THE FURNACE INPUT (NATURAL GAS)

NOTE: Burner orifices are sized to provide proper input rate using natural gas with a heating value of 1030 BTU/Ft³. If the heating value of your gas is significantly different, it may be necessary to replace the orifices.

1. Turn off all other gas appliances connected to the gas meter.
2. At the gas meter, measure the time (with a stop watch) it takes to use 2 cubic ft. (0.0566 m³.) of gas.
3. Calculate the furnace input by using one of the following equations.

TABLE 14: Field Installed Accessories - Non Electrical

PART NO.	DESCRIPTION	USED WITH
1FB0318	Combustible Floor Sub-Base	50, 7512
1FB0319		7516,10016
1FB0320		10020,125
1BR0312	Bottom Filter Rack	50,7512
1BR0316		7516,10016
1BR0320		10020,125,150
1NP0366	Conversion Kit-Natural Gas to LP Gas	All Models
1NP0367	Conversion Kit- Natural Gas to LP Gas- High Altitude	
2802-321P	Vent Pipe Extension	

In the USA use the following formula to calculate the furnace input.

For natural gas multiply the heat content of the gas BTU/SCF (or Default 1030 BTU/SCF, times 2 cubic ft. of gas measured at the gas meter, times a barometric pressure and temperature correction factor of 0.960; times 3600, then divided by the time (In seconds) it took to measure 2 cubic ft. of gas from the gas meter.

For propane (LP) gas multiply the heat content of the gas BTU/SCF (or Default 2500 BTU/SCF, times 1 cubic ft. of gas measured at the gas meter, times a barometric pressure and temperature correction factor of 0.960; times 3600, then divided by the time (In seconds) it took to measure 1 cubic ft. of gas from the gas meter.

The formula for US input calculation using a cubic foot gas meter:

$\frac{\text{BTU/ft}^3 \times 2 \text{ cu.ft.} \times 0.960 \times 3600}{\text{Seconds it took to measure the 2 cu.ft. of gas}}$ = BTUH/H	$\frac{\text{BTU/ft}^3 \times 1 \text{ cu.ft.} \times 0.960 \times 3600}{\text{Seconds it took to measure the 2 cu.ft. of gas}}$ = BTUH/H
NATURAL GAS INPUT CALCULATION EXAMPLE: $\frac{1030 \times 2 \times 0.960 \times 3600}{90.5} = 79,997.38$ Natural Gas BTU/SCF 1030	PROPANE (LP) GAS INPUT CALCULATION EXAMPLE: $\frac{2500 \times 1 \times 0.960 \times 3600}{108} = 80,000.00$ Propane Gas BTU/SCF 2500

In Canada you will use the following formula to calculate the furnace input if you are using a cubic foot gas meter.

For Natural Gas multiply the Heat content of the gas MJ/m³ (or Default 39.2), times 2 cu. ft. of gas x 0.02831 to convert from cubic feet to cubic meters measured at the gas meter, times a barometric pressure and temperature correction factor of 0.960; times 3600, then divided by the time it took to measure 2 cu.ft. of gas from the gas meter.

For Propane (LP) Gas multiply the Heat content of the gas MJ/m³ (or Default 93.14), times 1 cu. ft. of gas x 0.02831 to convert from cubic feet to cubic meters measured at the gas meter, times a barometric pressure and temperature correction factor of 0.960; times 3600, then divided by the time it took to measure 1 cu.ft. of gas from the gas meter.

The formula for metric input calculation using a cubic foot gas meter:

$\frac{\text{MJ/m}^3 \times (2 \text{ cu.ft.} \times \text{Conv}) \times 0.960 \times 3600}{\text{Seconds it took to measure the 2 cu.ft. of gas}}$ = MJ/H x 0.2777 = kW x 3412.14 = BTUH/H
NATURAL GAS INPUT CALCULATION EXAMPLE: $\frac{39.2 \times 2 \times 0.960 \times 3600}{90.5} = 84.76 \times 0.2777 = 23.54 \times 3412.14 = 80,312.62$ Natural Gas BTU/SCF 1030 = 39.2 MJ/m ³
PROPANE (LP) GAS INPUT CALCULATION EXAMPLE: $\frac{93.15 \times 1 \times 0.960 \times 3600}{108} = 84.41 \times 0.2777 = 23.45 \times 3412.14 = 80,000.00$ Propane Gas BTU/SCF 2500+93.15 MJ/m ³

In Canada use the following formula to calculate the furnace input if you are using a gas meter that measures cubic meters.

For Natural Gas multiply the Heat content of the gas MJ/m³ (or Default 39.2), times 0.0566 m³ of gas measured at the gas meter, times a barometric pressure and temperature correction factor of 0.960; times 3600, then divided by the time it took to measure 0.0566 m³ of gas from the gas meter.

For Propane (LP) Gas multiply the Heat content of the gas MJ/m³ (or Default 93.14), times 0.00283 m³ of gas measured at the gas meter, times a barometric pressure and temperature correction factor of 0.960; times 3600, then divided by the time it took to measure 0.0283 cm of gas from the gas meter.

The formula for metric input calculation using a cubic foot gas meter:

$\frac{\text{MJ/m}^3 \times (2 \text{ cu.ft.} \times \text{Conv}) \times 0.960 \times 3600}{\text{Seconds it took to measure the 2 cu.ft. of gas}}$ = MJ/H x 0.2777 = kW x 3412.14 = BTUH/H
NATURAL GAS INPUT CALCULATION EXAMPLE: $\frac{39.2 \times 2 \times 0.960 \times 3600}{90.5} = 84.76 \times 0.2777 = 23.54 \times 3412.14 = 80,312.62$ Natural Gas BTU/SCF 1030 = 39.2 MJ/m ³
PROPANE (LP) GAS INPUT CALCULATION EXAMPLE: $\frac{93.15 \times 1 \times 0.960 \times 3600}{108} = 84.41 \times 0.2777 = 23.45 \times 3412.14 = 80,000.00$ Propane Gas BTU/SCF 2500+93.15 MJ/m ³

DO NOT ADJUST the manifold pressure regulator if the actual input is equal to or within 8% less than the furnace input specified on the rating plate or if the furnace rise is above the specified rise range on the rating plate.

If the actual input is significantly higher than the furnace input specified on the rating plate then replace the gas orifice spuds with the gas orifice spuds of the proper size for the type of gas you are using.

CAUTION

Be sure to relight any gas appliances that were turned off at the start of this input check.

TABLE 15: Inlet Gas Pressure Range

INLET GAS PRESSURE RANGE		
	Natural Gas	Propane (LP)
Minimum	4.5" W.C. (1.12 kPa)	8.0" W.C. (1.99 kPa)
Maximum	10.5" W.C. (2.61 kPa)	13.0" (3.24 kPa) W.C.

IMPORTANT: The inlet gas pressure operating range table specifies what the minimum and maximum gas line pressures must be for the furnace to operate safely. The gas line pressure **MUST BE** a minimum of

- 7" W.C. (1.74 kPa) for Natural Gas
- 11" W.C. (2.74 kPa) for Propane (LP) Gas

in order to obtain the BTU input specified on the rating plate and in these instructions.

ADJUSTMENT OF MANIFOLD GAS PRESSURE

Manifold gas pressure may be measured at the gas valve.

Turn gas off at the ball valve or gas cock on gas supply line before the gas valve. Find the pressure ports on the gas valve marked OUT P and IN P.

1. The manifold pressure must be taken at the port marked OUT P.
2. The gas line pressure must be taken at the port marked IN P.
3. Using a 3/32" Allen wrench, loosen the setscrew by turning it 1 turn counter clockwise. DO NOT REMOVE THE SET SCREW FROM THE PRESSURE PORT.
4. Use the 4" (10.2 cm) piece of 1/8" (0.3 cm) tubing to connect the positive side of the manometer to the gas valve pressure reference port. Refer to Figure 38 for connection details.

IMPORTANT: The cap for the pressure regulator must be removed entirely to gain access to the adjustment screw. Loosening or tightening the cap does not adjust the flow of gas.

5. Refer to Figure 37 for location of pressure regulator adjustment cap and adjustment screw on main gas valve.
6. Turn gas and electrical supplies on and follow the operating instructions to place the unit back in operation.
7. Adjust manifold pressure by adjusting gas valve regulator screw for the appropriate gas per the following:

TABLE 16: Nominal Manifold Pressure

NOMINAL MANIFOLD PRESSURE	
Natural Gas	3.5" w.c. (0.87 kPa)
Propane (LP) Gas	10.0" w.c. (2.488 kPa)

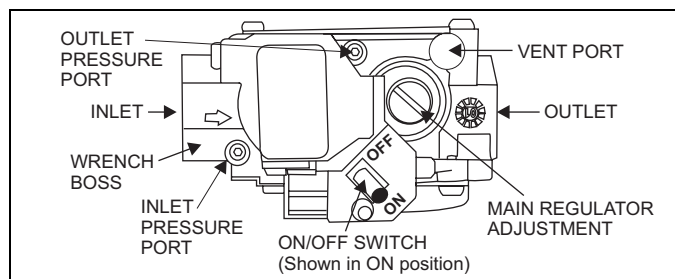

FIGURE 37: Gas Valve

IMPORTANT: If gas valve regulator is turned in (clockwise), manifold pressure is increased. If screw is turned out (counterclockwise), manifold pressure will decrease.

8. After the manifold pressure has been adjusted, re-calculate the furnace input to make sure you have not exceeded the specified input on the rating plate. Refer to "CALCULATING THE FURNACE INPUT (NATURAL GAS)".

9. Once the correct BTU (kW) input has been established, turn the gas valve to OFF and turn the electrical supply switch to OFF; then remove the flexible tubing and fittings from the gas valve pressure tap and tighten the pressure tap plug using the 3/32" Allen wrench.
10. Turn the electrical and gas supplies back on, and with the burners in operation, check for gas leakage around the gas valve pressure port for leakage using an approved gas detector, a non-corrosive leak detection fluid, or other leak detection methods.

WARNING

The manifold pressure must be checked with the screw-off cap for the gas valve pressure regulator in place. If not, the manifold pressure setting could result in an over-fire condition. A high manifold pressure will cause an over-fire condition, which could cause premature heat exchanger failure. If the manifold pressure is too low, sooting and eventual clogging of the heat exchanger could occur. Be sure that gas valve regulator cap is in place and burner box to gas valve pressure reference hose is connected.

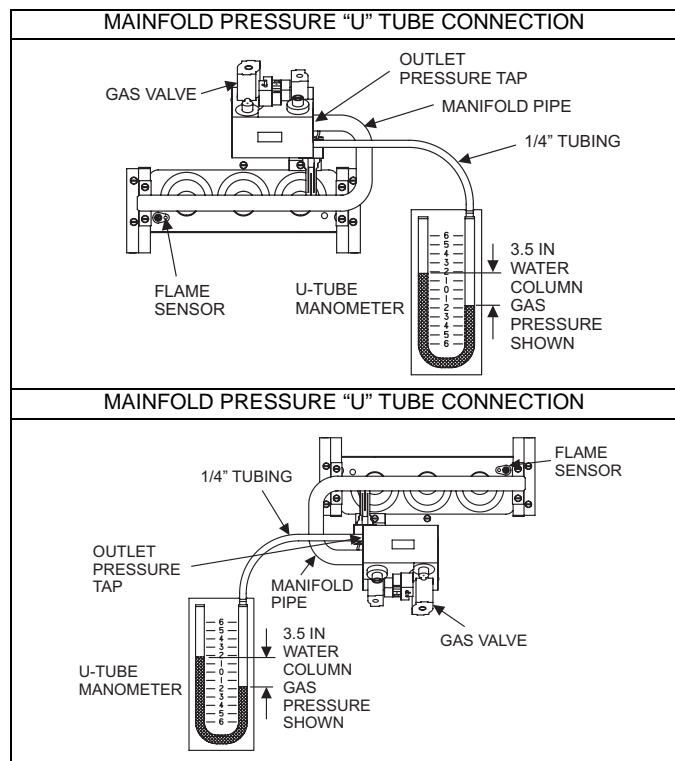

FIGURE 38: Reading Gas Pressure

ADJUSTMENT OF TEMPERATURE RISE

DANGER

The temperature rise, or temperature difference between the return air and the supply (heated) air from the furnace, must be within the range shown on the furnace rating plate and within the application limitations shown in Table 8 "ELECTRICAL AND PERFORMANCE DATA".

The supply air temperature cannot exceed the "Maximum Supply Air Temperature" specified in these instructions and on the furnace rating plate. Under NO circumstances can the furnace be allowed to operate above the Maximum Supply Air Temperature. Operating the furnace above the Maximum Supply Air Temperature will cause premature heat exchanger failure, high levels of Carbon Monoxide, a fire hazard, personal injury, property damage, and/or death.

The temperature rise, or temperature difference between the return air and the heated supply air from the furnace, must be within the range shown on the furnace rating plate and within the application limitations as shown in Table 8.

After about 15 minutes of operation, determine the furnace temperature rise. Take readings of both the return air and the heated air in the ducts, about six feet (1.83 m) from the furnace where they will not be affected by radiant heat. Increase the blower speed to decrease the temperature rise; decrease the blower speed to increase the rise.

All direct-drive blowers have multi-speed motors. The blower motor speed taps are located in the control box in the blower compartment. Refer to Figure 39, and the unit wiring label to change the blower speed. To use the same speed tap for heating and cooling, the heat terminal and cool terminal must be connected using a jumper wire and connected to the desired motor lead. Place all unused motor leads on Park terminals. Two are provided.

CAUTION

Do not energize more than one motor speed at a time or damage to the motor will result.

ADJUSTMENT OF FAN CONTROL SETTINGS

This furnace is equipped with a time-on/time-off heating fan control. The fan on delay is fixed at 30 seconds. The fan off delay has 4 settings (60, 90, 120 and 180 seconds). The fan off delay is factory set to 120 seconds. The fan-off setting must be long enough to adequately cool the furnace, but not so long that cold air is blown into the heated space. The fan-off timing may be adjusted by positioning the jumper on two of the four pins as shown in Figure 39.

TABLE 17: Filter Performance - Pressure Drop Inches W.C. and (kPa)

Airflow Range		Minimum Opening Size				Filter Type											
						Disposable				Hogs Hair*				Pleated			
		1 Opening		2 Openings		1 Opening		2 Openings		1 Opening		2 Openings		1 Opening		2 Openings	
CFM	Cm/m	In ³	m ³	In ³	m ³	inwc	kPa	inwc	kPa	inwc	kPa	inwc	kPa	inwc	kPa	inwc	kPa
0 - 750	0 - 21.24	230	0.0038			0.01	0.0025			0.01	0.0025			0.15	0.0374		
751 - 1000	21.27 - 28.32	330	0.0054			0.05	0.0125			0.05	0.0125			0.2	0.0498		
1001 - 1250	28.35 - 35.40	330	0.0054			0.1	0.0249			0.1	0.0249			0.2	0.0498		
1251 - 1500	35.42 - 42.47	330	0.0054			0.1	0.0249			0.1	0.0249			0.25	0.0623		
1501 - 1750	42.50 - 49.55	380	0.0062			0.15	0.0374			0.14	0.0349			0.3	0.0747		
1751 - 2000	49.58 - 56.63	380	0.0062	658	0.0108	0.19	0.0473	0.11	0.0274	0.18	0.0448	0.1	0.0249	0.3	0.0747	0.17	0.0423
2001 & Above	56.66 & Above	463	0.0076	658	0.0108	0.19	0.0473	0.11	0.0274	0.18	0.0448	0.1	0.0249	0.3	0.0747	0.17	0.0423

* Hogs Hair Filters are the type supplied with furnace (if supplied).

APPLYING FILTER PRESSURE DROP TO DETERMINE SYSTEM AIRFLOW

To determine the approximate airflow of the unit with a filter in place, follow the steps below:

1. Select the filter type.
2. Select the number of return air openings or calculate the return opening size in square inches to determine the proper filter pressure drop.
3. Determine the External System Static Pressure (ESP) without the filter.
4. Select a filter pressure drop from the table based upon the number of return air openings or return air opening size and add to the ESP from Step 3 to determine the total system static.
5. If total system static matches a ESP value in the airflow table (i.e. 0.20 w.c. (50 Pa), 0.60 w.c. (150 Pa), etc.,) the system airflow corresponds to the intersection of the ESP column and Model/Blower Speed row.
6. If the total system static falls between ESP values in the table (i.e. 0.58 w.c. (144 Pa), 0.75 w.c. (187 Pa), etc.), the static pressure may be rounded to the nearest value in the table determining the airflow using Step 5 or calculate the airflow by using the following example.

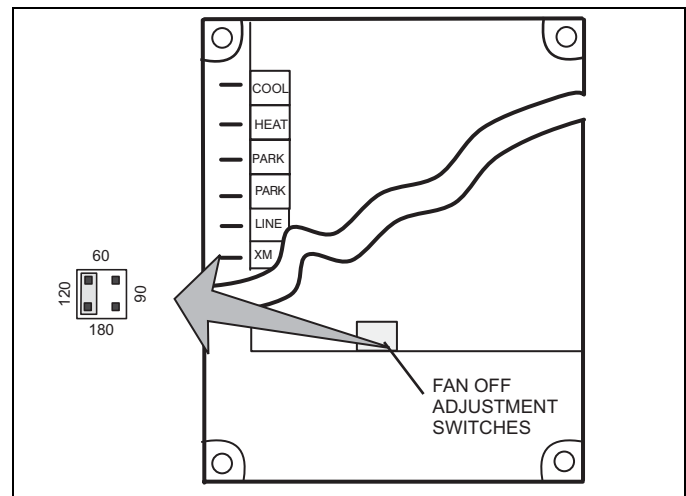

FIGURE 39: Typical Heat/Cool Speed Tap Connections

FILTER PERFORMANCE

The airflow capacity data published in Table 17 represents blower performance WITHOUT filters. To determine the approximate blower performance of the system, apply the filter drop value for the filter being used or select an appropriate value from the Table 16.

The filter pressure drop values in Table 16 are typical values for the type of filter listed and should only be used as a guideline. Actual pressure drop ratings for each filter type vary between filter manufacturers.

Example: For a 75,000 BTUH (21.98 kW) furnace with 2 return openings and operating on high-speed blower, it is found that total system static is 0.38" w.c. To determine the system airflow, complete the following steps:

Obtain the airflow values at 0.30 w.c. (75 Pa) & 0.40 w.c. (99.6 Pa) ESP.

Airflow @ 0.30": 1408 CFM (39.8 m³/min)

Airflow @ 0.40": 1343 CFM (38.0 m³/min)

Subtract the airflow @ 0.30 w.c. (75 Pa) from the airflow @ 0.40 w.c. (199.6 Pa) to obtain airflow difference.

1343 - 1408 = -65 CFM (1.89 m³/min)

Subtract the total system static from 0.30 w.c. (75 Pa) and divide this difference by the difference in ESP values in the table, 0.40 w.c. (99.6 Pa) - 0.30 w.c. (75 Pa), to obtain a percentage.

(0.38 - 0.30) / (0.40 - 0.30) = 0.8

Multiply percentage by airflow difference to obtain airflow reduction.

(0.8) X (-65) = -52

Subtract airflow reduction value to airflow @ 0.30 w.c. (75 Pa) to obtain actual airflow @ 0.38 inwc (94.6 Pa) ESP.

1408 - 52 = 1356

SECTION XI: WIRING DIAGRAM

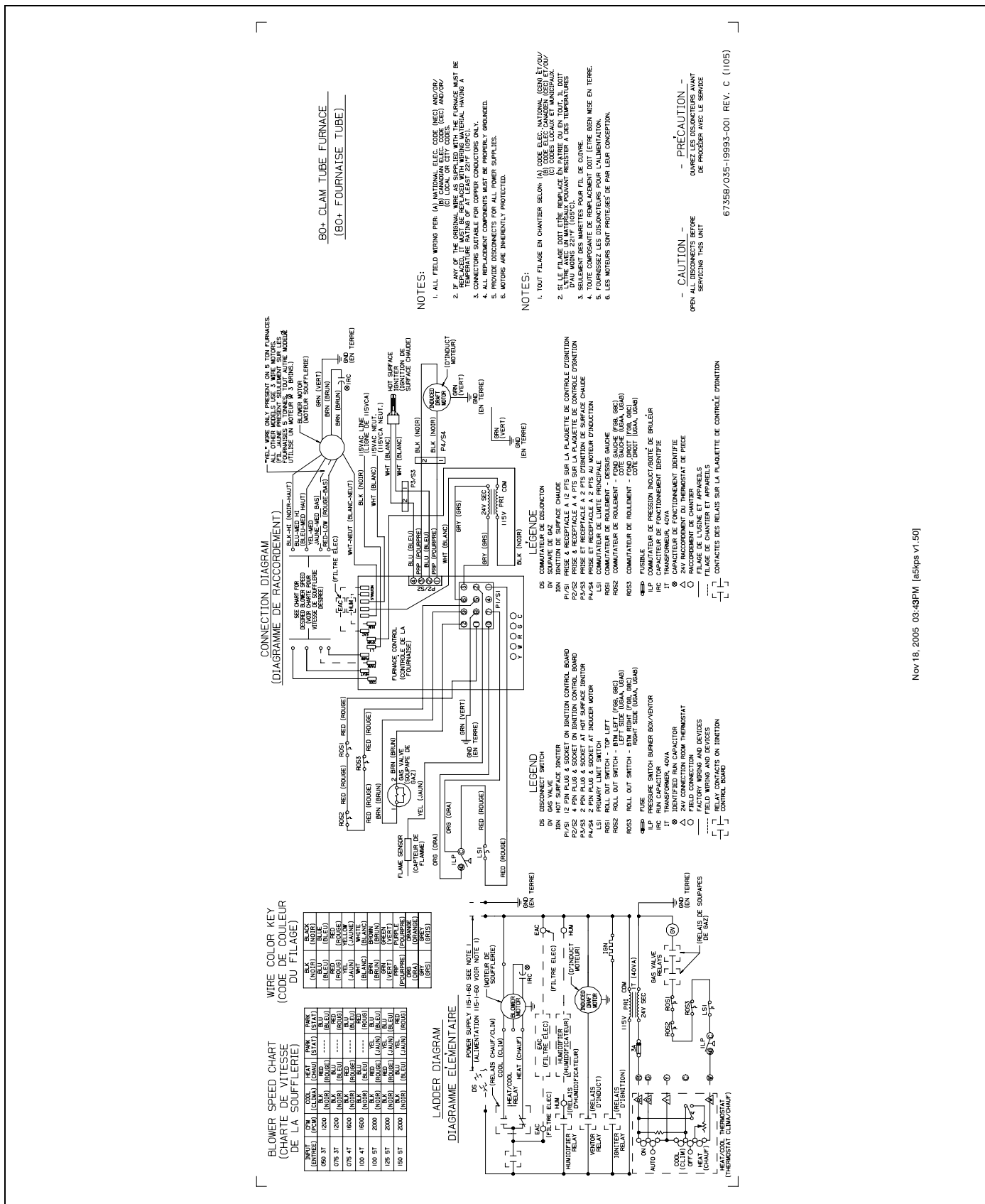

FIGURE 40: Wiring Diagram

Subject to change without notice. Printed in U.S.A. Copyright © by York International Corp. 2005. All rights reserved.

68632-UIM-D-1205 Supersedes: 68632/035-19991-001 Rev. C (0805)