

# INSTALLATION MANUAL

## HIGH EFFICIENCY TUBULAR HEAT EXCHANGER SERIES

MODELS: GM9T  
(Two Stage Upflow)

40 - 120 MBH INPUT  
(11.7 - 35.1 KW) INPUT



ISO 9001  
Certified Quality  
Management System

### LIST OF SECTIONS

SAFETY .....	1	COMBUSTION AIR AND VENT SYSTEM .....	12
DUCTWORK .....	3	CONDENSATE PIPING .....	18
FILTERS .....	6	SAFETY CONTROLS .....	19
GAS PIPING .....	6	START-UP AND ADJUSTMENTS .....	19
ELECTRICAL POWER .....	8	WIRING DIAGRAM .....	26

### LIST OF FIGURES

Dimensions .....	5	Double Horizontal Sealed Combustion Air and Vent Termination .....	16
Furnace Base Rectangular Blockoff Panel .....	6	Double Vertical Sealed Combustion Air and Vent Termination .....	16
Gas Valve .....	6	Sealed Combustion Air Intake Connection and Vent Connection .....	16
Gas Piping .....	6	Combustion Airflow Path Through The Furnace Casing .....	16
Electrical Wiring .....	9	Outside and Ambient Combustion Air .....	17
Thermostat Chart - AC .....	10	Attic and Crawl Space Combustion Air Termination .....	18
Thermostat Chart - HP .....	11	Condensate Piping .....	18
Accessory Connections .....	12	Pressure Switch Tube Routing .....	19
Home Layout .....	14	Gas Valve .....	22
Termination Configuration - 1 Pipe .....	15	Reading Gas Pressure .....	23
Termination Configuration - 2 Pipe .....	15	Furnace Control Board .....	23
Termination Configuration - 2 Pipe Basement .....	15	Wiring Diagram .....	26

### LIST OF TABLES

Unit Clearances to Combustibles .....	3	Combustion Air Supply and Vent Piping .....	13
Minimum Duct Sizing For Proper Airflow .....	4	Estimated Free Area .....	17
Round Duct Size .....	4	Free Area .....	17
Recommended Filter Sizes .....	6	Unconfined Space Minimum Area in Square Inch .....	17
Nominal Manifold Pressure - High Fire .....	7	Inlet Gas Pressure Range .....	22
Nominal Manifold Pressure - Low Fire .....	7	Nominal Manifold Pressure .....	22
Electrical and Performance Data .....	8	Blower Performance CFM .....	24
Combustion Air Intake and Vent Connection Size at Furnace (All Models) .....	12	Filter Performance - Pressure Drop Inches W.C. and (kPa) .....	24
		Field Installed Accessories - Non Electrical .....	25

## SECTION I: SAFETY



This is a safety alert symbol. When you see this symbol on labels or in manuals, be alert to the potential for personal injury.

Understand and pay particular attention to the signal words **DANGER**, **WARNING**, or **CAUTION**.

**DANGER** indicates an **imminently** hazardous situation, which, if not avoided, **will result in death or serious injury**.

**WARNING** indicates a **potentially** hazardous situation, which, if not avoided, **could result in death or serious injury**.

**CAUTION** indicates a potentially hazardous situation, which, if not avoided **may result in minor or moderate injury**. It is also used to alert against unsafe practices and hazards involving only property damage.

### WARNING

*Improper installation may create a condition where the operation of the product could cause personal injury or property damage.*

*Improper installation, adjustment, alteration, service or maintenance can cause injury or property damage. Refer to this manual for assistance or for additional information, consult a qualified contractor, installer or service agency.*

### CAUTION

*This product must be installed in strict compliance with the installation instructions and any applicable local, state, and national codes including, but not limited to building, electrical, and mechanical codes.*

## SPECIFIC SAFETY RULES AND PRECAUTIONS

1. Only Natural gas or Propane (LP) gas are approved for use with this furnace. Refer to the furnace rating plate or Section IV of these instructions.
2. Install this furnace only in a location and position as specified in SECTION I of these instructions.
3. A gas-fired furnace for installation in a residential garage must be installed as specified in SECTION I of these instructions.
4. Provide adequate combustion and ventilation air to the furnace space as specified in SECTION VI of these instructions.
5. Combustion products must be discharged outdoors. Connect this furnace to an approved vent system only, as specified in SECTION VI of these instructions.

### **WARNING**

#### **FIRE OR EXPLOSION HAZARD**

*Failure to follow the safety warnings exactly could result in serious injury, death or property damage.*

*Never test for gas leaks with an open flame. Use a commercially available soap solution made specifically for detection of leaks to check all connections. A fire or explosion may result causing property damage, personal injury or loss of life.*

6. Tests for gas leaks as specified in SECTION XI of these instructions.
7. Always install the furnace to operate within the furnace's intended temperature rise range. Only connect the furnace to a duct system which has an external static pressure within the allowable range, as specified on the furnace rating plate.
8. When a furnace is installed so that supply ducts carry air circulated by the furnace to areas outside the space containing the furnace, the return air shall also be handled by duct(s) sealed to the furnace casing and terminating outside the space containing the furnace.
9. The furnace is not to be used for temporary heating of buildings or structures under construction.
10. When installed in a Non-HUD-Approved Modular Home or building constructed on-site, combustion air shall not be supplied from occupied spaces.
11. The size of the unit should be based on an acceptable heat loss calculation for the structure. ACCA, Manual J or other approved methods may be used.

## SAFETY REQUIREMENTS

- This furnace should be installed in accordance with all national and local building/safety codes and requirements, local plumbing or wastewater codes, and other applicable codes. In the absence of local codes, install in accordance with the National Fuel Gas Code ANSI Z223.1/NFPA 54, National Fuel Gas Code, and/or CAN/CGA B149.1 Natural Gas and Propane Installation Code (latest editions). Furnaces have been certified to the latest edition of standard ANSI Z21-47 • CSA 2.3.
- Refer to the unit rating plate for the furnace model number, and then see the dimensions page of this instruction for return air plenum dimensions in Figure 1. The plenum must be installed according to the instructions.
- Provide clearances from combustible materials as listed under Clearances to Combustibles in Table 1.
- Provide clearances for servicing ensuring that service access is allowed for both the burners and blower.
- These models **ARE NOT** CSA listed or approved for installation into a **HUD Approved Modular Home** or a **Manufactured (Mobile) Home**.
- This furnace is not approved for installation in trailers or recreational vehicles.
- **Failure to carefully read and follow all instructions in this manual can result in furnace malfunction, death, personal injury and/or property damage.**
- Furnaces for installation on combustible flooring shall not be installed directly on carpeting, tile or other combustible material other than wood flooring.

- Check the rating plate and power supply to be sure that the electrical characteristics match. All models use nominal 115 VAC, 1 Phase, 60-Hertz power supply. **DO NOT CONNECT THIS APPLIANCE TO A 50 HZ POWER SUPPLY OR A VOLTAGE ABOVE 130 VOLTS.**
- Furnace shall be installed so the electrical components are protected from water.
- Installing and servicing heating equipment can be hazardous due to the electrical components and the gas fired components. Only trained and qualified personnel should install, repair, or service gas heating equipment. Untrained service personnel can perform basic maintenance functions such as cleaning and replacing the air filters. When working on heating equipment, observe precautions in the manuals and on the labels attached to the unit and other safety precautions that may apply.
- These instructions cover minimum requirements and conform to existing national standards and safety codes. In some instances these instructions exceed certain local codes and ordinances, especially those who have not kept up with changing residential and non-HUD modular home construction practices. These instructions are required as a minimum for a safe installation.

## COMBUSTION AIR QUALITY (LIST OF CONTAMINANTS)

The furnace will require **OUTDOOR AIR** for combustion when the furnace is located in any of the following environments.

- Restricted Environments
- Commercial buildings
- Buildings with indoor pools
- Furnaces installed in laundry rooms
- Furnaces installed in hobby or craft rooms
- Furnaces installed near chemical storage areas
- Chemical Exposure

The furnace will require **OUTDOOR AIR** for combustion when the furnace is located in an area where the furnace is being exposed to the following substances and / or chemicals.

- Permanent wave solutions
- Chlorinated waxes and cleaners
- Chlorine based swimming pool chemicals
- Water softening chemicals
- De-icing salts or chemicals
- Carbon tetrachloride
- Halogen type refrigerants
- Cleaning solvents (such as perchloroethylene)
- Printing inks, paint removers, varnishes, etc.
- Hydrochloric acid
- Cements and glues
- Antistatic fabric softeners for clothes dryers
- Masonry acid washing materials

When outdoor air is used for combustion, the combustion air intake pipe termination must be located external to the building and in an area where there will be no exposure to the substances listed above.

### **WARNING**

*The furnace area must not be used as a broom closet or for any other storage purposes, as a fire hazard may be created. Never store items such as the following on, near or in contact with the furnace.*

1. Spray or aerosol cans, rags, brooms, dust mops, vacuum cleaners or other cleaning tools.
2. Soap powders, bleaches, waxes or other cleaning compounds; plastic items or containers; gasoline, kerosene, cigarette lighter fluid, dry cleaning fluids or other volatile fluid.
3. Paint thinners and other painting compounds.
4. Paper bags, boxes or other paper products

***Never operate the furnace with the blower door removed. To do so could result in serious personal injury and/or equipment damage.***

**INSPECTION**

As soon as a unit is received, it should be inspected for possible damage during transit. If damage is evident, the extent of the damage should be noted on the carrier's freight bill. A separate request for inspection by the carrier's agent should be made in writing. Also, before installation the unit should be checked for screws or bolts, which may have loosened in transit. There are no shipping or spacer brackets which need to be removed.

**FURNACE LOCATION AND CLEARANCES**

The furnace shall be located using the following guidelines:

1. Where a minimum amount of air intake/vent piping and elbows will be required.
2. As centralized with the air distribution as possible.
3. Where adequate combustion air will be available (particularly when the appliance is not using outdoor combustion air).
4. Where it will not interfere with proper air circulation in the confined space.
5. Where the outdoor combustion air/vent terminal will not be blocked or restricted. Refer to "COMBUSTION AIR / VENT CLEARANCES" located in SECTION VII of these instructions. These minimum clearances must be maintained in the installation.
6. Where the unit will be installed in a level position with no more than 1/4" (6.4 mm) slope side-to-side and front-to-back to provide proper condensate drainage.

Installation in freezing temperatures:

1. Furnace shall be installed in an area where ventilation facilities provide for safe limits of ambient temperature under normal operating conditions. Ambient temperatures must not fall below 32°F (0°C) unless the condensate system is protected from freezing.
2. Do not allow return air temperature to be below 55° F (13° C) for extended periods. To do so may cause condensation to occur in the main heat exchanger, leading to premature heat exchanger failure.

**TABLE 1:** Unit Clearances to Combustibles

Application	Top	Front	Rear	Left Side	Right Side	Flue	Floor/ Bottom	Closet Alcove	Attic
	In.	In.	In.	In.	In.	In.			
Upflow	1 (25.4)	3	0 (0)	0 (0)	0 (0)	0 (0)	Combustible	Yes	Yes

**SECTION II: DUCTWORK**

**DUCTWORK GENERAL INFORMATION**

**The duct system's design and installation must:**

1. Handle an air volume appropriate for the served space and within the operating parameters of the furnace specifications.
2. Be installed in accordance with standards of NFPA (National Fire Protection Association) as outlined in NFPA pamphlets 90A and 90B (latest editions) or applicable national, provincial, or state, and local fire and safety codes.
3. Create a closed duct system. For residential and Non-HUD Modular Home installations, when a furnace is installed so that the supply ducts carry air circulated by the furnace to areas outside the space containing the furnace, the return air shall also be handled by a duct(s) sealed to the furnace casing and terminating outside the space containing the furnace.
4. Complete a path for heated or cooled air to circulate through the air conditioning and heating equipment and to and from the conditioned space.

**CAUTION**

*The cooling coil must be installed in the supply air duct, downstream of the furnace. Cooled air may not be passed over the heat exchanger.*

**WARNING**

*Improper installation in an ambient below 32°F (0.0° C) could create a hazard, resulting in damage, injury or death.*

3. If this furnace is installed in any area where the ambient temperature may drop below 32° F (0° C), a UL listed self-regulated heat tape must be installed on any condensate drain lines. It is required that self regulating heat tape rated at 3 watts per foot be used. This must be installed around the condensate drain lines in the unconditioned space. Always install the heat tape per the manufacturer's instructions. Cover the self-regulating heat tape with fiberglass, Armaflex or other heat resistant insulating material.
4. If this unit is installed in an unconditioned space and an extended power failure occurs, there will be potential damage to the condensate trap, drain lines and internal unit components. Following a power failure situation, do not operate the unit until inspection and repairs are performed.

**Clearances for access:**

Ample clearances should be provided to permit easy access to the unit. The following minimum clearances are recommended:

1. Twenty-four (24) inches (61 cm) between the front of the furnace and an adjacent wall or another appliance, when access is required for servicing and cleaning.
2. Eighteen (18) inches (46 cm) at the side where access is required for passage to the front when servicing or for inspection or replacement of flue/vent connections.

In all cases, accessibility clearances shall take precedence over clearances for combustible materials where accessibility clearances are greater.

**Installation in a residential garage:**

A gas-fired furnace for installation in a residential garage must be installed so the burner(s) and the ignition source are located not less than 18 inches (46 cm) above the floor, and the furnace must be located or protected to avoid physical damage by vehicles.

When the furnace is used in conjunction with a cooling coil, the coil must be installed parallel with, or in the supply air side of the furnace to avoid condensation in the primary heat exchanger. When a parallel flow arrangement is used, dampers or other means used to control airflow must be adequate to prevent chilled air from entering the furnace. If manually operated, the damper must be equipped with means to prevent the furnace or the air conditioner from operating unless the damper is in full heat or cool position.

**WARNING**

*The duct system must be properly sized to obtain the correct airflow for the furnace size that is being installed.*

*Refer to Table 7 and the furnace rating plate for the correct rise range and static pressures*

*If the ducts are undersized, the result will be high duct static pressures and/or high temperature rises which can result in a heat exchanger OVERHEATING CONDITION. This condition can result in premature heat exchanger failure, which can result in personal injury, property damage, or death.*

## DUCTWORK INSTALLATION AND SUPPLY PLENUM CONNECTION



A proper Heat Loss/Gain Calculation should be done on all installations for proper application of equipment. From this the ductwork sizing can be calculated, ACCA Manual J and D and industry standards are helpful.

Attach the supply plenum to the furnace or coil outlet duct connection flanges. This is typically through the use of S cleat material when a metal plenum is used. The use of an approved flexible duct connector is recommended on all installations to prevent noise transmission. All connections should be sealed to prevent air leakage. Sheet metal should be crosshatched to eliminate any popping when the indoor fan is energized.

When replacing an existing furnace, if the existing supply plenum is not the same size as the new furnace then the existing plenum must be removed and a new plenum installed that is of the proper size for the new furnace. The minimum plenum height is 12" (30 cm). If the plenum is shorter than 12" (30 cm) the turbulent air flow may cause the limit controls not to operate as designed if at all.

**NOTE:** When attaching duct flange, do not shoot the screw down into the casing. Use the formed flange intended for duct flange attachment.

The duct system is a very important part of the installation. **If the duct system is improperly sized the furnace will not operate properly.** The ducts attached to the furnace plenum should be of sufficient size so that the furnace operates at the specified external static pressure and within the air temperature rise specified on the nameplate.

**TABLE 2:** Minimum Duct Sizing For Proper Airflow

Input	Airflow	Return <sup>1</sup>	Rectangular <sup>2</sup>	Round <sup>2</sup>	Supply <sup>3</sup>	Rectangular <sup>2</sup>	Round <sup>2</sup>
BTU/H (kW)	CFM (m <sup>3</sup> )	In <sup>2</sup> (cm <sup>2</sup> )	in. x in. (cm x cm)	in. (cm) dia.	In <sup>2</sup> (cm <sup>2</sup> )	in. x in. (cm x cm)	in. (cm) dia.
40,000(17.6)	1,200 (34.0)	280 (711)	14 x 20 (35.6 x 50.8)	18 (45.7)	216 (549)	12 x 18 (30.5 x 45.7)	16 (40.6)
60,000 (17.6)	1,200 (34.0)	280 (711)	14 x 20 (35.6 x 50.8)	18 (45.7)	216 (549)	12 x 18 (30.5 x 45.7)	16 (40.6)
80,000 (23.4)	1,200 (34.0)	280 (711)	14 x 20 (35.6 x 50.8)	18 (45.7)	216 (549)	12 x 18 (30.5 x 45.7)	16 (40.6)
80,000 (23.4)	1,600 (45.3)	360 (914)	18 x 20 (45.7 x 50.8)	22 (55.8)	280 (711)	14 x 20 (35.6 x 50.8)	18 (45.7)
100,000 (29.3)	1,600 (45.3)	360 (914)	18 x 20 (45.7 x 50.8)	22 (55.8)	280 (711)	14 x 20 (35.6 x 50.8)	18 (45.7)
100,000 (29.3)	2,000 (56.6)	440 (1,118)	20 x 22 (50.8 x 55.8)	24 (60.9)	390 (991)	16 x 22 (40.6 x 55.8)	22 (55.8)
120,000 (35.2)	2,000 (56.6)	440 (1,118)	20 x 22 (50.8 x 55.8)	24 (60.9)	390 (991)	16 x 22 (40.6 x 55.8)	22 (55.8)

**NOTE:** This chart does not replace proper duct sizing calculations or take into account static pressure drop for run length and fittings. Watch out for the temperature rise and static pressures.

1. Maximum return air velocity in rigid duct @ 700 feet per minute (19.82 m<sup>3</sup> / minute).
2. Example return main trunk duct minimum dimensions.
3. Maximum supply air velocity in rigid duct @ 900 feet per minute (25.49 m<sup>3</sup> / minute).

**TABLE 3:** Round Duct Size

Round Duct Size	Calculated Area For Each Round Duct Size
inches (cm)	Sq.in (cm <sup>2</sup> )
5 (13)	19.6 (126)
6 (15)	28.2 (182)
7 (18)	38.4 (248)
8 (20)	50.2 (324)
9 (23)	63.6 (410)
10 (25)	78.5 (506)
11 (28)	95 (613)
12 (30)	113.1 (730)
13 (33)	132.7 (856)
14 (36)	153.9 (993)

1. The Air Temperature Rise is determined by subtracting the Return Air Temperature Reading from the Supply Air Temperature Reading.
2. The External Static Pressure is determined by adding the Supply Duct Static Pressure reading to the Return Duct Static Pressure reading and adding the pressure drop across any applied coil.

Table 2 is a guide for determining whether the rectangular duct system that the furnace is being connected to be of sufficient size for proper furnace operation.

Use the Example below to help you in calculating the duct area to determine whether the ducts have sufficient area so that the furnace operates at the specified external static pressure and within the air temperature rise specified on the nameplate.

The following are general duct sizing guidelines that may not serve to requirements of every application.

Example: The furnace input is 80,000 BTUH, 1,200 CFM blower requirement. The recommended duct area is 216 sq.in, there are two 8 x 12 rectangular ducts attached to the plenum and there are two 7 inch round ducts attached to the furnace.

1. Take 8 x 12, which equals 96 square inch x 2 = 192 square inches then go to round duct size located in Table 3.
2. The square inch area for 7 inch round ducts, 38.4 square inch x 2 = 76.8 square inches,
3. Then take the 192 square inch from the rectangular duct and add it to the 76.8 square inch of round duct. The total square inch of duct attached to the furnace supply plenum is 268.8 square inches. This exceeds the recommended 216 square inch of duct.

In this example, the duct system attached to the plenum has a sufficient area so that the furnace operates at the specified external static pressure and within the air temperature rise specified on the nameplate. Providing the return duct is properly sized as well.

TABLES 2 AND 3 are to be used as a guide only to help the installer determine if the duct sizes are large enough to obtain the proper air flow (CFM) through the furnace. TABLES 2 and 3 ARE NOT to be used to design ductwork for the building where the furnace is being installed. There are several variables associated with proper duct sizing that are not included in the tables. To properly design the ductwork for the building, Refer to the ASHRAE Fundamentals Handbook, Chapter on "DUCT DESIGN" or a company that specializes in Residential and Modular Home duct designs.

**IMPORTANT:** The minimum plenum height is 12" (30 cm). The furnace will not operate properly on a shorter plenum height. The minimum recommended rectangular duct height is 4" (10 cm) attached to the plenum.

**IMPORTANT:** The air temperature rise should be taken only after the furnace has been operating for at least 15 minutes. Temperatures and external static pressures should be taken 6" (15 cm) past the first bend from the furnace in the supply duct and the return duct. If an external filter box or an electronic air cleaner is installed, take the return air readings before the filter box or air cleaner.

**WARNING**

The supply air temperature **MUST NEVER** exceed the **Maximum Supply Air Temperature**, specified on the nameplate. Operating the furnace above the maximum supply air temperature will cause the heat exchanger to overheat, causing premature heat exchanger failure. Improper duct sizing, dirty air filters, incorrect manifold pressure, incorrect gas orifice and/or a faulty limit switch can cause the furnace to operate above the maximum supply air temperature. Refer to sections II and III for additional information on correcting the problem.

If a matching cooling coil is used, it may be placed directly on the furnace outlet and sealed to prevent leakage. Follow the coil instructions for installing the supply plenum. On all installations without a coil, a removable access panel is recommended in the outlet duct such that smoke or reflected light would be observable inside the casing to indicate the presence of leaks in the heat exchanger. This access cover shall be attached in such a manner as to prevent leaks.

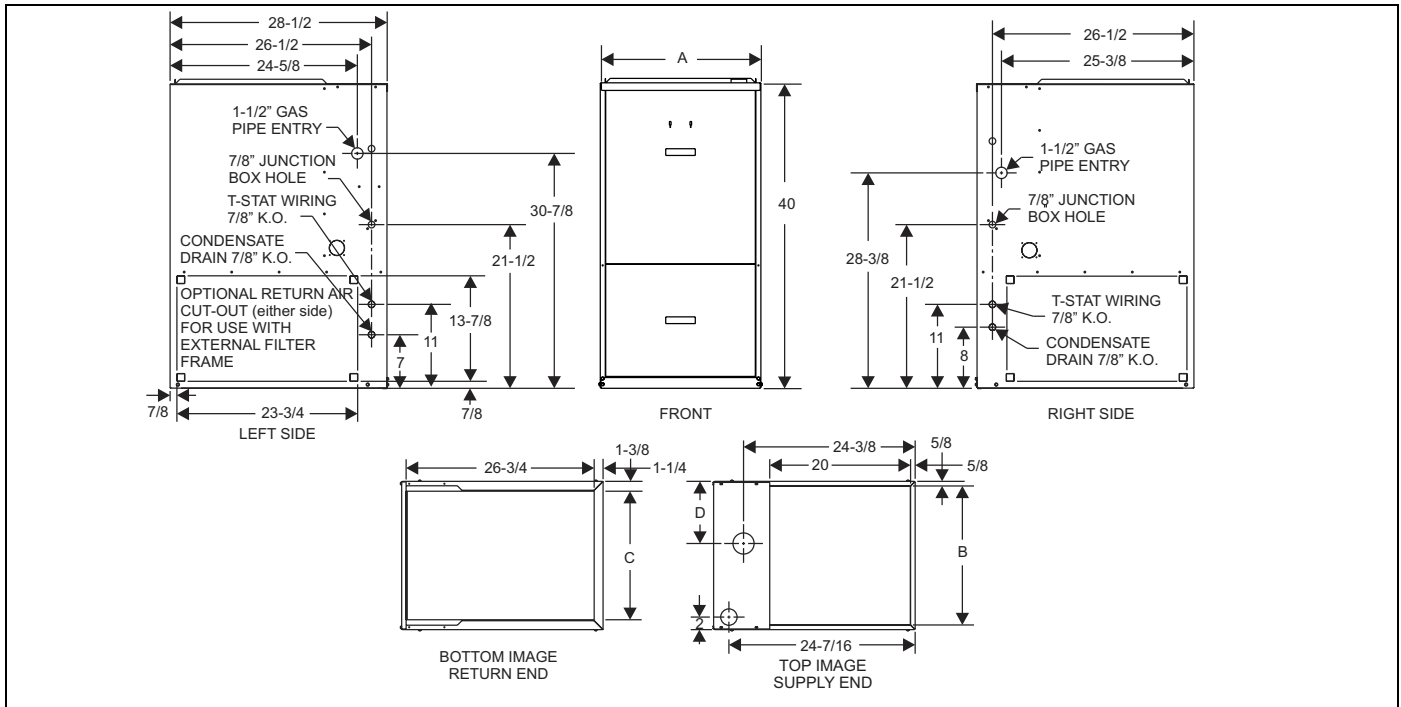

FIGURE 1: Dimensions

BTUH (kW) Input/Output	CFM m <sup>3</sup> /min	Cabinet Size	Cabinet Dimension							
			A (in.)	A (cm)	B (in.)	B (cm)	C (in.)	C (cm)	D (in.)	D (cm)
40/38 (11.7/10.8)	1200 (33.98)	A	14-1/2	36.8	13-1/4	33.7	12-1/8	30.8	6-1/4	15.9
60/56 (17.8/16.1)	1200 (33.98)	B	17-1/2	44.4	16-1/4	41.3	15-1/8	38.4	8-1/2	21.6
80/75 (23.4/22.0)	1200 (33.98)	B	17-1/2	44.4	16-1/4	41.3	15-1/8	38.4	8-1/2	21.6
80/75 (23.4/22.0)	1600 (45.31)	C	21	53.3	19-3/4	50.2	18-1/2	47.0	8-7/8	22.5
100/93 (29.3/27.8)	1600 (45.31)	C	21	53.3	19-3/4	50.2	18-1/2	47.0	8-7/8	22.5
100/93 (29.3/27.8)	2000 (56.63)	C	21	53.3	19-3/4	50.2	18-1/2	47.0	8-7/8	22.5
120/112 (35.1/32.8)	2000 (56.63)	D	24-1/2	62.2	23-1/4	59.4	21-7/8	55.6	10-5/8	27.0

**RESIDENTIAL AND NON HUD MODULAR HOME RETURN PLENUM CONNECTION**

Return air may enter the furnace through the side(s) or bottom depending on the type of application. Return air may not be connected into the rear panel of the unit. In order to stay within the velocity rating of the filter(s), it is recommended that applications over 1800 CFM (57 m<sup>3</sup>/min) use return air from two sides, one side and the bottom or bottom only. For single return application, see data and notes on blower performance data tables in this manual.

**BOTTOM RETURN AND ATTIC INSTALLATIONS**

Bottom return applications normally pull return air through a base platform or return air plenum. Be sure the return platform structure or return air plenum is suitable to support the weight of the furnace.

The furnace base is equipped with a rectangular blockoff panel that can be removed by performing the following steps:

1. Lay the furnace on its back.
2. Remove the toe plate. See Figure 2.
3. Slide the blockoff panel out and then replace the toe plate.
4. Bend the 3/4" flanges that will be used to attach the return air plenum using the scribe marks in the furnace base. Refer to Figure 1 "Bottom Image Return End".
5. Be sure to seal the furnace to plenum connections to prevent air leakage. Refer to Figure 1 for unit and plenum dimensions.

Attic installations must meet all minimum clearances to combustibles and have floor support with required service accessibility.

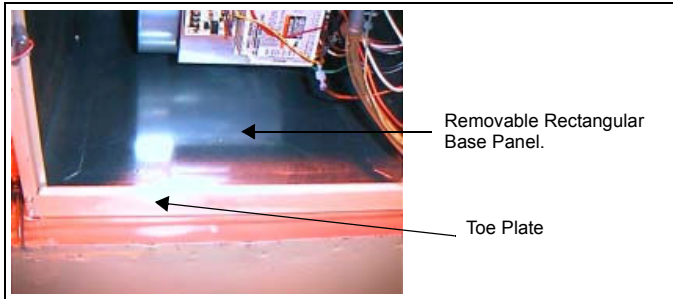

FIGURE 2: Furnace Base Rectangular Blockoff Panel

**IMPORTANT:** If an external mounted filter rack is being used see the instructions provided with that accessory for proper hole cut size.

### SECTION III: FILTERS

#### FILTER INSTALLATION

All applications require the use of a filter.

Filters must be installed external to the furnace cabinet. **DO NOT attempt to install filters inside the furnace.**

TABLE 4: Recommended Filter Sizes

Input / Output BTU/H (kW)	CFM (m <sup>3</sup> /min)	Cabinet Size	Side Return Filter in. (cm)	Bottom Return Filter in. (cm)
40/38 (11.7/10.8)	1200 (34.0)	A	16 x 25 (41 x 64)	14 x 25 (36 x 64)
60/56 (17.8/16.1)	1200 (34.0)	B	16 x 25 (41 x 64)	16 x 25 (41 x 64)
80/75 (23.4/22.0)	1200 (34.0)	B	16 x 25 (41 x 64)	16 x 25 (41 x 64)
80/75 (23.4/22.0)	1600 (45.3)	C	16 x 25 (41 x 64)	20 x 25 (51 x 64)
100/93 (29.3/27.8)	1600 (45.3)	C	16 x 25 (41 x 64)	20 x 25 (51 x 64)
100/93 (29.3/27.8)	2000 (56.6)	C	16 x 25 (41 x 64)	20 x 25 (51 x 64)
120/112 (35.1/32.8)	2000 (56.6)	D	(2) 16 x 25 (2) (41 x 64)	22 x 25 (56 x 64)

#### SIDE RETURN - FILTER INSTALLATION

Locate and mark the side return opening. Refer to Figure 1 for dimensions of the cutout.

Install the side filter rack following the instructions provided with that accessory. If a filter(s) is provided at another location in the return air system, the ductwork may be directly attached to the furnace side panel. If not provided with the furnace, an accessory filter rack is available for mounting the filter external to the cabinet.

**IMPORTANT:** Some accessories such as electronic air cleaners and pleated media may require a larger side opening. Follow the instructions supplied with that accessory for side opening requirements. Do not cut the opening larger than the dimensions shown in Figure 1.

## ⚠ CAUTION

All installations must have a filter installed.

### SECTION IV: GAS PIPING

#### GAS SAFETY

## ⚠ DANGER

An overpressure protection device, such as a pressure regulator, must be installed in the gas piping system upstream of the furnace and must act to limit the downstream pressure to the gas valve so it does not exceed 0.5 PSI {14" w.c. (3.48 kPa)}. Pressures exceeding 0.5 PSI {14" w.c. (3.48 kPa)} at the gas valve will cause damage to the gas valve, resulting in a fire or explosion or cause damage to the furnace or some of its components that will result in property damage and loss of life.

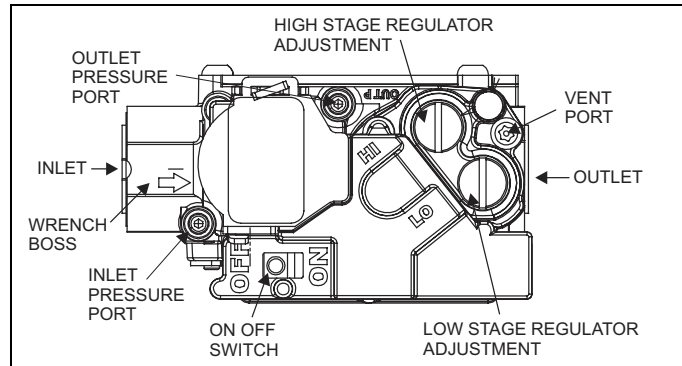

FIGURE 3: Gas Valve

**IMPORTANT:** Plan your gas supply before determining the correct gas pipe entry. Use 90-degree service elbow(s), or short nipples and conventional 90-degree elbow(s) to enter through the cabinet access holes.

#### GAS PIPING INSTALLATION

Properly sized wrought iron, approved flexible or steel pipe must be used when making gas connections to the unit. If local codes allow the use of a flexible gas appliance connection, always use a new listed connector. Do not use a connector that has previously serviced another gas appliance.

Some utility companies or local codes require pipe sizes larger than the minimum sizes listed in these instructions and in the codes. The furnace rating plate and the instructions in this section specify the type of gas approved for this furnace - only use those approved gases. The installation of a drip leg and ground union is required. Refer to Figure 4.

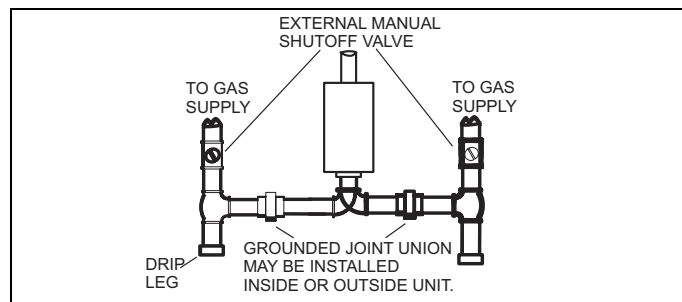

FIGURE 4: Gas Piping

The furnace must be isolated from the gas supply piping system by closing its individual external manual shutoff valve during any pressure testing of the gas supply piping system at pressures equal to or greater than 1/2 psig (3.5 kPa).

### CAUTION

*The gas valve body is a very thin casting that cannot take any external pressure. Never apply a pipe wrench to the body of the gas valve when installing piping. A wrench must be placed on the octagonal hub located on the gas inlet side of the valve. Placing a wrench to the body of the gas valve will damage the valve causing improper operation and/or the valve to leak.*

Gas piping may be connected from either side of the furnace using any of the gas pipe entry knockouts on both sides of the furnace. Refer to Figure 1 dimensions.

The inlet to the gas valve lines up directly with the opening in the left side of the furnace casing. To line up with the opening in the right side of the casing, two street ells should be used.

**TABLE 5:** Nominal Manifold Pressure - High Fire

Second Stage Manifold Pressures (in wc)				
		Altitude (feet)		
		0-7999	8000-8999	9000-9999
Gas Heating Value (BTU/cu ft.)	800	3.5	3.5	3.5
	850	3.5	3.5	3.5
	900	3.5	3.5	3.5
	950	3.5	3.5	3.3
	1000	3.5	3.2	2.9
	1050	3.5	2.9	2.7
	1100	3.2	2.7	2.4
	2500 (LP)	9.8	8.2	7.5

### **GAS ORIFICE CONVERSION FOR PROPANE (LP)**

This furnace is constructed at the factory for natural gas-fired operation, but may be converted to operate on propane (LP) gas by using a factory-supplied LP conversion kit. Follow the instructions supplied with the LP kit. Refer to the instructions in the propane (LP) conversion kit for the proper gas orifice size.

### **HIGH ALTITUDE GAS ORIFICE CONVERSION**

This furnace is constructed at the factory for natural gas-fired operation at 0 – 8,000 feet (0-m – 2,438 m) above sea level.

The manifold pressure must be changed in order to maintain proper and safe operation when the furnace is installed in a location where the altitude is greater than 8,000 feet (2,438 m) above sea level. Refer to Tables 5 & 6 for proper manifold pressure settings.

### **HIGH ALTITUDE PRESSURE SWITCH CONVERSION**

For installation where the altitude is less than 8,000 feet (2,438 m), it is not required that the pressure switch be changed. For altitudes above 8,000 feet (2,438 m), see Table 17 Field Installed Accessories - High Altitude pressure Switch

Second Stage Manifold Pressures (kpa)				
		Altitude (m)		
		0-2437	2438-2742	2743-3048
Gas Heating Value (MJ/cu m)	29.8	0.87	0.87	0.87
	31.7	0.87	0.87	0.87
	33.5	0.87	0.87	0.87
	35.4	0.87	0.87	0.81
	37.3	0.87	0.80	0.73
	39.1	0.87	0.73	0.67
	41.0	0.80	0.66	0.61
	93.2 (LP)	2.44	2.03	1.86

**TABLE 6:** Nominal Manifold Pressure - Low Fire

First Stage Manifold Pressures (in wc)				
		Altitude (feet)		
		0-7999	8000-8999	9000-9999
Gas Heating Value (BTU/cu ft.)	800	1.7	1.7	1.7
	850	1.7	1.7	1.7
	900	1.7	1.7	1.7
	950	1.7	1.7	1.5
	1000	1.6	1.5	1.4
	1050	1.5	1.4	1.3
	1100	1.3	1.2	1.1
	2500 (LP)	4.1	3.8	3.5

First Stage Manifold Pressures (kpa)				
		Altitude (m)		
		0-2437	2438-2742	2743-3048
Gas Heating Value (MJ/cu m)	29.8	0.42	0.42	0.42
	31.7	0.42	0.42	0.42
	33.5	0.42	0.42	0.42
	35.4	0.42	0.42	0.38
	37.3	0.41	0.37	0.34
	39.1	0.37	0.34	0.31
	41.0	0.34	0.31	0.28
	93.2 (LP)	1.03	0.95	0.87

**▲ DANGER****PROPANE AND HIGH ALTITUDE CONVERSION KITS**

It is very important to choose the correct kit and/or gas orifices for the altitude and the type of gas for which the furnace is being installed.

Only use natural gas in furnaces designed for natural gas. Only use propane (LP) gas for furnaces that have been properly converted to use propane (LP) gas. Do not use this furnace with butane gas.

Incorrect gas orifices or a furnace that has been improperly converted will create an extremely dangerous condition resulting in premature heat exchanger failure, excessive sooting, high levels of carbon monoxide, personal injury, property damage, a fire hazard and/or death.

High altitude and propane (LP) conversions are required in order for the appliance to satisfactorily meet the application.

An authorized distributor or dealer must make all gas conversions.

In Canada, a certified conversion station or other qualified agency, using factory specified and/or approved parts, must perform the conversion.

The installer must take every precaution to insure that the furnace has been converted to the proper gas orifice size when the furnace is installed. Do not attempt to drill out any orifices to obtain the proper orifice size. Drilling out a gas orifice will cause misalignment of the burner flames, causing premature heat exchanger burnout, high levels of carbon monoxide, excessive sooting, a fire hazard, personal injury, property damage and/or death.

**SECTION V: ELECTRICAL POWER****ELECTRICAL POWER CONNECTIONS**

Field wiring to the unit must be grounded. Electric wires that are field installed shall conform to the temperature limitation for 63°F (35°C) rise wire when installed in accordance with instructions. Refer to Table 7 in these instructions for specific furnace electrical data.

**▲ CAUTION**

Use copper conductors only.

**TABLE 7:** Electrical and Performance Data

Input High/Low		Output High/Low		Nominal Airflow		Cabinet Width		Total Unit	AFUE	Air Temp. Rise	
MBH	kW	MBH	kW	CFM	m <sup>3</sup> /min	In.	cm	Amps	%	°F	°C
40/26	12/8	38/24	11/7	1200	34.0	14-1/2	36.8	9	94.0	35 - 65	19 - 36
60/39	18/11	56/36	16/11	1200	34.0	17-1/2	44.4	9	93.2	40 - 70	22 - 39
80/52	23/15	75/49	22/14	1200	34.0	17-1/2	44.4	9	92.5	45 - 75	25 - 42
80/52	23/15	75/49	22/14	1600	45.3	21	53.3	12	92.8	45 - 75	25 - 42
100/65	29/19	93/60	27/18	1600	45.3	21	53.3	12	92.5	45 - 75	25 - 42
100/65	29/19	93/60	27/18	2000	56.6	21	53.3	14	92.8	45 - 75	25 - 42
120/78	35/23	112/73	33/21	2000	56.6	24-1/2	62.2	14	93.2	40 - 70	22 - 39

Input High/Low		Max. Outlet Air Temp.		Blower		Blower Size		Max. Over-current Protect	Min. Wire Size (awg) @ 75 ft. One Way	Operating Wgt	Operating Wgt
MBH	kW	°F	°C	HP	Amps	In.	cm			Lbs.	Kg
40/26	12/8	165	73.9	1/2	7.7	11 x 8	27.9 x 20.3	20	14	119	54.1
60/39	18/11	170	76.7	1/2	7.7	11 x 8	27.9 x 20.3	20	14	133	60.5
80/52	23/15	175	79.4	1/2	7.7	11 x 8	27.9 x 20.3	20	14	140	63.6
80/52	23/15	175	79.4	3/4	10.2	11 x 10	27.9 x 25.4	20	14	155	70.5
100/65	29/19	175	79.4	3/4	10.2	11 x 10	27.9 x 25.4	20	14	160	72.7
100/65	29/19	175	79.4	1	12.8	11 x 11	27.9 x 27.9	20	12	162	73.6
120/78	35/23	170	76.7	1	12.8	11 x 11	27.9 x 27.9	20	12	178	80.9

Annual Fuel Utilization Efficiency (AFUE) numbers are determined in accordance with DOE Test procedures.

Wire size and over current protection must comply with the National Electrical Code (NFPA-70-latest edition) and all local codes.

The furnace shall be installed so that the electrical components are protected from water.



## SUPPLY VOLTAGE CONNECTIONS

**IMPORTANT:** The power connection leads and wiring box may be relocated to the left side of the furnace. Remove the screws and cut wire tie holding excess wiring. Reposition on the left side of the furnace and fasten using holes provided.

1. Provide a power supply separate from all other circuits. Install overcurrent protection and disconnect switch per local/national electrical codes. The switch should be close to the unit for convenience in servicing. With the disconnect or fused switch in the OFF position, check all wiring against the unit wiring label. Refer to the wiring diagram shown in Figure 24.
2. Remove the screws retaining the junction box cover. Route the power wiring through the opening in the unit into the junction box with a conduit connector or other proper connection. In the junction box there will be three wires, a Black Wire, a White Wire and a Green Wire. Connect the power supply as shown on the unit-wiring label on the inside of the blower compartment door or Figure 5. The black furnace lead must be connected to the L1 (hot) wire from the power supply. The white furnace lead must be connected to neutral. Connect the green furnace lead (equipment ground) to the power supply ground. An alternate wiring method is to use a field provided 2" (5.08 cm) x 4" (10.2 cm) box and cover on the outside of the furnace. Route the furnace leads into the box using a protective bushing where the wires pass through the furnace panel. After making the wiring connections replace the wiring box cover and screws.
3. The furnace's control system requires correct polarity of the power supply and a proper ground connection. If the power supply polarity is reversed, the control board will flash 9 times. The furnace will not operate until the polarity is corrected. Refer to "Furnace Diagnostics" section of the "User's Information, Maintenance, & Service Manual provided with this furnace.

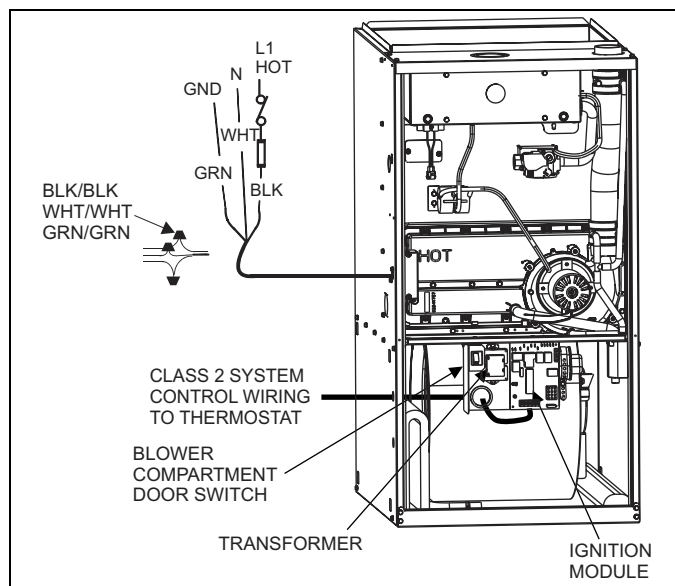

FIGURE 5: Electrical Wiring

## LOW VOLTAGE CONTROL WIRING CONNECTIONS

Install the field-supplied thermostat by following the instructions that come with the thermostat. With the thermostat set in the OFF position and the main electrical source disconnected, connect the thermostat wiring from the wiring connections on the thermostat to the terminal board on the ignition module, as shown in Figures 6 & 7. Electronic thermostats may require the common wire to be connected as shown in Figures 6 & 7. Apply strain relief to thermostat wires passing through cabinet. If air conditioning equipment is installed, use thermostat wiring to connect the Y and C terminals on the furnace control board to the proper wires on the condensing unit (unit outside).

**IMPORTANT:** Set the heat anticipator in the room thermostat to 0.45 amps. Setting it lower will cause short cycles. Setting it higher will cause the room temperature to exceed the set points.

**IMPORTANT:** Some electronic thermostats do not have adjustable heat anticipators. They may have other type cycle rate adjustments. Follow the thermostat manufacturer's instructions.

The 24-volt, 40 VA transformer is sized for the furnace components only, and should not be connected to power auxiliary devices such as humidifiers, air cleaners, etc. The transformer may provide power for an air conditioning unit contactor.

**Using a Single-Stage Heat Thermostat with the Furnace** - This two-stage furnace may be used with a single-stage thermostat. Place the "W2 Delay" jumper in the 10 minute, 15 minute or 20 minute position. If the jumper is left on the "OFF" pins, the furnace will operate only in low fire.

For additional connection diagrams for all UPG equipment refer to "Low Voltage System Wiring" document available online at [www.upgnet.com](http://www.upgnet.com) in the Product Catalog Section.



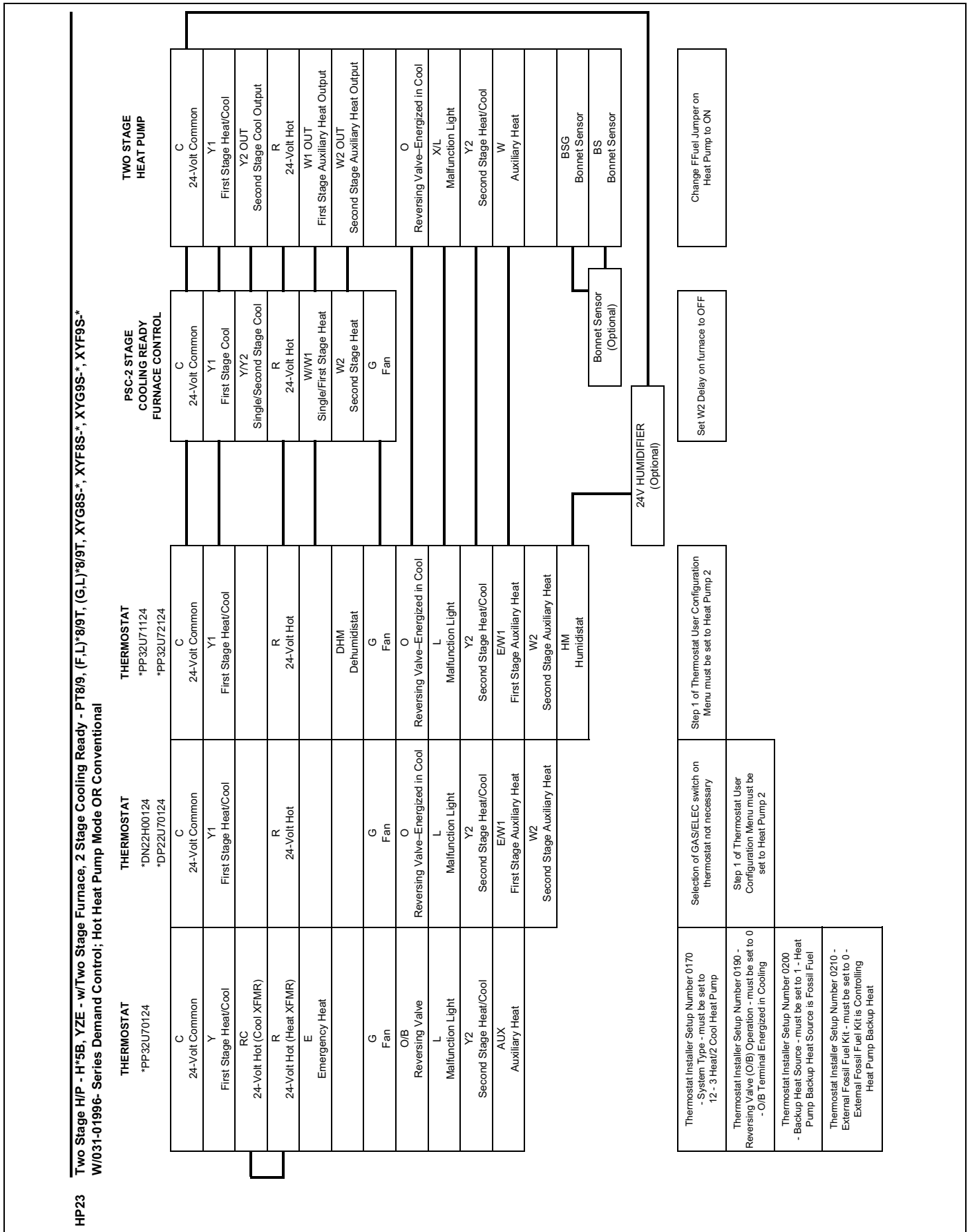

FIGURE 7: Thermostat Chart - HP

### ACCESSORY CONNECTIONS

The furnace control will allow power-switching control of various accessories. Refer to Figure 8, for connection details.

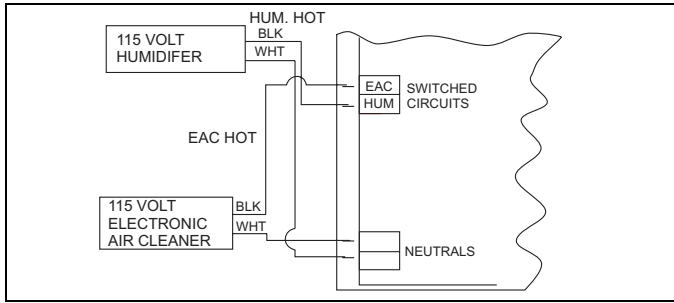

FIGURE 8: Accessory Connections

### ELECTRONIC AIR CLEANER CONNECTION

Two 1/4" (6.4 mm) spade terminals (EAC and NEUTRAL) for electronic air cleaner connections are located on the control board. The terminals provide 115 VAC (1.0 amp maximum) during circulating blower operation.

### HUMIDIFIER CONNECTION

Two 1/4" (6.4 mm) spade terminals (HUM and NEUTRAL) for humidifier connections are located on the control board. The terminals provide 115 VAC (1.0 amp maximum) during heating system operation.

### TWINNING

These furnaces are not to be twinned. If more than one furnace is needed in an application, each furnace must have its own complete duct system and its own wall thermostat.

## SECTION VI: COMBUSTION AIR AND VENT SYSTEM

### COMBUSTION AIR AND VENT SAFETY

This Category IV, dual certified direct vent furnace is designed for residential application. It may be installed without modification to the condensate system in a basement, garage, equipment room, alcove, attic or any other indoor location where all required clearance to combustibles and other restrictions are met. The combustion air and the venting system must be installed in accordance with Section 5.3, Air for Combustion and Ventilation, of the National Fuel Gas Code Z223.1/NFPA 54 (latest edition), or Sections 7.2, 7.3 or 7.4 of CSA B149.1, National Gas and Propane Codes (latest edition) or applicable provisions of the local building code and these instructions.

**IMPORTANT:** The "VENT SYSTEM" must be installed as specified in these instructions for Residential and Non HUD Modular Homes. The sealed combustion air / vent system is the only configuration that can be installed in a Non HUD Modular Home.

### WARNING

*This furnace may not be common vented with any other appliance, since it requires separate, properly sized air intake and vent lines. The furnace shall not be connected to any type of B, BW or L vent or vent connector, and not connected to any portion of a factory-built or masonry chimney*  
*The furnace shall not be connected to a chimney flue serving a separate appliance designed to burn solid fuel.*

### CAUTION

*When combustion air pipe is installed above a suspended ceiling or when it passes through a warm and humid space, the pipe must be insulated with 1/2" Armaflex or other heat resistant type insulation if two feet or more of pipe is exposed.*  
*Vent piping must be insulated if it will be subjected to freezing temperatures such as routing through unheated areas or through an unused chimney.*

### COMBUSTION AIR/VENT PIPE SIZING

Select the correct size from Table 9. The size will be determined by a combination of furnace model, total length of run, and the number of elbows required. The following rules must also be observed.

1. Long radius (sweep) elbows are required for all units.
2. Elbows are assumed to be 90 degrees. Two 45-degree elbows count as one 90-degree elbow.
3. Elbow count refers to combustion air piping and vent piping separately. For example, if the table allows for 5 elbows, this will allow a maximum of 5 elbows in the combustion air piping and a maximum of 5 elbows in the vent piping.
4. Three vent terminal elbows (two for vent pipe and one for air intake pipe) are already accounted for as vent termination.
5. Combustion air and vent piping must be of the same diameter.
6. All combustion air/vent pipe and fittings must conform to American National Standards Institute (ANSI) standards and American Society for Testing and Materials (ASTM) standards D1785 (Schedule 40 PVC), D2665 (PVC-DWV), F891 (PVC-DWV Cellular Core), D2241 (SDR-21 and SDR-26 PVC), D2261 (ABS-DWV), or F628 (Schedule 40 ABS). Pipe cement and primer must conform to ASTM Standards D2564 (PVC) or D2235 (ABS).
7. The use of flexible connectors or no hub connectors in the vent system is not allowed. This type connection is allowed in the combustion air pipe near the furnace for air conditioning coil accessibility.
8. Sidewall horizontal vent terminals and roof mounted vertical terminals may be field fabricated. Standard PVC/SRD fittings may be used. Terminal configuration must comply as detailed in this section.

**IMPORTANT:** Accessory concentric vent / intake termination kits 1CT0302 and 1CT0303 are available and approved for use with these furnaces. Horizontal sidewall vent terminations kit 1HT0901 is also approved for use with these furnaces.

**IMPORTANT:** Intake and vent pipe connections are sized as shown in Table 8. However, most models require larger vents and some installations will require larger intake piping. Use Table 9 for the sizes of the pipe that can be used with each model.

TABLE 8: Combustion Air Intake and Vent Connection Size at Furnace (All Models)

FURNACE VENT CONNECTION SIZES		
Furnace Input	60 - 100 MBH (17.6-29.3 kW)	120 MBH (35.2 kW)
Intake Pipe Size	2" (51 mm)	3" (76 mm)
Vent Pipe Size	2" (51 mm)	2" (51 mm)

**TABLE 9:** Combustion Air Supply and Vent Piping

MAXIMUM ELBOWS AND VENT LENGTHS										
Models Input BTUH (kW)	Pipe Size Inches (cm)	Maximum Number of Elbows*								Minimum Length
		1	2	3	4	5	6	7	8	
40,000 (11.7)	1-1/2 (3.8)	30	25	20	10	N/A	N/A	N/A	N/A	5
40,000 (11.7)	2 (5.1)	70	65	60	55	50	45	35	25	5
60,000 (17.6)	1-1/2 (3.8)	30	25	20	10	N/A	N/A	N/A	N/A	5
60,000 (17.6)	2 (5.1)	60	55	50	45	40	30	20	10	5
60,000 (17.6)	3 (7.6)	85	80	75	70	65	60	50	40	20
80,000 (23.4)	1-1/2 (3.8)	20	15	N/A	N/A	N/A	N/A	N/A	N/A	5
80,000 (23.4)	2 (5.1)	60	55	50	45	40	30	20	10	5
80,000 (23.4)	3 (7.6)	85	80	75	70	65	60	50	40	20
100,000 (29.3)	2 (5.1)	25	20	15	N/A	N/A	N/A	N/A	N/A	5
100,000 (29.3)	3 (7.6)	85	80	75	70	65	60	50	40	20
120,000 (35.1)	3 (7.6)	75	70	65	60	55	45	35	25	5

\* Three elbows (two in vent pipe and one in the air intake pipe) are already accounted for and need not be included in the elbow count from the Table above.

NOTE: If installing furnace at altitudes between 2000 - 4500 ft. (609.6 - 1371.6m), intake and vent pipe length must be reduced by 10 ft. (3.05 m). If the installation requires the maximum allowable intake and vent pipe length, the furnace must be converted for high altitude operation. Refer to the proper high altitude application instruction for details.

Example: An 80,000 BTUH (23.5 kW) unit requires 35 ft (10.7 m) of vent with five elbows. In the Table above, look at the three rows with 80,000 (23.5 kW) in the "Models" column. then look to the right in those rows to the five elbows column. It shows N/A in the 1-1/2" (3.8 cm) row, so 1-1/2" (5.1 cm) pipe cannot be used. the 2" (5.1 cm) pipe row shows 40 ft (12.2 m), so up to 40 ft (12.2 m) of 2" (5.1 cm) pipe can be used with five elbows. The 3" pipe row shows 65 ft (19.8 m), so up to 65 ft (19.8 m) of 3" (7.62 cm) pipe can be used. Therefore, in this example, either 2" (5.1 cm) or 3" (7.62 cm) pipe can be used.

### COMBUSTION AIR AND VENT PIPING ASSEMBLY

The final assembly procedure for the combustion air and vent piping is as follows:

- Cut piping to the proper length beginning at the furnace.
- Deburr the piping inside and outside.
- Chamfer (bevel) the outer edges of the piping.
- Dry-fit the vent piping assembly from the furnace to the outside termination checking for proper fit support and slope.
- Dry-fit the combustion air piping assembly checking for proper fit, support and slope on the following systems:
  - Sealed combustion air systems from the furnace to the outside termination.

- Ventilated combustion air systems from the furnace to the attic or crawl space termination.

### CAUTION

*Solvent cements are flammable and must be used in well-ventilated areas only. Keep them away from heat, sparks and open flames. Do not breathe vapors and avoid contact with skin and eyes.*

- Disassemble the combustion air and vent piping, apply cement primer and the cement per the manufactures instructions. Primer and cement must conform to ASTM D2564 for PVC, or ASTM D2235 for ABS piping.
- All joints must provide a permanent airtight and watertight seal.
- Support the combustion air and vent piping such that it is angled a minimum of 1/4" per foot (21 mm/m) so that condensate will flow back towards the furnace. Piping should be supported with pipe hangers to prevent sagging.
- Seal around the openings where the combustion air and / or vent piping pass through the roof or sidewalls.

### COMBUSTION AIR / VENT CLEARANCES

**IMPORTANT:** The vent must be installed with the following minimum clearances, and must comply with local codes and requirements.

**VENT CLEARANCES**

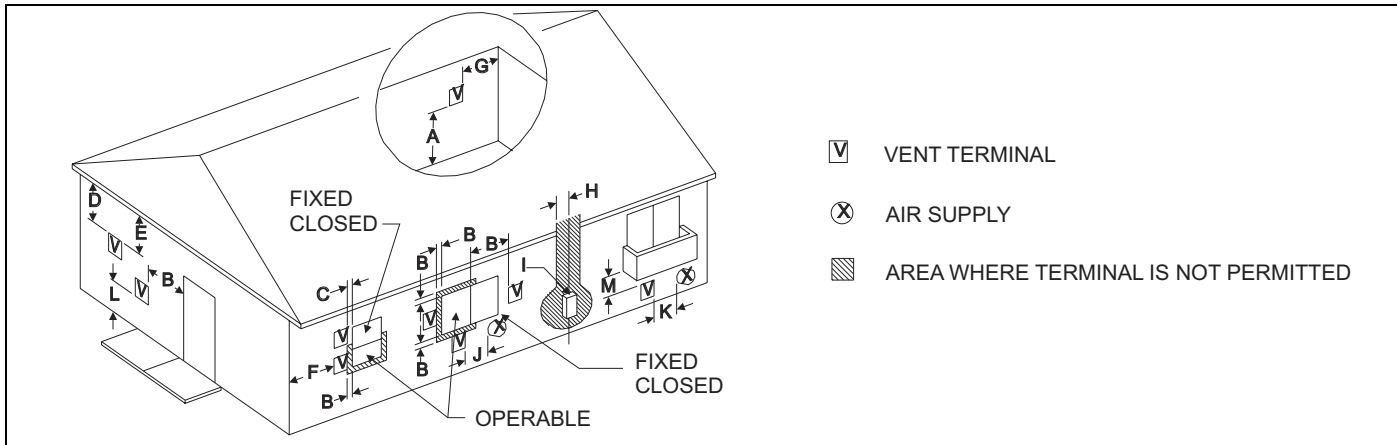

**FIGURE 9: Home Layout**

	Canadian Installations <sup>1</sup>	US Installation <sup>2</sup>
A. Clearance above grade, veranda, porch, deck, or balcony	12 inches (30 cm)	12 inches (30 cm)
B. Clearance to window or door that may be opened	12 inches (30 cm) for models <100,000 BTUH (30 kW), 36 inches (91 cm) for models >100,000 BTUH (30 kW)	Two-pipe (direct vent) applications: 9 inches (23 cm) for models <50,000 BTUH (15 kW), 12 inches (30 cm) for models >50,000 BTUH (15 kW). Single-pipe applications: 4 feet.
C. Clearance to permanently closed window	4 Feet	4 Feet
D. Vertical clearance to ventilated soffit located above the terminal within a horizontal distance of 2 feet (61 cm) from the center line of the terminal	4 Feet	4 Feet
E. Clearance to unventilated soffit	12 Inches	12 Inches
F. Clearance to outside corner	12 Inches	12 Inches
G. Clearance to inside corner	12 Inches (two-pipe), 6 Feet (one-pipe)	12 Inches (two-pipe), 6 Feet (one-pipe)
H. Clearance to each side of center line extended above meter/regulator assembly	3 feet (91 cm) within a height 15 feet (4.5 m) above the meter/regulator assembly	3 feet (91 cm) within a height 15 feet (4.5 m) above the meter/regulator assembly
I. Clearance to service regulator vent outlet	3 feet (91 cm)	3 feet (91 cm)
J. Clearance to nonmechanical air supply inlet to building or the combustion air inlet to any other appliance	12 inches (30 cm) for models <100,000 BTUH (30 kW), 36 inches (91 cm) for models >100,000 BTUH (30 kW)	Two-pipe (direct vent) applications: 9 inches (23 cm) for models <50,000 BTUH (15 kW), 12 inches (30 cm) for models >50,000 BTUH (15 kW). Single-pipe applications: 4 feet.
K. Clearance to a mechanical supply inlet	6 feet (1.83 m)	3 feet (91 cm) above if within 10 feet (3 m) horizontally
L. Clearance above paved sidewalk or paved driveway located on public property	7 feet (2.13 m) †	7 feet (2.13 m) †
M. Clearance under veranda, porch, deck, or balcony	12 inches (30 cm) ‡	12 inches (30 cm) ‡
Dryer Vent **	3 ft (91.44 cm)	3 ft (91.44 cm)
Plumbing Vent Stack **	3 ft (91.44 cm)	3 ft (91.44 cm)
Gas Appliance Vent Terminal **	3 ft (91.44 cm) *	3 ft (91.44 cm) *
Vent Termination from any Building Surface	12" (30.4 cm)	12" (30.4 cm)
Above anticipated snow depth	12" (30.4 cm)	12" (30.4 cm)
A. Clearance above grade, veranda, porch, deck, or balcony	12 inches (30 cm)	12 inches (30 cm)
B. Clearance to window or door that may be opened	12 inches (30 cm) for models <100,000 BTUH (30 kW), 36 inches (91 cm) for models >100,000 BTUH (30 kW)	Two-pipe (direct vent) applications: 9 inches (23 cm) for models <50,000 BTUH (15 kW), 12 inches (30 cm) for models >50,000 BTUH (15 kW). Single-pipe applications: 4 feet.
C. Clearance to permanently closed window	4 Feet	4 Feet
D. Vertical clearance to ventilated soffit located above the terminal within a horizontal distance of 2 feet (61 cm) from the center line of the terminal	4 Feet	4 Feet

1. In accordance with the current CSA B149.1-00, Natural Gas and Propane Installation Code.

2. In accordance with the current ANSI Z223.1 / NFPA 54, National Gas Code.

† A vent shall not terminate directly above a sidewalk or paved driveway that is located between two single family dwellings and serves both dwellings.

‡ Permitted only if veranda, porch, deck, or balcony is fully open on a minimum of two sides beneath the floor. For clearance not specified in ANSI Z223.1 / NFPA 54 or CSA B149.1-00.

Clearance in accordance with local installation codes and the requirements of the gas supplier and the manufacturer's Installation Manual.

Any fresh air or make up inlet for dryer or furnace area is considered to be forced air inlet.

Avoid areas where condensate drippage may cause problems such as above planters, patios, or adjacent to windows where steam may cause fogging.

A terminus of a vent shall be either:

Fitted with a cap in accordance with the vent manufacturer's installation instructions, or In accordance with the installation instructions for a special venting system.

\* Does not apply to multiple installations of this furnace model. Refer to "VENTING MULTIPLE UNITS" in this section of these instructions.

IMPORTANT: Consideration must be given for degradation of building materials by flue gases. Sidewall termination may require sealing or shielding of building surfaces with a corrosion resistant material to protect against combustion product corrosion. Consideration must be given to wind direction in order to prevent flue products and/or condensate from being blown against the building surfaces. If a metal shield is used it must be a stainless steel material at a minimum dimension of 20 inches. It is recommended that a retaining type collar be used that is attached to the building surface to prevent movement of the vent pipe.

Responsibility for the provision of proper adequate venting and air supply for application shall rest with the installer.

Vent shall extend high enough above building, or a neighboring obstruction, so that wind from any direction will not create a positive pressure in the vicinity of the vent.

## VENT SYSTEM

This furnace is certified to be installed with one of two possible vent configurations.

1. Horizontal vent system. This vent system can be installed completely horizontal or combinations of horizontal, vertical, or offset using elbows.
2. Vertical vent system. This vent system can be installed completely vertical or a combination of horizontal, vertical, or offset using elbows.

## HORIZONTAL VENT APPLICATIONS AND TERMINATION

When selecting the location for a horizontal combustion air / vent termination, the following should be considered:

1. Observe all clearances listed in vent clearances in these instructions.
2. Termination should be positioned where vent vapors will not damage plants or shrubs or air conditioning equipment.
3. Termination should be located where it will not be affected by wind gusts, light snow, airborne leaves or allow recirculation of flue gases.
4. Termination should be located where it will not be damaged or exposed to flying stones, balls, etc.
5. Termination should be positioned where vent vapors are not objectionable.
6. Horizontal portions of the vent system must slope upwards and be supported to prevent sagging.
7. Sealed combustion air systems must be installed so the vent and the combustion air pipes terminate in the same atmospheric zone. Refer to Figures 11 or 12.

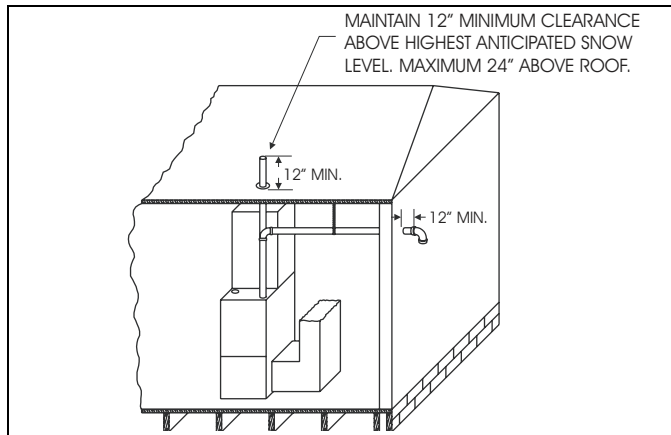

FIGURE 10: Termination Configuration - 1 Pipe

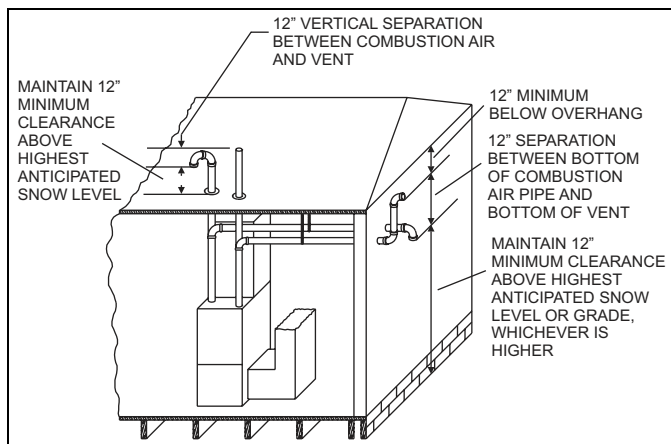

FIGURE 11: Termination Configuration - 2 Pipe

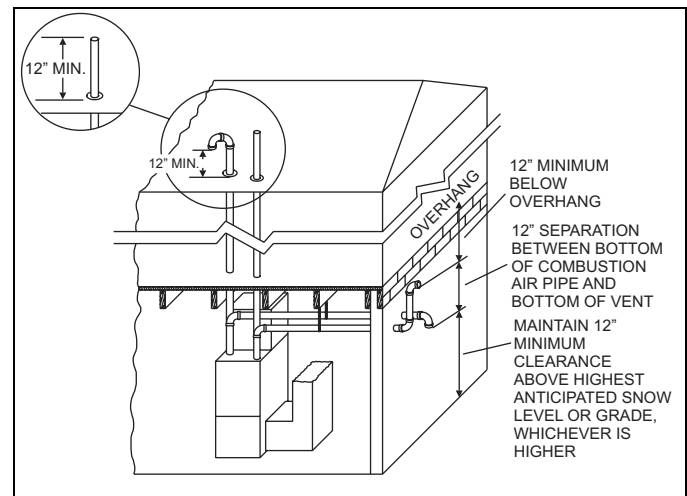

FIGURE 12: Termination Configuration - 2 Pipe Basement

## VERTICAL VENT APPLICATIONS AND TERMINATION

Roof mounted vertical terminals may be field fabricated. Standard PVC/SRD fittings may be used. If installing a vertical venting system through any unconditioned space such as an attic or crawl space it must be insulated.

1. Observe all clearances listed in vent clearances in these instructions.
2. Termination should be positioned where vent vapors are not objectionable.
3. Termination should be located where it will not be affected by wind gusts, light snow, or allow recirculation of flue gases.
4. Termination should be located where it cannot be damaged, plugged or restricted by tree limbs, leaves and branches.
5. Horizontal portions of the vent system must slope upwards and be supported to prevent sagging.
6. Sealed combustion air systems must be installed so the vent and the combustion air pipes terminate in the same atmospheric zone. Refer to Figures 11 or 12.

## VENTING MULTIPLE UNITS

Multiple units can be installed in a space or structure as either a single pipe configuration or a two-pipe configuration.

The combustion air side of the single pipe configuration shown in Figure 10 is referred to in these instructions as ambient combustion air supply. Follow the instructions for ambient combustion air installations, paying particular attention to the section on air source from inside the building. The vent for a single pipe system must be installed as specified in the venting section of these instructions with the vent terminating as shown in Figures 11 or 12. Each furnace must have a separate vent pipe. Under NO circumstances can the two vent pipe be tied together.

The combustion airside of the two-pipe configuration shown in Figures 11 or 12 can be installed so the combustion air pipe terminates as described in outdoor combustion air or ventilated combustion air sections in these instructions. Follow the instructions for outdoor combustion air or ventilated combustion air and the instructions for installing the vent system with the vent terminating as shown in Figures 13 or 14. The two-pipe system must have a separate combustion air pipe and a separate vent pipe for each furnace. Under NO circumstances can the two combustion air or vent pipes be tied together. The combustion air and vent pipes must terminate in the same atmospheric zone.

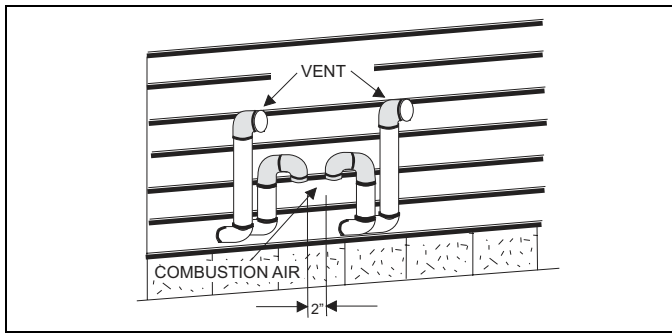

**FIGURE 13:** Double Horizontal Sealed Combustion Air and Vent Termination

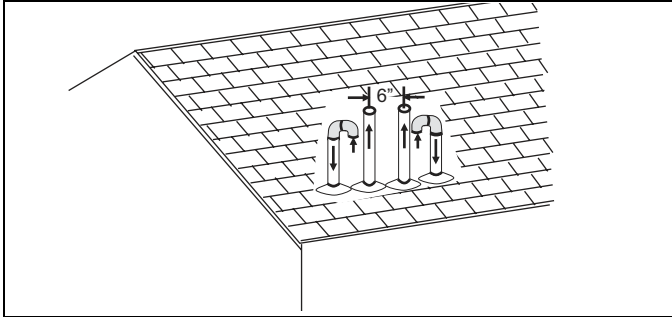

**FIGURE 14:** Double Vertical Sealed Combustion Air and Vent Termination

## COMBUSTION AIR SUPPLY

All installations must comply with Section 5.3, Air for Combustion and Ventilation of the National Fuel Gas Code, ANSI Z223.1 or Sections 7.2, 7.3 or 7.4 of CAN/CGA B149.1 or .2 Installation Code - latest editions.

This furnace is certified to be installed with one of three possible combustion air intake configurations.

1. **OUTDOOR COMBUSTION AIR:** This is a sealed combustion air configuration where the combustion air is supplied through a PVC or ABS pipe that is connected to the PVC coupling attached to the burner box and is terminated in the same atmospheric zone as the vent. This type of installation is approved on all models. Refer to Figure 15.
2. **AMBIENT COMBUSTION AIR:** Combustion air is supplied from the area surrounding the furnace through vents or knockouts in the furnace casing. The combustion air and the vent pipes are not terminated in the same atmospheric zone. Refer to Figure 10 for vent terminations. Refer to "AIR SOURCE FROM INSIDE THE BUILDING" and "VENT AND SUPPLY AIR SAFETY CHECK" for proper installation. Refer to Figure 16.
3. **VENTILATED COMBUSTION AIR:** Combustion air is supplied through a PVC or ABS pipe that is connected to the PVC coupling attached to the burner box and is terminated in a ventilated attic or crawl space. The combustion air and the vent pipes are not terminated in the same atmospheric zone. Refer to Figure 18 for attic and crawl space termination. Only the combustion air intake may terminate in the attic. The vent must terminate outside.

### Outdoor Combustion Air

#### Combustion Air Intake/Vent Connections

This installation requires combustion air to be brought in from outdoors. This requires a properly sized pipe (Shown in Figure 15) that will bring air in from the outdoors to the furnace combustion air intake collar on the burner box. The second pipe (Shown in Figure 15) is the furnace vent pipe.

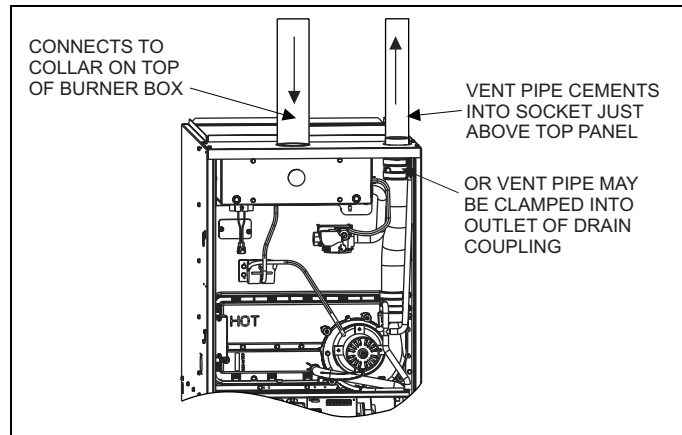

**FIGURE 15:** Sealed Combustion Air Intake Connection and Vent Connection

The combustion air intake pipe should be located either through the wall (horizontal or side vent) or through the roof (vertical vent). Care should be taken to locate side vented systems where trees or shrubs will not block or restrict supply air from entering the terminal.

Also, the terminal assembly should be located as far as possible from a swimming pool or a location where swimming pool chemicals might be stored. Be sure the terminal assembly follows the outdoor clearances listed in Section #1 "Outdoor Air Contaminants."

### Ambient Combustion Air Supply

This type installation will draw the air required for combustion from within the space surrounding the appliance and from areas or rooms adjacent to the space surrounding the appliance. This may be from within the space in a non-confined location or it may be brought into the furnace area from outdoors through permanent openings or ducts. It is not piped directly into the burner box. A single, properly sized pipe from the furnace vent connector to the outdoors must be provided. For upflow models combustion air is brought into the furnace through the unit top panel opening. Do not install a pipe into the intake collar on top of the burner box. Refer to Figure 16.

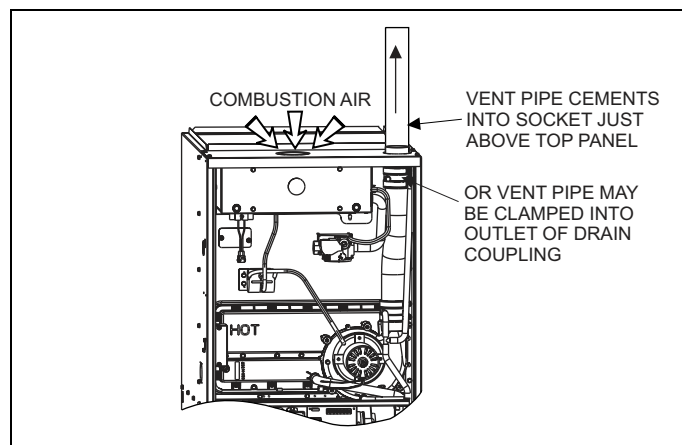

**FIGURE 16:** Combustion Airflow Path Through The Furnace Casing

An **unconfined space** is not less than 50 cu.ft (1.42 m<sup>3</sup>) per 1,000 Btu/hr (0.2928 kW) input rating for all of the appliances installed in that area.

Rooms communicating directly with the space containing the appliances are considered part of the unconfined space, if openings are not furnished with doors.

A **confined space** is an area with less than 50 cu.ft (1.42 m<sup>3</sup>) per 1,000 Btu/hr (0.2928 kW) input rating for all of the appliances installed in that area. The following must be considered to obtain proper air for combustion and ventilation in confined spaces.



**WARNING**

This type of installation requires that the supply air to the appliance(s) be of a sufficient amount to support all of the appliance(s) in the area. Operation of a mechanical exhaust, such as an exhaust fan, kitchen ventilation system, clothes dryer or fireplace may create conditions requiring special attention to avoid unsatisfactory operation of gas appliances. A venting problem or a lack of supply air will result in a hazardous condition, which can cause the appliance to soot and generate dangerous levels of CARBON MONOXIDE, which can lead to serious injury, property damage and / or death.

**Combustion Air Source From Outdoors**

The blocking effects of louvers, grilles and screens must be given consideration in calculating free area. If the free area of a specific louver or grille is not known, refer to Table 10, to estimate free area.

**TABLE 10: Estimated Free Area**

Wood or Metal Louvers or Grilles	Wood 20-25%* Metal 60-70% *
Screens+	1/4" (0.635 cm) mesh or larger 100%

- \* Do not use less than 1/4" (0.635 cm) mesh.
- + Free area of louvers and grille varies widely; the installer should follow louver or grille manufacturer's instructions.

**Dampers, Louvers and Grilles (Canada Only)**

1. The free area of a supply air opening shall be calculated by subtracting the blockage area of all fixed louvers grilles or screens from the gross area of the opening.
2. Apertures in a fixed louver, a grille, or screen shall have no dimension smaller than 0.25" (6.4 mm).
3. A manually operated damper or manually adjustable louvers are not permitted for use.

4. A automatically operated damper or automatically adjustable louvers shall be interlocked so that the main burner cannot operate unless either the damper or the louver is in the fully open position

**TABLE 11: Free Area**

BTUH Input Rating	Minimum Free Area Required for Each Opening		
	Horizontal Duct (2,000 BTUH)	Vertical Duct or Opening to Outside (4,000 BTUH)	Round Duct (4,000 BTUH)
40,000	20 sq. in. (51cm)	10 sq. in. (25 cm)	4" (10 cm)
60,000	30 sq. in. (76 cm)	15 sq. in. (38 cm)	5" (13 cm)
80,000	40 sq. in. (102 cm)	20 sq. in. (51 cm)	5" (13 cm)
100,000	50 sq. in. (102 cm)	25 sq. in. (64 cm)	6" (15 cm)
120,000	60 sq. in. (152 cm)	30 sq. in. (76 cm)	7" (18 cm)

**EXAMPLE: Determining Free Area.**  
 Appliance 1Appliance 2Total Input  
 100,000 + 30,000 = (130,000 ÷ 4,000) = 32.5 Sq. In. Vertical  
 Appliance 1Appliance 2Total Input  
 100,000 + 30,000 = (130,000 ÷ 2,000) = 65 Sq. In. Horizontal

**TABLE 12: Unconfined Space Minimum Area in Square Inch**

BTUH Input Rating	Minimum Free Area Required for Each Opening
40,000	250 (635 cm <sup>2</sup> )
60,000	375 (953 cm <sup>2</sup> )
80,000	500 (1270 cm <sup>2</sup> )
100,000	625 (1588 cm <sup>2</sup> )
120,000	750 (1905 cm <sup>2</sup> )

**EXAMPLE: Square feet is based on 8 foot ceilings.**  
 $\frac{28,000 \text{ BTUH}}{1,000} \times 50 \text{ Cubic Ft.} = \frac{1,400}{8' \text{ Ceiling Height}} = 175 \text{ Sq. Ft.}$

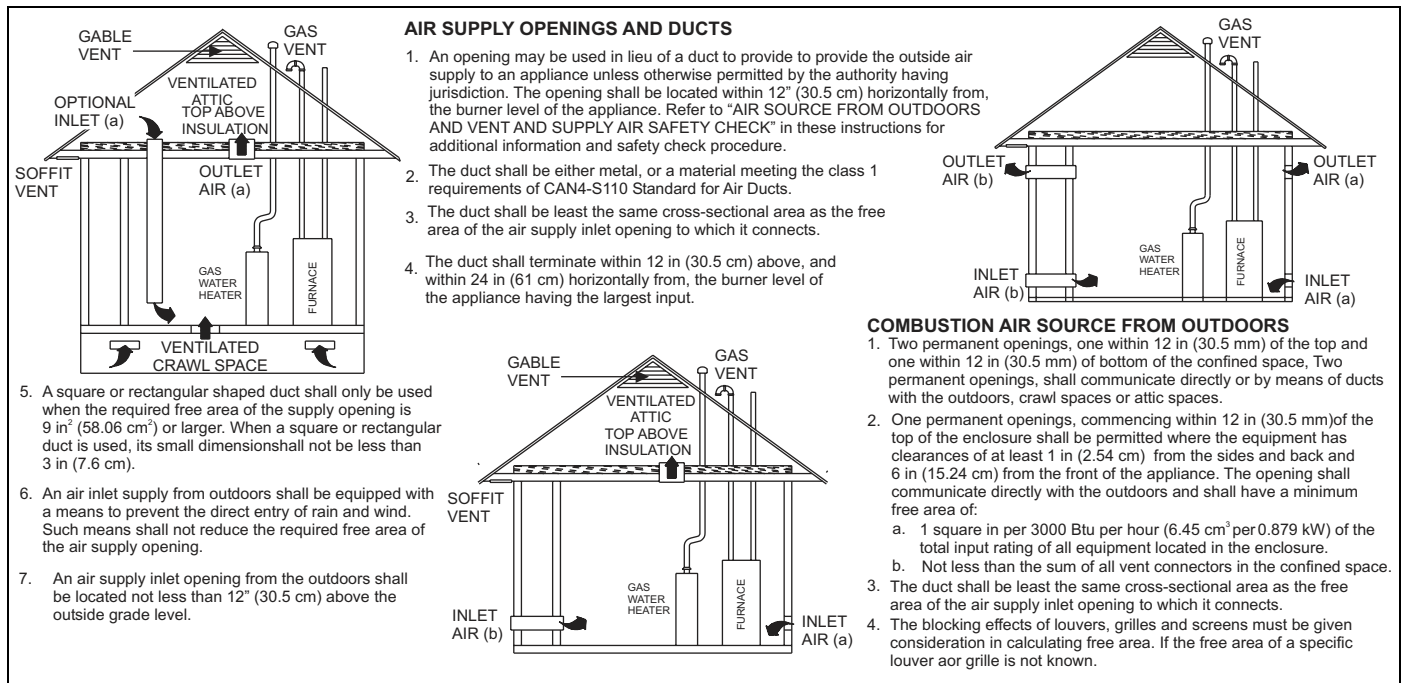

**FIGURE 17: Outside and Ambient Combustion Air**

## Vent and Supply (Outside) Air Safety Check Procedure

Follow the procedure in ANSI Z223.1 National Fuel Gas Code. Refer to the section on the "Recommended Procedure for Safety Inspection of an Existing Appliance" or in Canada B149.1-00 Natural Gas and Propane Installation Code section on "Venting Systems and Air Supply for Appliances" and all local codes. In addition to the procedure specified in ANSI Z223.1, it is recommended that you follow the venting safety procedure below. This procedure is designed to detect an inadequate ventilation system that can cause the appliances in the area to operate improperly causing unsafe levels of Carbon Monoxide or an unsafe condition to occur.

1. Inspect the venting system for proper size and horizontal pitch. Determine that there is no blockage, restriction, leakage, corrosion or other deficiencies, which could cause an unsafe condition.
2. Close all building doors and windows and all doors.
3. Turn on clothes dryers and TURN ON any exhaust fans, such as range hoods and bathroom exhausts, so they shall operate at maximum speed. Open the fireplace dampers. Do not operate a summer exhaust fan.
4. Follow the lighting instructions. Place the appliance being inspected in operation. Adjust thermostat so the appliance shall operate continuously.
5. Test each appliance (such as a water heater) equipped with a draft hood for spillage (down-draft or no draft) at the draft hood relief opening after 5 minutes of main burner operation. Appliances that do not have draft hoods need to be checked at the vent pipe as close to the appliance as possible. Use a combustion analyzer to check the CO<sub>2</sub> and CO levels of each appliance. Use a draft gauge to check for a downdraft or inadequate draft condition.
6. After it has been determined that each appliance properly vents when tested as outlined above, return doors, windows, exhaust fans, fireplace dampers and any other gas burning appliance to their normal condition.
7. If improper venting is observed during any of the above tests, a problem exists with either the venting system or the appliance does not have enough combustion air (Supply Air from outside) to complete combustion. This condition must be corrected before the appliance can function safely.

**NOTE:** An unsafe condition exists when the CO reading exceeds 100 ppm and the draft reading is not in excess of - 0.1 in. W.C. (-25 kPa) with all of the appliance(s) operating at the same time.

8. Any corrections to the venting system and / or to the supply (outside) air system must be in accordance with the National Fuel Gas Code Z223.1 or CAN/CGA B149.1-00 Natural Gas and Propane Installation Code (latest editions). If the vent system must be resized, follow the appropriate tables in Appendix G of the above codes or for this appliance only refer to Table 9 of these instructions.

## Ventilated Combustion Air

The ventilated attic space or a crawl space from which the combustion air is taken must comply with the requirements specified in "AIR SOURCE FROM OUTDOORS" in this instruction or in Section 5.3, Air for Combustion and Ventilation of the National Fuel Gas Code, ANSI Z223.1 (latest edition). This type installation requires two properly sized pipes. One brings combustion air from a properly ventilated attic space or crawl space and a second pipe that extends from the furnace vent connection (top right of unit) to the exterior of the building. Refer to Table 9 for intake pipe sizing, allowable length and elbow usage. Follow all notes, procedures and required materials in the SEALED COMBUSTION AIR SUPPLY section in these instructions when installing the combustion air pipe from the unit and into a ventilated attic space or crawl space. **DO NOT** terminate vent pipe in an Attic or Crawl Space.

## Ventilated Combustion Air Termination

Refer to Figure 18 for required attic termination for the combustion air intake pipe. For attic termination, use two 90 elbows with the open end in a downward position. Be sure to maintain 12" (30 cm) clearance above any insulation, flooring or other material.

A crawl space combustion air installation consists of a straight pipe from the PVC coupling on the burner box that extends into the crawl space and terminates with a 1/4" (6.35 mm) mesh screen and no elbows.

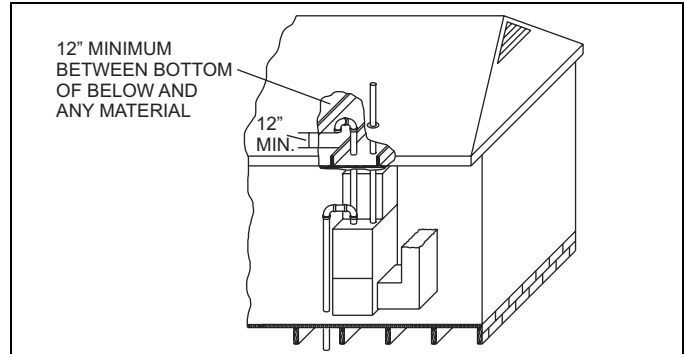

FIGURE 18: Attic and Crawl Space Combustion Air Termination

## Specially Engineered Installations

The above requirements shall be permitted to be waived where special engineering, approved by the authority having jurisdiction, provides an adequate supply of air for combustion and ventilation.

## WARNING

*Be sure to instruct the owner not to block this intake pipe.*

## SECTION VII: CONDENSATE PIPING

The condensate drain connection is provided in the furnace for field installation. It consists of a formed hose with a 1/2" (1.3 cm) NPT male connection. A 1/2" (1.3 cm) FM x 3/4" (1.9 cm) PVC slip coupling is provided.

This drain hose may be installed to allow left or right side condensate drain connection, refer to Figure 19. Cut the hose to allow for proper fit for left or right exit. If necessary, trim the hose supplied to ensure that it slopes downwards.

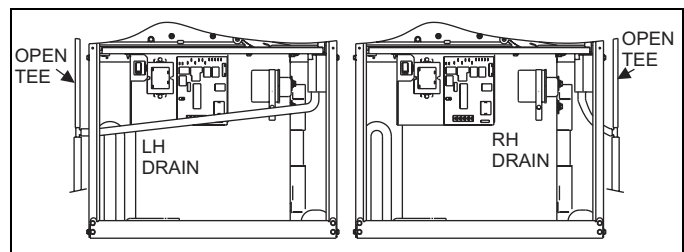

FIGURE 19: Condensate Piping

To install the drain hose assembly, remove the 7/8" (2.2 cm) knockout in the side panel. Remove the conduit nut from the 1/2" (1.3 cm) male fitting. Push the male fitting through the hole and reinstall the nut. The use of the 3/4" (1.9 cm) PVC coupling is optional.

The condensate water will flow to the drain better if an open tee, or short length of pipe is installed in the drain line, as shown in Figure 19.

**IMPORTANT:** The condensate drain from the furnace may be connected in common with the drain from an air conditioning coil if allowed by local code.

**IMPORTANT:** Condensate must be disposed of properly. Follow local plumbing or wastewater codes. The drain line must maintain a 1/4" per foot (0.635 cm per meter) slope to the drain.

## CONDENSATE DRAIN

The condensate trap must be filled with water before putting the furnace into operation. Perform the following procedures only after the condensate trap has been properly piped to a drain connection using the procedure in this instruction.

The recommended procedure is as follows:

1. Disconnect the condensate drain hose from the induced draft blower discharge.
2. Elevate this hose and fill with water using a funnel.
3. Replace the condensate drain hose and clamps.

**IMPORTANT:** If this procedure is not followed, the unit may not properly drain on initial start up.

## CONDENSATE DRAIN TERMINATION

DO NOT terminate condensate drain in a chimney, or where the drain line may freeze. The line must terminate at an inside drain to prevent freezing of the condensate and possible property damage.

DO NOT trap the drain line at any other location than at the condensate drain trap supplied with the furnace.

A condensate sump pump **MUST** be used if required by local codes, or if no indoor floor drain is available. The condensate sump pump must be approved for use with acidic condensate.

## CONDENSATE DRAIN TRAP AND DRAIN FREEZE PROTECTION

Special precautions **MUST** be made if installing furnace in an area which may drop below freezing. This can cause improper operation or damage to the equipment. If the furnace is installed in an area that has the potential of freezing, the drain line and the drain trap must be protected. Use a 3 to 6 watt per foot (0.003 to 0.006 kW per meter) at 115 vac, 40° F (4.4° C) self-regulating, shielded and waterproof heat tape. Wrap the drain trap and the drain line with the heat tape and secure with ties. Follow the heat tape manufacturer's recommendations.

## SECTION VIII: SAFETY CONTROLS

### CONTROL CIRCUIT FUSE

A 3-amp fuse is provided on the control circuit board to protect the 24-volt transformer from overload caused by control circuit wiring errors. This is an ATO 3, automotive type fuse and is located on the control board.

### BLOWER DOOR SAFETY SWITCH

This unit is equipped with an electrical interlock switch mounted in the blower compartment. This switch interrupts all power at the unit when the panel covering the blower compartment is removed.

Electrical supply to this unit is dependent upon the panel that covers the blower compartment being in place and properly positioned.

### CAUTION

*Main power to the unit must still be interrupted at the main power disconnect switch before any service or repair work is to be done to the unit. Do not rely upon the interlock switch as a main power disconnect.*

*Blower and burner must never be operated without the blower panel in place.*

### ROLLOUT SWITCH CONTROLS

These controls are mounted on the burner box assembly. If the temperature in the burner box exceeds its set point, the ignition control and the gas valve are de-energized. The operation of this control indicates a malfunction in the combustion air blower, heat exchanger or a blocked vent pipe connection. Corrective action is required. These are manual reset controls that must be reset before operation can continue.

## PRESSURE SWITCHES

This furnace is supplied with two pressure switches which monitor the flow through the combustion air/vent piping system. These switches de-energize the ignition control module and the gas valve if any of the following conditions are present. Refer to Figure 20 for tubing connections.

1. Blockage of combustion air piping or terminal.
2. Blockage of vent piping or terminal.
3. Failure of combustion air blower motor.
4. Blockage of condensate drain piping.

## LIMIT CONTROLS

There is high temperature limit control located on the furnace vestibule panel near the gas valve. This is an automatic reset control that provides over-temperature protection due to reduced airflow. This may be caused by

1. dirty filter,
2. if the indoor fan motor should fail, or
3. Too many supply or return registers closed or blocked off.

The control module will lockout if the limit trips 5 consecutive times within a single call for heat. Control will reset and try ignition again after 1 hour.

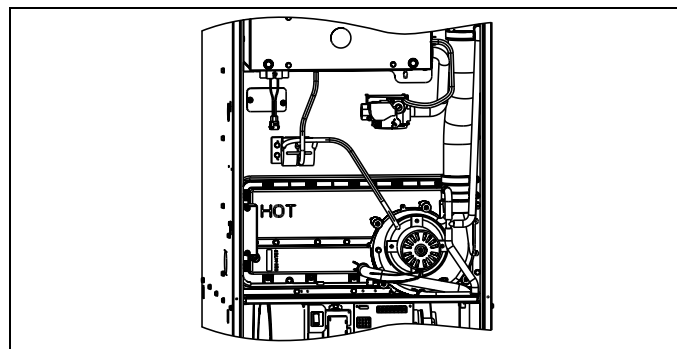

FIGURE 20: Pressure Switch Tube Routing

## SECTION IX: START-UP AND ADJUSTMENTS

The initial start-up of the furnace requires the following additional procedures:

**IMPORTANT:** All electrical connections made in the field and in the factory should be checked for proper tightness.

When the gas supply is initially connected to the furnace, the gas piping may be full of air. In order to purge this air, it is recommended that the ground union be loosened until the odor of gas is detected. When gas is detected, immediately retighten the union and check for leaks. Allow five minutes for any gas to dissipate before continuing with the start-up procedure. Be sure proper ventilation is available to dilute and carry away any vented gas.

### CAUTION

*Perform the following procedures only after the condensate trap has been properly piped to a drain connection using the procedure in this instruction.*

## TOOLS AND INFORMATION THAT WILL BE REQUIRED IN ORDER TO PROPERLY PERFORM THE FURNACE STARTUP PROCEDURE.

1. Call the local gas supplier to obtain heating value of the natural gas. If you cannot obtain the heating value of the gas from the gas supplier, you may use a default value of 1030 BTU/SCF (38.8 MJ / m<sup>3</sup>).
2. You will need a thermometer or portable digital thermometer to read the supply and return air temperatures.
3. You will need a U-tube manometer or digital equipment that has the ability to read pressures between 0 – 15" in.w.c (0 - 3.73 kPa) in order to measure the gas line and the manifold pressures.
4. You will need a 3/32" Allen wrench for the pressure port plugs in the gas valve.
5. You will need 2 pieces of 1/8" (0.3 cm) ID flexible tubing that is 12" (30 cm) in length, 2 – pieces of 1/8" (0.3 cm) tubing that are 4" (10.0 cm) in length, a 1/8" (0.3 cm) tee and a 1/8" (0.3 cm) adapter to connect the U-tube manometer or the digital pressure measuring equipment to the gas valve pressure ports.

There is an accessory kit (1PK0601) available from Source 1, which has the following items:

- 1 - 12" (30 cm) length x 1/8" (0.3 cm) diameter tubing
- 2 – pieces of 4" (10 cm) length x 1/8" (0.3 cm) diameter tubing
- 1 - 5/16" (0.8 cm) tee
- 1 – 5/16" (0.8 cm) x 1/8" (3.175 mm) reducing coupling
- 1 – 1/8" (0.3 cm) adapter

There is a accessory kit (1PK0602) available from Source 1, which has the following items:

- 12" (30 cm) length x 1/8" (0.3 cm) diameter tubing
- 2 – pieces of 4" (10 cm) length x 1/8" (0.3 cm) diameter tubing
- 1 - 5/16" (0.8 cm) tee
- 1 – 5/16" (0.8 cm) x 1/8" (0.3 cm) reducing coupling
- 1 – 1/8" (0.3 cm) adapter
- 1 - Dwyer – Manometer

These items are required in order to properly perform the required start-up procedure.

### IGNITION SYSTEM SEQUENCE

1. Turn the gas supply ON at external valve and main gas valve.
2. Set the thermostat above room temperature to call for heat.
3. System start-up will occur as follows:
  - a. The induced draft blower motor will start and come up to speed. Shortly after inducer start-up, the hot surface igniter will glow for about 17 seconds.
  - b. After this warm up, the ignition module will energize (open) the main gas valve.
  - c. After flame is established, the supply air blower will start in about 30 seconds.

## WARNING

### FIRE OR EXPLOSION HAZARD

*Failure to follow the safety warnings exactly could result in serious injury, death or property damage.*

*Never test for gas leaks with an open flame. Use a commercially available soap solution made specifically for the detection of leaks to check all connections. A fire or explosion may result causing property damage, personal injury or loss of life.*

**IMPORTANT:** Burner ignition may not be satisfactory on first startup due to residual air in the gas line or until gas manifold pressure is adjusted. The ignition control will make 3 attempts to light before locking out.

With furnace in operation, check all of the pipe joints, gas valve connections and manual valve connections for leakage using an approved gas detector, a non-corrosive leak detection fluid, or other leak detection methods. Take appropriate steps to stop any leak. If a leak persists, replace the component.

The furnace and its equipment shutoff valve must be disconnected from the gas supply piping system during any pressure testing of that system at test pressures in excess of 1/2 PSI (3.45 kPa).

The furnace must be isolated from the gas supply piping system by closing the equipment shutoff valve during any pressure testing of the gas supply piping system.

### CALCULATING THE FURNACE INPUT (NATURAL GAS)

**NOTE:** Burner orifices are sized to provide proper input rate using natural gas with a heating value of 1030 BTU/Ft<sup>3</sup> (38.4 MJ/m<sup>3</sup>). If the heating value of your gas is significantly different, it may be necessary to replace the orifices.

**NOTE:** Front door of burner box must be secured when checking gas input.

1. Turn off all other gas appliances connected to the gas meter.
2. At the gas meter, measure the time (with a stop watch) it takes to use 2 cubic ft. (0.0566 m<sup>3</sup>.) of gas.
3. Calculate the furnace input by using one of the following equations.

**In the USA use the following formula to calculate the furnace input.**

For natural gas multiply the heat content of the gas BTU/SCF or Default 1030 BTU/SCF (38.4 MJ/m<sup>3</sup>), times 2 cubic ft. (0.056 m) of gas measured at the gas meter, times a barometric pressure and temperature correction factor of 0.960; times 3600, then divided by the time (In seconds) it took to measure 2 cubic ft. (0.056 m) of gas from the gas meter.

For propane (LP) gas multiply the heat content of the gas BTU/SCF or Default 2500 BTU/SCF (93.15 MJ/m<sup>3</sup>), times 1 cubic ft. (0.028 m) of gas measured at the gas meter, times a barometric pressure and temperature correction factor of 0.960; times 3600, then divided by the time (In seconds) it took to measure 1 cubic ft. (0.028 m) of gas from the gas meter.

**The formula for US input calculation using a cubic foot gas meter:**

$\frac{\text{BTU/ft}^3 \times 2 \text{ cu.ft.} \times 0.960 \times 3600}{\text{Seconds it took to measure the 2 cu.ft. of gas}}$ =	BTU/H	$\frac{\text{BTU/ft}^3 \times 1 \text{ cu.ft.} \times 0.960 \times 3600}{\text{Seconds it took to measure the 1 cu.ft. of gas}}$ =	BTU/H
<b>NATURAL GAS INPUT CALCULATION</b>		<b>PROPANE (LP) GAS INPUT CALCULATION</b>	
EXAMPLE:		EXAMPLE:	
$\frac{1030 \times 2 \times 0.960 \times 3600}{90.5}$ =	78,666.90	$\frac{2500 \times 1 \times 0.960 \times 3600}{108}$ =	80,000.00
Natural Gas		Propane Gas	
1030 BTU/SCF		2500 BTU/SCF	

**In Canada you will use the following formula to calculate the furnace input if you are using a cubic foot gas meter.**

For Natural Gas multiply the Heat content of the gas MJ/m<sup>3</sup> (or Default 38.4), times 2 cubic ft. of gas x 0.028 to convert from cubic feet to cubic meters measured at the gas meter, times a barometric pressure and temperature correction factor of 0.960; times 3600, then divided by the time it took to measure 2 cubic ft. (0.056 m) of gas from the gas meter.

For Propane (LP) Gas multiply the Heat content of the gas MJ/m<sup>3</sup> (or Default 93.15), times 1 cu. ft. of gas x 0.028 to convert from cubic feet to cubic meters measured at the gas meter, times a barometric pressure and temperature correction factor of 0.960; times 3600, then divided by the time it took to measure 1 cubic ft. (0.028 m) of gas from the gas meter.

**The formula for metric input calculation using a cubic foot gas meter:**

$\frac{\text{MJ/m}^3 \times 2 \text{ cu.ft.} \times 0.028 \times 0.960 \times 3600}{\text{Seconds it took to measure the 2 cu.ft. of gas}}$ =	MJ/H	x	0.2777	=	kW	x	3412.14	=	BTU/H
<b>NATURAL GAS INPUT CALCULATION</b>									
EXAMPLE:									
$\frac{38.4 \times 2 \times 0.028 \times 0.960 \times 3600}{90.5}$ =	82.12	x	0.2777	=	22.80	x	3412.14	=	77,796.80
Natural Gas									
1030 BTU/SCF = 38.4 MJ/m <sup>3</sup>									
<b>PROPANE (LP) GAS INPUT CALCULATION</b>									
EXAMPLE:									
$\frac{93.15 \times 1 \times 0.028 \times 0.960 \times 3600}{108}$ =	83.46	x	0.2777	=	23.18	x	3412.14	=	79,093.4
Propane Gas									
2500 BTU/SCF = 93.15 MJ/m <sup>3</sup>									

**In Canada use the following formula to calculate the furnace input if you are using a gas meter that measures cubic meters.**

For Natural Gas multiply the Heat content of the gas MJ/m<sup>3</sup> (or Default 38.4), times 0.10 m<sup>3</sup> of gas measured at the gas meter, times a barometric pressure and temperature correction factor of 0.960; times 3600, then divided by the time it took to measure 0.10 m<sup>3</sup> of gas from the gas meter.

For Propane (LP) Gas multiply the Heat content of the gas MJ/m<sup>3</sup> (or Default 93.15), times 0.10 m<sup>3</sup> of gas measured at the gas meter, times a barometric pressure and temperature correction factor of 0.960; times 3600, then divided by the time it took to measure 0.10 m<sup>3</sup> of gas from the gas meter.

**The formula for metric input calculation using a cubic foot gas meter:**

$\frac{\text{MJ/m}^3 \times \text{m}^3 \times 0.960 \times 3600}{\text{Seconds it took to measure the 0.10 m}^3 \text{ of gas}}$ =	MJ/H	x	0.2777	=	kW	x	3412.14	=	BTU/H
<b>NATURAL GAS INPUT CALCULATION</b>									
EXAMPLE:									
$\frac{38.4 \times 0.1 \times 0.960 \times 3600}{160}$ =	82.94	x	0.2777	=	23.03	x	3412.14	=	78,581.60
Natural Gas									
1030 BTU/SCF = 38.4 MJ/m <sup>3</sup>									
<b>PROPANE (LP) GAS INPUT CALCULATION</b>									
EXAMPLE:									
$\frac{93.15 \times 0.1 \times 0.960 \times 3600}{387}$ =	83.19	x	0.2777	=	23.10	x	3412.14	=	78,826.3
Propane Gas									
2500 BTU/SCF = 93.15 MJ/m <sup>3</sup>									

DO NOT ADJUST the manifold pressure regulator if the actual input is equal to or within 8% less than the furnace input specified on the rating plate or if the furnace rise is above the specified rise range on the rating plate.

If the actual input is significantly higher than the furnace input specified on the rating plate then replace the gas orifices with the gas orifices of the proper size for the type of gas you are using.

For altitudes above 2,000 ft. (610 m) the furnace input MUST BE DERATED. Refer to the GAS CONVERSION FOR PROPANE (LP) AND HIGH ALTITUDES IN SECTION IV for information on high altitude conversions.

## CAUTION

*Be sure to relight any gas appliances that were turned off at the start of this input check.*

**TABLE 13:** Inlet Gas Pressure Range

INLET GAS PRESSURE RANGE		
	Natural Gas	Propane (LP)
Minimum	4.5" W.C. (1.12 kPa)	8.0" W.C. (1.99 kPa)
Maximum	10.5" W.C. (2.61 kPa)	13.0" (3.24 kPa) W.C.

**IMPORTANT:** The inlet gas pressure operating range table specifies what the minimum and maximum gas line pressures must be for the furnace to operate safely.

The gas line pressure **MUST BE**

- 7" W.C. (1.74 kPa) for Natural Gas
- 11" W.C. (2.74 kPa) for Propane (LP) Gas

in order to obtain the BTU input specified on the rating plate and/or the nominal manifold pressure specified in these instructions and on the rating plate.

### ADJUSTMENT OF MANIFOLD GAS PRESSURE

Manifold gas pressure may be measured by two different procedures. It may be measured with the burner box cover in place or it may be measured with the burner box cover removed. Follow the appropriate section in the instructions below. Refer to Figure 21 for a drawing of the locations of the pressure ports on the gas valve.

**Turn gas off at the ball valve or gas cock on gas supply line before the gas valve. Find the pressure ports on the gas valve marked OUT P and IN P.**

1. The manifold pressure must be taken at the port marked OUT P.
2. The inlet gas line pressure must be taken at the port marked IN P.
3. Using a 3/32" (2.4 mm) Allen wrench, loosen the setscrew by turning it 1 turn counter clockwise. **DO NOT REMOVE THE SET SCREW FROM THE PRESSURE PORT.**

**Read the inlet gas pressure using either of the two methods below.**

**Reading the gas pressure with the burner box cover in place:**

- A. Disconnect the pressure reference hose from the right side of the burner box. Using a tee fitting and a short piece of hose, connect the negative side of the manometer to the burner box as described below.
- B. Remove one end the 5/16" (7.94 mm) ID flexible tubing over the pressure port on the burner box.
- C. Insert the end of the 5/16" (7.94 mm) tubing, that has the 1/8" (3.175 mm) adapter at the end of the tube, in to the 1/8" (3.175 mm) tee.
- D. Connect the 1/8" (3.175 mm) tee to the burner box adapter and to the negative side of a U-tube manometer or digital pressure measuring equipment with 2 – 1/8" (3.175 mm) tubes.
- E. Use the 5/16" (7.94 mm x 1/8" (3.175 mm) reducing coupling and a 4" (101.6 mm) piece of 1/8" (3.175 mm) tubing to connect the positive side of the manometer to the gas valve pressure reference port. Refer to Figure 22 for connection details.

**Reading the gas pressure with the burner box cover removed -** Remove the screws securing the burner box front cover plate. Remove the cover. The gasket and may stick in place. Connect the positive side of the manometer to the gas valve as described in E above. There will be no second connection to the manometer, as it will reference atmospheric pressure. Refer to Figure 22 for connection details.

This gas valve has separate regulator adjustment screws for high fire and low fire, as shown in Figure 21. The procedure below is used to adjust either the high fire manifold pressure or the low fire manifold pressure.

**IMPORTANT:** The cap for the pressure regulator must be removed entirely to gain access to the adjustment screw. Loosening or tightening the cap does not adjust the flow of gas.

1. Refer to Figure 21 for location of pressure regulator adjustment cap and adjustment screws on main gas valve.
2. Turn gas and electrical supplies on and follow the operating instructions to place the unit back in operation.
3. Adjust manifold pressure by adjusting gas valve regulator screw for the appropriate gas per the following:

**TABLE 14:** Nominal Manifold Pressure

NOMINAL MANIFOLD PRESSURE	
Natural Gas (High Fire)	3.5" w.c. (0.87 kPa)
Natural Gas (Low Fire)	1.6" w.c. (0.40 kPa)
Propane (LP) Gas (High Fire)	10.0" w.c. (2.488 kPa)
Propane (LP) Gas (Low Fire)	4.0" w.c. (0.99 kPa)

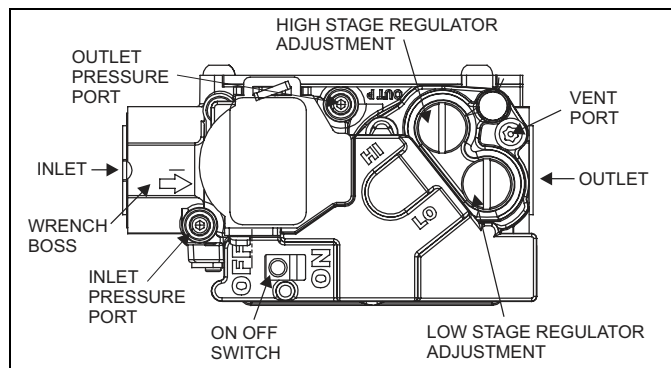

**FIGURE 21:** Gas Valve

**IMPORTANT:** If gas valve regulator is turned in (clockwise), manifold pressure is increased. If screw is turned out (counterclockwise), manifold pressure will decrease.

4. After the manifold pressure has been adjusted, re-calculate the furnace input to make sure you have not exceeded the specified input on the rating plate. Refer to "CALCULATING THE FURNACE INPUT (NATURAL GAS)".
5. Once the correct BTU (kW) input has been established, turn the gas valve to OFF and turn the electrical supply switch to OFF; then remove the flexible tubing and fittings from the gas valve pressure tap and the pressure reference hose from the right side of the burner box and tighten the pressure tap plug using the 3/32" (2.4 mm) Allen wrench. Replace the burner box front cover (if it was removed) and place the pressure reference hose back on the gas valve.
6. Turn the electrical and gas supplies back on, and with the burners in operation, check for gas leakage around the gas valve pressure port for leakage using an approved gas detector, a non-corrosive leak detection fluid, or other leak detection methods.

## WARNING

*The manifold pressure must be checked with the screw-off cap for the gas valve pressure regulator in place. If not, the manifold pressure setting could result in an over-fire condition. A high manifold pressure will cause an over-fire condition, which could cause premature heat exchanger failure. If the manifold pressure is too low, sooting and eventual clogging of the heat exchanger could occur. Be sure that gas valve regulator cap is in place and burner box to gas valve pressure reference hose is connected.*

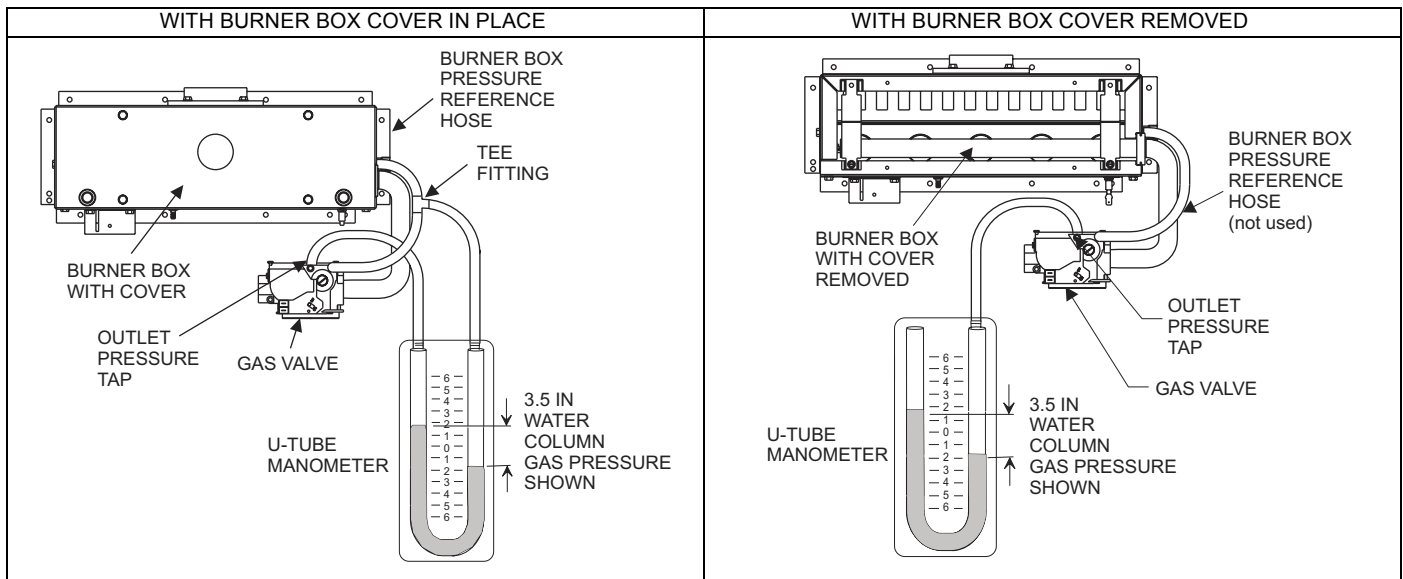

FIGURE 22: Reading Gas Pressure

**ADJUSTMENT OF TEMPERATURE RISE**

**⚠ DANGER**

The temperature rise, or temperature difference between the return air and the supply (heated) air from the furnace, must be within the range shown on the furnace rating plate and within the application limitations shown in Table 7 "ELECTRICAL AND PERFORMANCE DATA".

The supply air temperature cannot exceed the "Maximum Supply Air Temperature" specified in these instructions and on the furnace rating plate. Under NO circumstances can the furnace be allowed to operate above the Maximum Supply Air Temperature. Operating the furnace above the Maximum Supply Air Temperature will cause premature heat exchanger failure, high levels of Carbon Monoxide, a fire hazard, personal injury, property damage, and/or death.

The temperature rise, or temperature difference between the return air and the heated supply air from the furnace, must be within the range shown on the furnace rating plate and within the application limitations shown in Table 7.

After about 20 minutes of operation, determine the furnace temperature rise. Take readings of both the return air and the heated air in the ducts, about six feet (1.83 m) from the furnace where they will not be affected by radiant heat. Increase the blower speed to decrease the temperature rise; decrease the blower speed to increase the rise.

All direct-drive blowers have multi-speed motors. The blower motor speed taps are located in the control box in the blower compartment. Refer to Figure 23, and the unit-wiring label to change the blower speed. To use the same speed tap for heating and cooling, the heat terminal and cool terminal must be connected using a jumper wire and connected to the desired motor lead. Place all unused motor leads on Park terminals. Two are provided.

**⚠ CAUTION**

Do not energize more than one motor speed at a time or damage to the motor will result.

**ADJUSTMENT OF FAN CONTROL SETTINGS**

This furnace is equipped with a time-on/time-off heating fan control. The fan on delay is fixed at 30 seconds. The fan off delay has 4 settings (60, 90, 120 and 180 seconds). The fan off delay is factory set to 120 seconds. The fan-off setting must be long enough to adequately cool the furnace, but not so long that cold air is blown into the heated space. The fan-off timing may be adjusted by positioning the jumper on two of the four pins as shown in Figure 23.

The furnace control board also allows user selection of the blower speed that is energized during continuous fan operation. Place jumper on the HI COOL, LO COOL, or HI HEAT, LO HEAT pins.

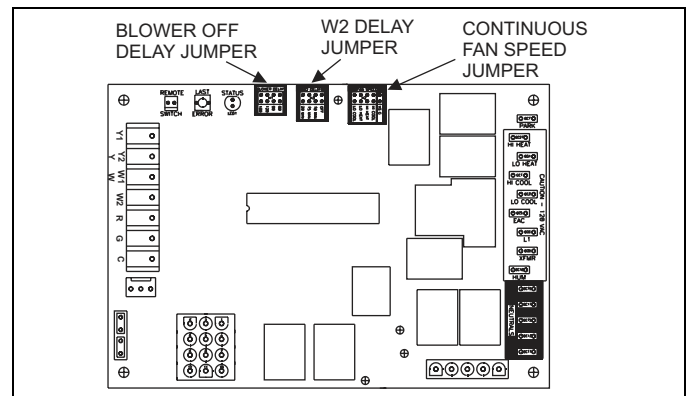

FIGURE 23: Furnace Control Board

TABLE 15: Blower Performance CFM

AIRFLOW WITH BOTTOM OR ONE SIDE RETURN - WITHOUT FILTERS																					
MODELS		EXTERNAL STATIC PRESSURE, INCHES W.C. (kPa)																			
Input/ Airflow/cabinet	Speed Tap	0.1 (0.025)		0.2 (0.050)		0.3 (0.075)		0.4 (0.099)		0.5 (0.124)		0.6 (0.149)		0.7 (0.174)		0.8 (0.199)		0.9 (0.224)		1.0 (0.249)	
		CFM	m <sup>3</sup> /min	CFM	m <sup>3</sup> /min	CFM	m <sup>3</sup> /min	CFM	m <sup>3</sup> /min	CFM	m <sup>3</sup> /min	CFM	m <sup>3</sup> /min	CFM	m <sup>3</sup> /min	CFM	m <sup>3</sup> /min	CFM	m <sup>3</sup> /min	CFM	m <sup>3</sup> /min
40/1200/A	HIGH	1395	40	1330	38	1265	36	1200	34	1120	32	1030	29	940	27	820	23	NR	NR	NR	NR
	M-HI	1025	29	990	28	960	27	925	26	885	25	825	23	750	21	660	19	NR	NR	NR	NR
	M-LO	785	22	765	22	745	21	715	20	670	19	625	18	545	15	NR	NR	NR	NR	NR	NR
	LOW	640	18	605	17	590	17	565	16	530	15	465	13	405	11	NR	NR	NR	NR	NR	NR
80/1200/B 60/1200/B	HIGH	1650	47	1605	45	1570	44	1525	43	1465	41	1410	40	1350	38	1275	36	1170	33	1060	30
	M-HI	1165	33	1185	34	1175	33	1165	33	1150	33	1140	32	1100	31	1050	30	970	27	875	25
	M-LO	895	25	915	26	935	26	940	27	940	27	920	26	905	26	860	24	815	23	750	21
	LOW	710	20	725	21	725	21	725	21	720	20	700	20	685	19	660	19	625	18	560	16
100/2000/C	HIGH	2300	65	2210	63	2120	60	2020	57	1930	55	1830	52	1715	49	1595	45	1480	42	1350	39
	M-HI	1950	55	1900	54	1830	52	1755	50	1680	48	1595	45	1500	42	1390	39	1270	36	1155	33
	M-LO	1610	46	1545	44	1490	42	1440	41	1390	39	1315	37	1230	33	1155	33	1050	30	920	26
	LOW	1325	38	1270	36	1225	35	1175	33	1105	31	1045	30	990	28	905	25	890	25	790	22
100/1600/C 80/1600/C	HIGH	1960	56	1955	55	1925	55	1890	54	1830	52	1765	50	1695	48	1615	46	1600	45	1485	42
	M-HI	1565	44	1560	44	1560	44	1575	45	1545	44	1530	43	1475	42	1425	40	1365	39	1260	36
	M-LO	1230	35	1275	36	1285	36	1300	37	1310	37	1300	37	1280	36	1245	35	1190	34	1070	30
	LOW	930	26	945	27	965	27	975	28	975	28	975	28	975	28	950	27	910	26	850	24
120/2000/D	HIGH	2560	72	2485	70	2410	68	2320	66	2220	63	2135	60	2035	58	1920	54	1785	51	1650	47
	M-HI	2090	59	2050	58	1990	56	1970	56	1885	53	1820	52	1760	50	1675	47	1545	44	1405	40
	M-LO	1695	48	1675	47	1665	47	1615	46	1565	44	1510	43	1460	41	1385	39	1285	36	1140	32
	LOW	1175	33	1150	33	1135	32	1110	31	1085	31	1055	30	1005	28	980	28	970	27	845	24

**AIRFLOW WITH TWO SIDE RETURNS OR WITH BOTTOM AND ONE SIDE RETURN - WITHOUT FILTERS**

MODELS		EXTERNAL STATIC PRESSURE, INCHES W.C. (kPa)																			
Input/ Airflow/cabinet	Speed Tap	0.1 (0.025)		0.2 (0.050)		0.3 (0.075)		0.4 (0.099)		0.5 (0.124)		0.6 (0.149)		0.7 (0.174)		0.8 (0.199)		0.9 (0.224)		1.0 (0.249)	
		CFM	m <sup>3</sup> /min	CFM	m <sup>3</sup> /min	CFM	m <sup>3</sup> /min	CFM	m <sup>3</sup> /min	CFM	m <sup>3</sup> /min	CFM	m <sup>3</sup> /min	CFM	m <sup>3</sup> /min	CFM	m <sup>3</sup> /min	CFM	m <sup>3</sup> /min	CFM	m <sup>3</sup> /min
100/2000/C	HIGH	2465	70	2380	67	2295	65	2195	62	2095	59	1995	56	1875	53	1760	50	1620	46	1470	42
	M-HI	2085	59	2035	58	1960	55	1880	54	1800	51	1705	48	1605	45	1485	42	1360	39	1235	35
	M-LO	1725	49	1625	46	1595	45	1540	44	1485	42	1405	40	1315	37	1235	35	1125	32	995	28
	LOW	1420	40	1360	39	1310	37	1255	36	1180	33	1120	32	1070	30	970	27	950	27	845	24
120/2000/D	HIGH	2615	74	2535	72	2450	69	2385	68	2285	65	2175	62	2075	59	1945	55	1825	52	1670	47
	M-HI	2055	58	2045	58	2015	57	1985	56	1932	55	1855	53	1785	51	1730	49	1605	45	1470	42
	M-LO	1690	48	1650	47	1620	46	1600	45	1570	44	1525	43	1470	42	1395	40	1300	37	1200	34
	LOW	1345	38	1335	38	1335	38	1285	36	1250	35	1230	35	1180	33	1115	32	1010	29	850	24

NOTES:

- Airflow expressed in standard cubic feet per minute (CFM) and in cubic meters per minute (m<sup>3</sup>/min).
- Return air is through side opposite motor (left side).
- In order to stay within the velocity rating the filters, airflows above 1800 CFM (50.97 m<sup>3</sup>/min) require either return from two sides or one side plus bottom.
- Motor voltage at 115 V.
- NR = Operation at this static pressure is not recommended.

**FILTER PERFORMANCE**

The airflow capacity data published in Table 15 represents blower performance WITHOUT filters. To determine the approximate blower performance of the system, apply the filter drop value for the filter being used or select an appropriate value from the Table 16.

**NOTE:** The filter pressure drop values in Table 16 are typical values for the type of filter listed and should only be used as a guideline. Actual pressure drop ratings for each filter type vary between filter manufacturers.

TABLE 16: Filter Performance - Pressure Drop Inches W.C. and (kPa)

AIRFLOW RANGE	MINIMUM OPENING SIZE				FILTER TYPE											
					DISPOSABLE				WASHABLE FIBER*				PLEATED			
	1 Opening		2 Openings		1 Opening		2 Opening		1 Opening		2 Opening		1 Opening		2 Opening	
Sq. in.	m <sup>2</sup>	Sq. in.	m <sup>2</sup>	In w.c.	Pa	In w.c.	Pa	In w.c.	Pa	In w.c.	Pa	In w.c.	Pa	In w.c.	Pa	
0 - 750	230	.15	658	.42	0.01	2.5	0.08	20	0.01	2.5	0.06	15	0.15	37	0.17	42
751 - 1000	330	.21			0.04	10			0.03	7.5			0.20	50		
1001 - 1250	330	.21			0.08	20			0.07	17			0.20	50		
1251 - 1500	330	.21			0.08	20			0.07	17			0.25	62		
1501 - 1750	380	.25	658	.42	0.14	35	0.08	20	0.13	32	0.06	15	0.30	75	0.17	42
1751 - 2000	380	.25	658	.42	0.17	42	0.09	22	0.15	37	0.07	17	0.30	75	0.17	42
2001 & Above	463	.30	658	.42	0.17	42	0.09	22	0.15	37	0.07	17	0.30	75	0.17	42



## APPLYING FILTER PRESSURE DROP TO DETERMINE SYSTEM AIRFLOW

To determine the approximate airflow of the unit with a filter in place, follow the steps below:

1. Select the filter type.
2. Select the number of return air openings or calculate the return opening size in square inches to determine the proper filter pressure drop.
3. Determine the External System Static Pressure (ESP) without the filter.
4. Select a filter pressure drop from the table based upon the number of return air openings or return air opening size and add to the ESP from Step 3 to determine the total system static.
5. If total system static matches a ESP value in the airflow table (i.e. 0.20 w.c. (50 Pa), 0.60 w.c. (150 Pa), etc.) the system airflow corresponds to the intersection of the ESP column and Model/Blower Speed row.
6. If the total system static falls between ESP values in the table (i.e. 0.58 w.c. (144 Pa), 0.75 w.c. (187 Pa), etc.), the static pressure may be rounded to the nearest value in the table determining the airflow using Step 5 or calculate the airflow by using the following example.

Example: For a 120,000 BTUH (38.06 kW) furnace with 2 return openings and operating on high-speed blower, it is found that total system static is 0.58" w.c. To determine the system airflow, complete the following steps:

Obtain the airflow values at 0.50 w.c. (125 Pa) & 0.60 w.c. (150 Pa) ESP.

Airflow @ 0.50": 2285 CFM (64.70 m<sup>3</sup>/min)

Airflow @ 0.60": 2175 CFM (61.59 m<sup>3</sup>/min)

Subtract the airflow @ 0.50 w.c. (125 Pa) from the airflow @ 0.60 w.c. (150 Pa) to obtain airflow difference.

2175 - 2285 = -110 CFM (3.11 m<sup>3</sup>/min)

Subtract the total system static from 0.50 w.c. (125 Pa) and divide this difference by the difference in ESP values in the table, 0.60 w.c. (150 Pa) - 0.50 w.c. (125 Pa), to obtain a percentage.

$(0.58 - 0.50) / (0.60 - 0.50) = 0.8$

Multiply percentage by airflow difference to obtain airflow reduction.

$(0.8) \times (-110) = -88$

Subtract airflow reduction value to airflow @ 0.50 w.c. (125 Pa) to obtain actual airflow @ 0.58 in. wc (144 Pa) ESP.

2285 - 88 = 2197

**TABLE 17:** Field Installed Accessories - Non Electrical

MODEL NO.	DESCRIPTION	USED WITH
1NP0347	PROPANE (LP) CONVERSION KIT	ALL MODELS
1CT0302	CONCENTRIC INTAKE/VENT 2"	40, 60, 80, 100 INPUT MBH
1CT0303	CONCENTRIC INTAKE/VENT 3"	100, 120 MBH
1HT0901	SIDEWALL VENT TERMINATION	ALL MODELS
1PS0501	HIGH ALTITUDE PRESSURE SWITCH KIT (Does Not Include Orifices)	60 MBH
1PS0502		80/1200 MBH
1PS0503		80/1600, 100/1600, 120 MBH
1PS0505		100/2000 MBH
1PS0506		40 MBH
1NK0301		CONDENSATE NEUTRALIZER KIT
1SF0101	EXTERNAL SIDE FILTER RACK	ALL MODELS
1SR0302	SIDE RETURN FILTER KIT 1" FILTER	ALL MODELS
1SR0200	SIDE RETURN FILTER KIT 1-4" FILTER	ALL MODELS
1BR0114	BOTTOM RETURN FILTER KIT 1" FILTER	14-1/2" CABINETS
1BR0214	BOTTOM RETURN FILTER KIT 1-4" FILTER	14-1/2" CABINETS
1BR0117	BOTTOM RETURN FILTER KIT 1" FILTER	17-1/2" CABINETS
1BR0217	BOTTOM RETURN FILTER KIT 1-4" FILTER	17-1/2" CABINETS
1BR0121	BOTTOM RETURN FILTER KIT 1" FILTER	21" CABINETS
1BR0221	BOTTOM RETURN FILTER KIT 1-4" FILTER	21" CABINETS
1BR0124	BOTTOM RETURN FILTER KIT 1" FILTER	24-1/2" CABINETS
1BR0224	BOTTOM RETURN FILTER KIT 1-4" FILTER	24-1/2" CABINETS



---

# NOTES

---

# NOTES