

INSTALLATION INSTRUCTIONS

MODULAR AIR HANDLER
MODEL: N*AH

TABLE OF CONTENTS

GENERAL INFORMATION	2
INSPECTION	2
REFERENCE	2
LIMITATIONS	2
LOCATION	2
DUCT CONNECTIONS	4
SUSPENSION KITS	5
BLOWER / COIL ASSEMBLY UPFLOW AND HORIZONTAL INSTALLATIONS	5
BLOWER / COIL ASSEMBLY DOWNFLOW INSTALLATION	5
ELECTRIC HEATERS & OPERATING CONTROLS ...	6
LOW VOLTAGE CONTROL CONNECTIONS	6
LINE POWER CONNECTIONS	6
BLOWER SPEED CONNECTIONS	6
LUBRICATION	6

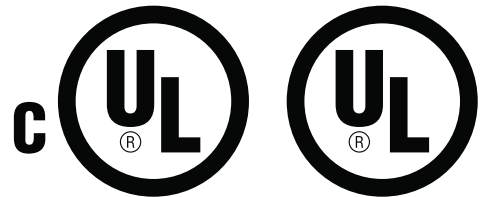

**CAUTION: READ ALL SAFETY GUIDES BEFORE YOU
START TO INSTALL YOUR FURNACE.**

SAVE THIS MANUAL

GENERAL INFORMATION

This Modular Air Handler provides the flexibility for installation in any upflow, downflow or horizontal application. These versatile models may be used with or without electric heat. The direct-drive, 3-speed motors (except D14 which has 4-speeds) provide a selection of air volume to match any application.

BRAND LABEL (in carton envelope) apply to center of blower access panel.

The unit can be positioned for bottom return air in the upflow position, top return air in the downflow position and right or left return in the horizontal position.

Top and side power wiring and control wiring, accessible screw terminals for control wiring, and electric heaters all combine to make the installation easy, and minimize installation cost.

INSPECTION

As soon as a unit is received, it should be inspected for possible damage during transit. If damage is evident, the extent of the damage should be noted on the carrier's delivery receipt. A separate request for inspection by the carrier's agent should be made in writing. See Local Distributor for more information.

Also check to be sure all accessories such as heater kits, suspension kits, and coils are available. Installation of these accessories or field conversion of the unit should be accomplished before setting the unit in place or connecting any wiring, electric heat, ducts or piping.

REFERENCE

This instruction should be used in conjunction with instructions supplied with each accessory as well as matching outdoor section.

Installer should pay particular attention to the words: NOTE, CAUTION, and WARNING.

NOTES are intended to clarify or make the installation easier.

CAUTIONS identifies procedure which, if not followed carefully, could result in personal injury, property damage or product damage.

WARNINGS are given to alert the installer that severe personal injury, death or equipment damage may result if installation procedures are not handled properly.

LIMITATIONS

These units must be wired and installed in accordance with all national and local safety codes.

Voltage limits are as follows:

Air Handler Voltage	Voltage code	¹ Normal Operating Voltage Range
208/230-1-60	06	187-253
460-3-60	46	432-504
220/240-1-50	93	198-264

- ¹ Rated in accordance with ARI Standard 110, utilization range "A".

Airflow must be within the minimum and maximum limits approved for electric heat, evaporator coils and outdoor units.

Entering Air Temperature Limits			
Wet Bulb Temp. °F		Dry Bulb Temp. °F	
Min.	Max.	Min.	Max.
57	72	65	95

LOCATION

Location is usually predetermined. Check with owner's or dealer's installation plans. If location has not been decided, consider the following in choosing a suitable location:

1. Select a location with adequate structural support, space for service access, clearance for air return and supply duct connections.
2. Use hanging brackets to wall mount unit as shown below.
3. Normal operating sound levels may be objectionable if the air handler is placed directly over some rooms such as bedrooms, study, etc.
4. Precautions should be taken to locate the unit and ductwork so that supply air does not short circuit to the return air.
5. Select a location that will permit installation of condensate line to an open drain.

NOTE: When the coil is installed in a draw-thru application, it is recommended to trap the primary and secondary drain line. If the secondary drain line is not used, it must be capped.

The coil is provided with a secondary drain. It should be piped to a location that will give the occupant a visual warning that the primary drain is clogged. If the secondary drain is not used it must be capped.

6. When an evaporator coil is installed in an attic or above a finished ceiling, an auxiliary drain pan should be provided under the coil as is specified by most local building codes.
7. Proper electrical supply must be available.
8. Clearances must also be taken into consideration, and provided for as follows:
 - a. Refrigerant piping and connections are located in the front.
 - b. Maintenance and servicing through the front or access side of unit with both sides and rear of unit having zero inch clearance.
 - c. Condensate drain lines are connected in the front (clear of filter).
 - d. Filter removal.
 - e. When no electric heat is used, the unit as well as all duct work and plenum are designed for zero clearance to combustible materials.

CAUTION

If electric heat is used, a minimum clearance of 1" must be maintained on all sides of the supply air duct and/or plenum continuously for up to 3' (See Figure 2).

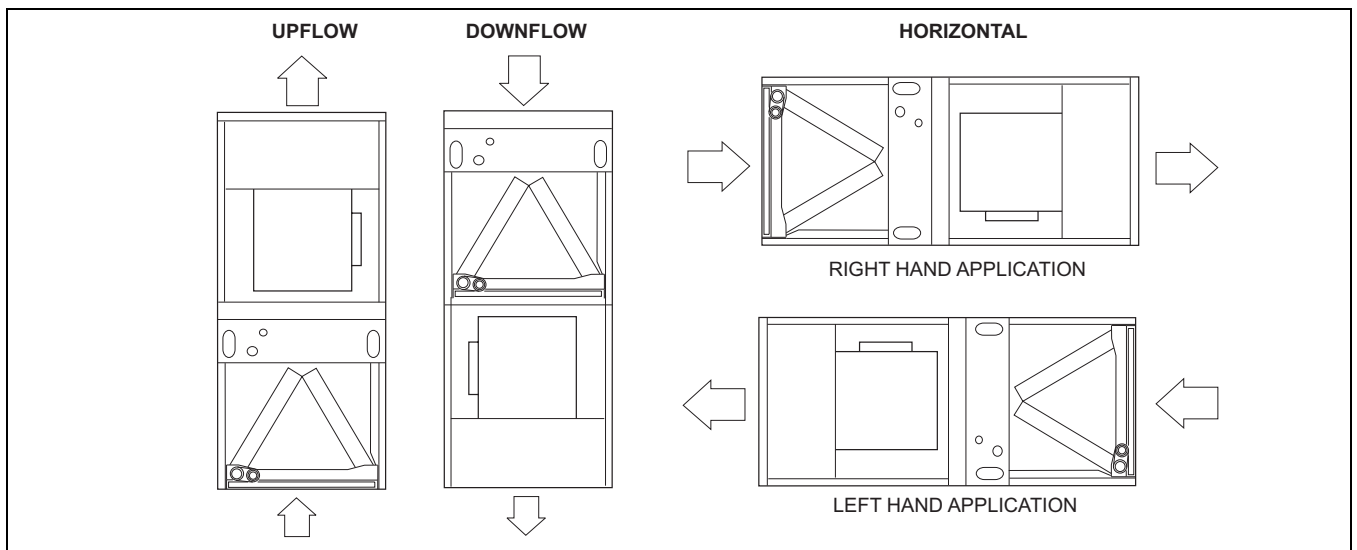

FIGURE 1 : Typical Applications with G2FD Multi-Position Coils

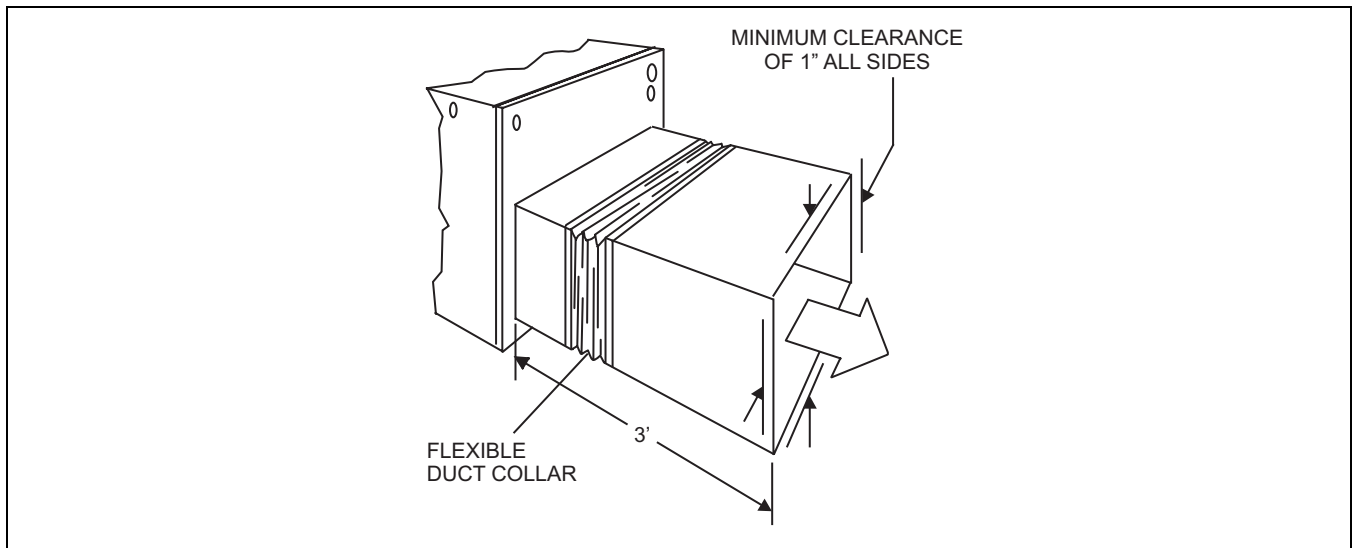

FIGURE 2 : Plenum Clearances

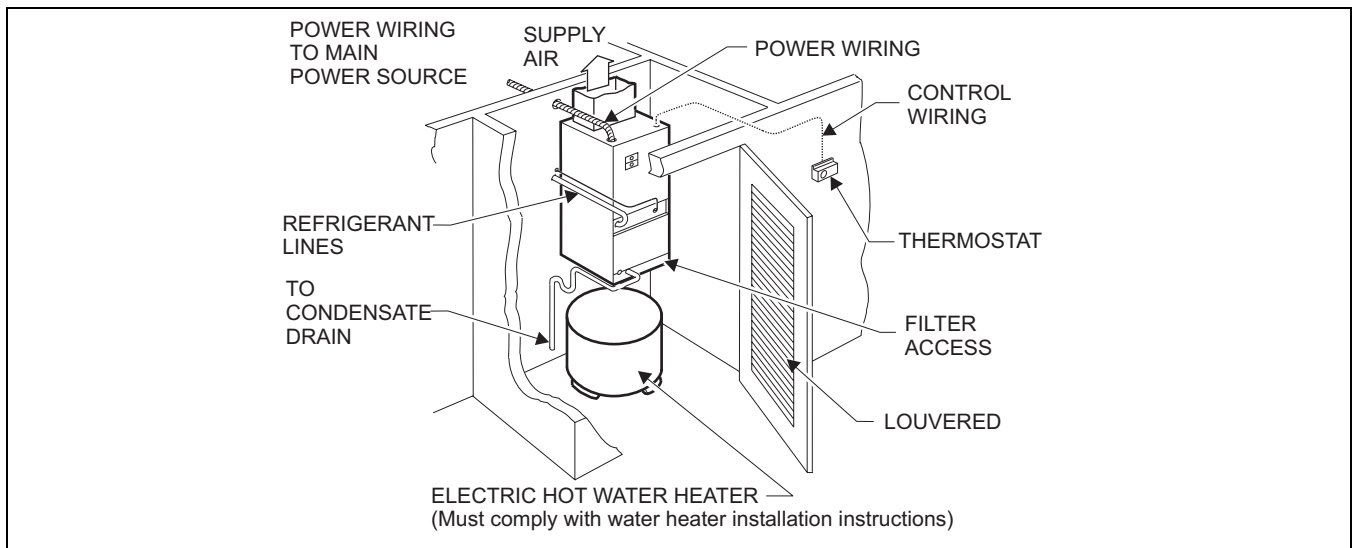

FIGURE 3 : Typical Upflow Installation

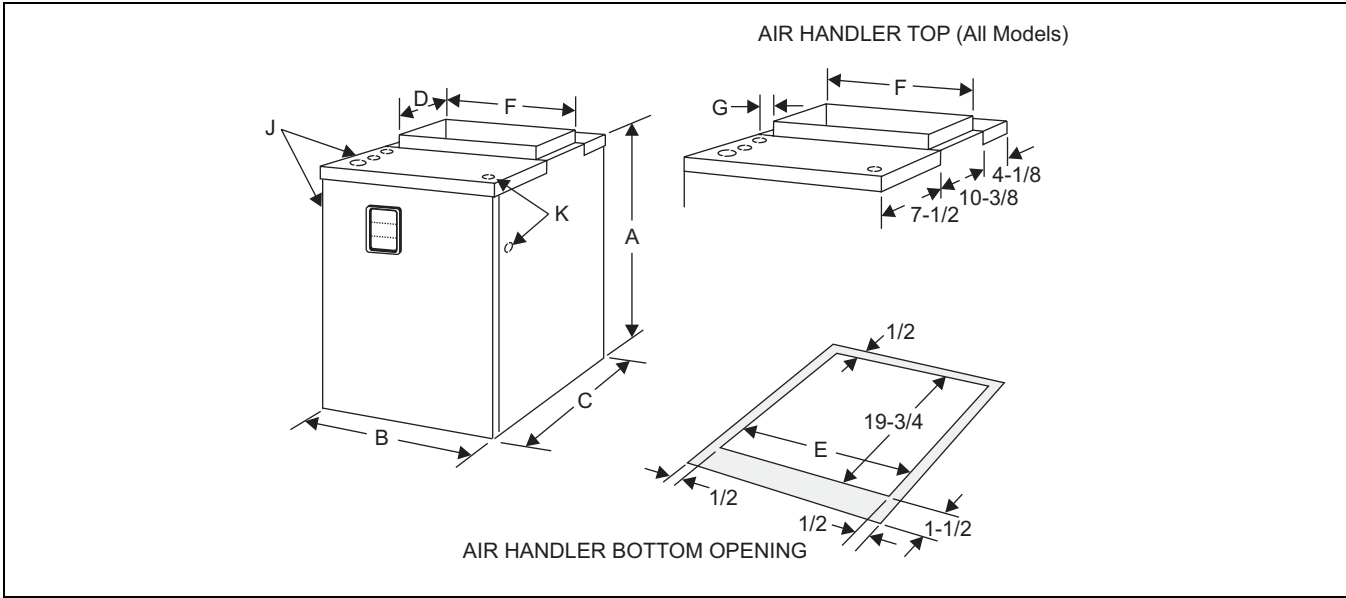

FIGURE 4 : Dimensions & Duct Sizes

N1AH MODEL	DIMENSIONS - INCHES							WIRING K.O.S*	
	A	B	C	D	E	F	G	J	K
	HEIGHT	WIDTH	DEPTH					POWER	CONTROL
B08	24 - 1/4	17-1/2	22	10 - 3/8	16-1/2	16-1/2	1/2	7/8 (1/2) 1-3/8 (1)	7/8 (1/2)
B12		17-1/2			16-1/2	16-1/2	1/2	7/8 (1/2) 1-3/8 (1)	
C16		21			20	20	1/2	7/8 (1/2) 1-3/8 (1) 1-23/32 (1-1/4)	
D14		24-1/2			23-1/2	22-1/2	1	7/8 (1/2) 1-3/8 (1)	
D20		24-1/2			23-1/2	22-1/2	1	1-31/32 (1-1/2)	

*NOTE: Actual conduit size is shown in brackets.

DUCT CONNECTIONS

NOTE: The electric heat accessory should be installed before the supply air duct is attached to the supply air openings. Refer to the electric heater kit instructions for proper installation.

Air supply and return may be handled in one of several ways best suited to the installation (See Figure 4 for dimensions for duct inlet and outlet connections).

The vast majority of problems encountered with combination heating and cooling systems can be linked to improperly designed or installed duct systems. It is therefore highly important to the success of an installation that the duct system be properly designed and installed.

Use flexible duct collars to minimize the transmission of vibration/noise into the conditioned space. If electric heat is used non-flammable material must be used.

Where return air duct is short, or where sound is liable to be a problem, sound absorbing glass fiber should be used inside the duct. Insulation of duct work is a must where it runs through an unheated space during the heating season or through an uncooled space during the cooling season. The use of a vapor barrier is recommended to prevent absorption of moisture from the surrounding air into the insulation.

The supply air duct should be properly sized by use of a transition to match unit opening. All ducts should be suspended using flexible hangers and never fastened directly to the structure. This unit is not designed for non-ducted (freeblow) applications. Size outlet plenum or transition to discharge opening sizes shown in Figure 4.

Duct work should be fabricated and installed in accordance with local and/or national codes. This includes the standards of the National Fire Protection Association for Installation of Air-Conditioning and Ventilating Systems, NFPA No. 90B.

SUSPENSION KITS

A suspension kit is available. Models 1BH0601 is designed specifically for the units contained in this instruction (upflow application only). For installation of these accessory kits, see the instructions packed with the kit.

For suspension of these units in horizontal applications, it is recommended to use angle support brackets with threaded rods, supporting the units from the bottom, at the locations shown in Figure 5.

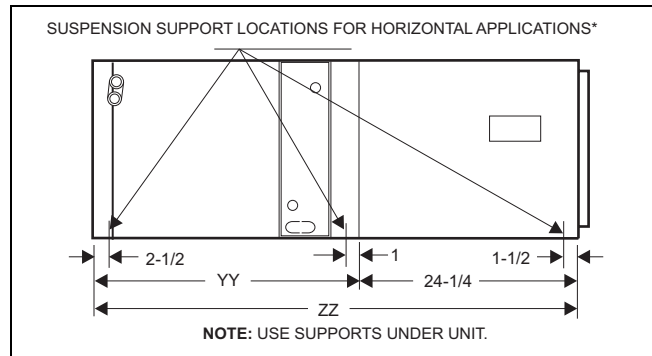

FIGURE 5 :

*G2FD	Dimension		*G2FD	Dimension	
	YY	ZZ		YY	ZZ
024S17	23	47-3/8	036S21	23	47-3/8
030S17	23	47-3/8	042S21	23	47-3/8
036S17	28	52-3/8	048S21	28	52-3/8
046S17	28	52-3/8	048S24	28	52-3/8
-	-	-	060S24	28	52-3/8

* Full Cased Coil Model Number

BLOWER / COIL ASSEMBLY UPFLOW AND HORIZONTAL INSTALLATIONS

NOTE: See coil instructions prior to assembly for drain pan installation or baffle adjustment.

1. Apply neoprene gasket provided in instruction packet to top of coil.
2. Position blower casing over coil opening.

NOTE: Tie plate and screws are provided with all full-cased coils.

3. Align the six holes provided and attach tie plate to back of casings using screws provided.
4. Remove blower access panel.
5. Fasten duct flanges of coil to duct flanges of air handler with screws. See Figure 6.
6. Secure toe plate of blower to top panel of coil using 2 screws provided.
7. See sections on electrical and blower speed connections.
8. Re-position and replace access panel.

BLOWER / COIL ASSEMBLY DOWNFLOW INSTALLATION

1. Position blower casing over duct connection and secure such that the supply air end of the blower is down.

CAUTION

Blowers with an electric heater kit must include a non-combustible floor base if installing on a combustible floor. See instructions for 1FB0617, 1FB0621 and 1FB0624.

2. Apply neoprene gasket provided in instruction packet to return-air side of air handler.
3. Place coil casing over blower return opening.
4. Align the six holes provided and attach tie plate to back of casings using screws provided.

NOTE: Tie plate and screws are included with all full cased coils.

5. Remove blower access panel and coil filter door.
6. Secure the two toe plates of the blower section and coil using provided holes and 2 screws.
7. See sections on electrical and blower speed connections.
8. Re-position and replace access panel and filter door.

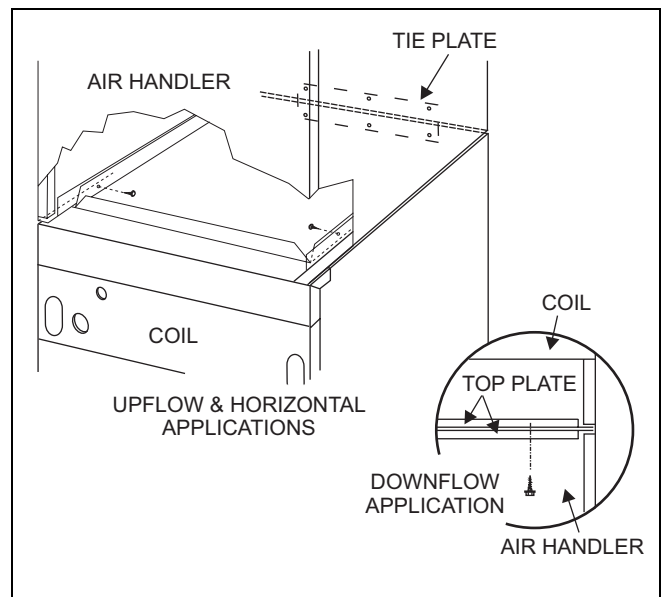

FIGURE 6 : Tie Plate & Fastening Tabs

ELECTRIC HEATERS & OPERATING CONTROLS

The low voltage transformer and the fan / heater control are standard on all models. The air handlers are shipped pre-wired to operate as cooling only applications. To complete the installation for cooling only, install a 6-pin jumper plug to the control board to bypass the heater limit controls. This jumper plug is secured to the duct cover near the 4-pin power plug harness or is in the customer packet. Failure to install the plug will cause the blower to run continuously. See Figure 7. Mark the unit nameplate with the appropriate heater selection on the space provided or NONE to indicate cooling only.

To operate these units with electric heat, it is necessary to field install an electric heater kit (2HK). See Electric Heater Accessory Installation instructions for proper installation procedure. Prior to installing electric heat, it is necessary to perform the following procedure:

1. Remove the 4-pin power plug from the control board (See Figure 7).

NOTE: This pin must not be used when electric heaters are installed.

2. Remove the four (4) screws from the duct cover and remove the duct cover from the air handler.

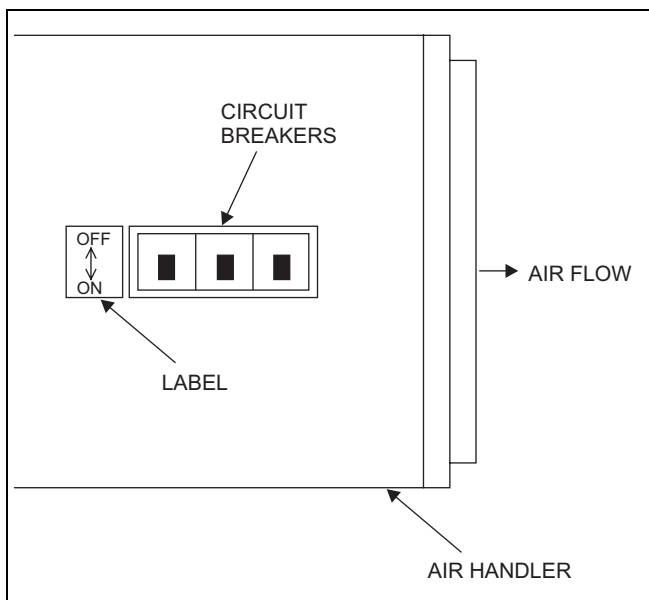

FIGURE 7 :

For units with heaters with circuit breakers in a horizontal right application, a label must be applied to the unit to describe the circuit breaker orientation. The label is included in the installation instruction packet. See Figure 7.

LOW VOLTAGE CONTROL CONNECTIONS

The 24 volt power supply is provided by an internally wired low voltage transformer which is standard on all models. However, if the unit is connected to a 208 volt power supply the low voltage transformer must be rewired to the 208 volt tap. See the unit wiring label.

Field supplied low voltage wiring can exit the unit on the top right hand corner or the right hand side panel (see Figure 4, item K).

Install the 7/8" plastic bushing supplied with the unit in the selected hole and keep low voltage wiring as short as possible inside the control box.

The field wiring is to be connected at the screw terminals of the control board (Refer to Figures 11, 12, 13 and 14).

NOTE: All wiring must comply with local and national electrical code requirements. Read and heed all unit caution labels.

NOTE: It is possible to vary the amount of electric heat turned on during the defrost cycle of a heat pump. Standard wiring will only bring on 5 - 10 KW of electric heat during defrost, depending on the size of the heater.

LINE POWER CONNECTIONS

Power may be brought into the unit through the supply air end of the unit (top when unit is vertical) or the left side panel. Use the hole appropriate to the unit's orientation in each installation to bring conduit from the disconnect. The power lead conduit should be terminated at the electrical control box. Refer to Tables 5,6,7 and 10 thru 15 for wire requirements. Also see Figure 8.

BLOWER SPEED CONNECTIONS

All air handlers, except N1AHD1406 (which is 4-speed), contain three speed blower motors which are pre-wired to the control board.

Adjust blower motor speed to provide airflow within the minimum and maximum limits approved for evaporator coil, electric heat and outdoor unit. Speed tap adjustments are made at the motor terminal block (See Figure 10, Blower Speed Connections). Airflow data is shown in Table 16.

Indoor air volume should be adjusted to 375 - 400 CFM per ton of cooling for optimum performance.

Connect motor wires to motor speed tap receptacle for speed desired. See wiring label for motor wiring details (See Figure 10).

The unit control is designed for the addition of a 2-speed fan kit. See accessory for details.

LUBRICATION

The bearings of the blower motor are permanently lubricated.

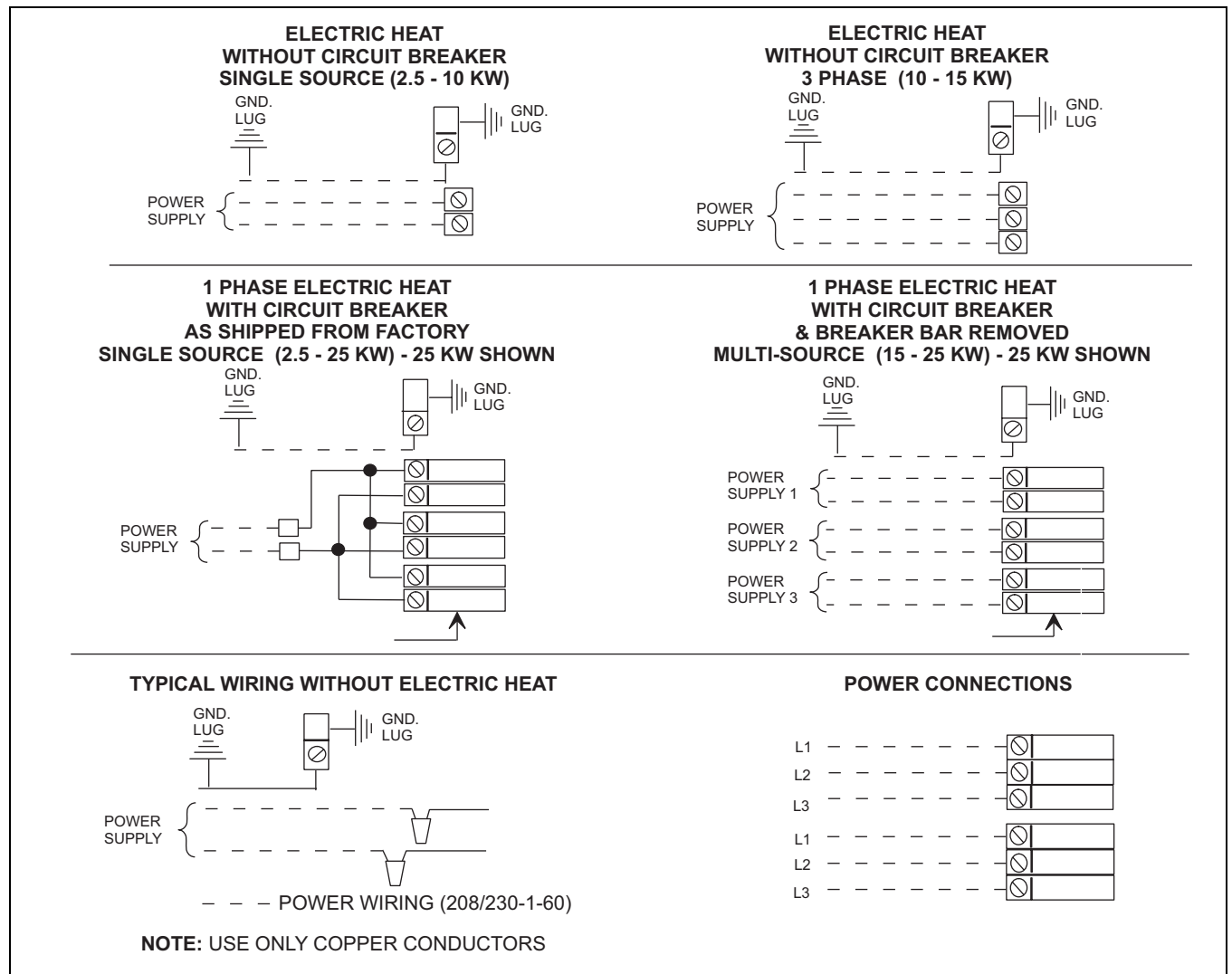

FIGURE 8 : Line Power

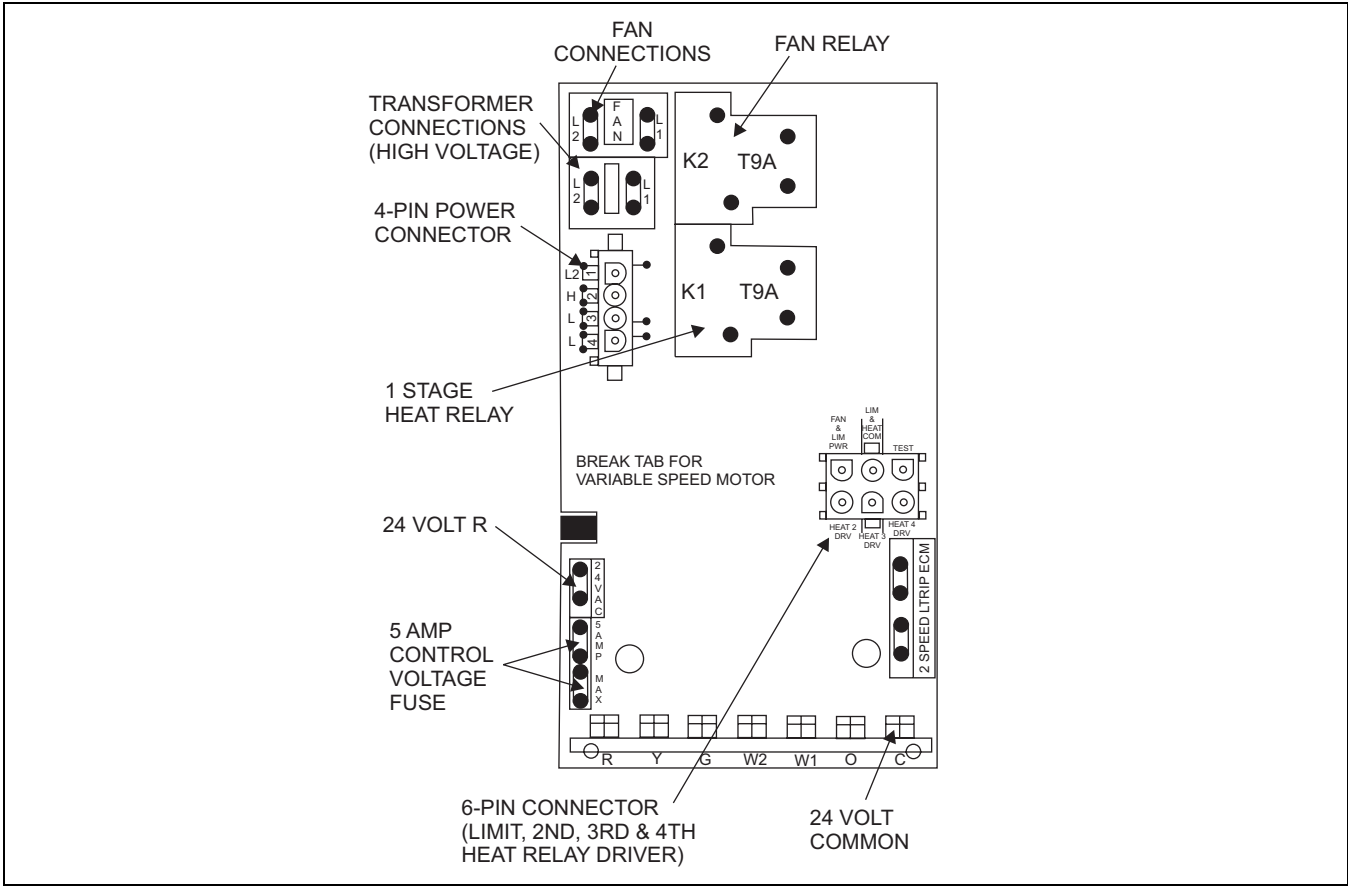

FIGURE 9 : Control Board

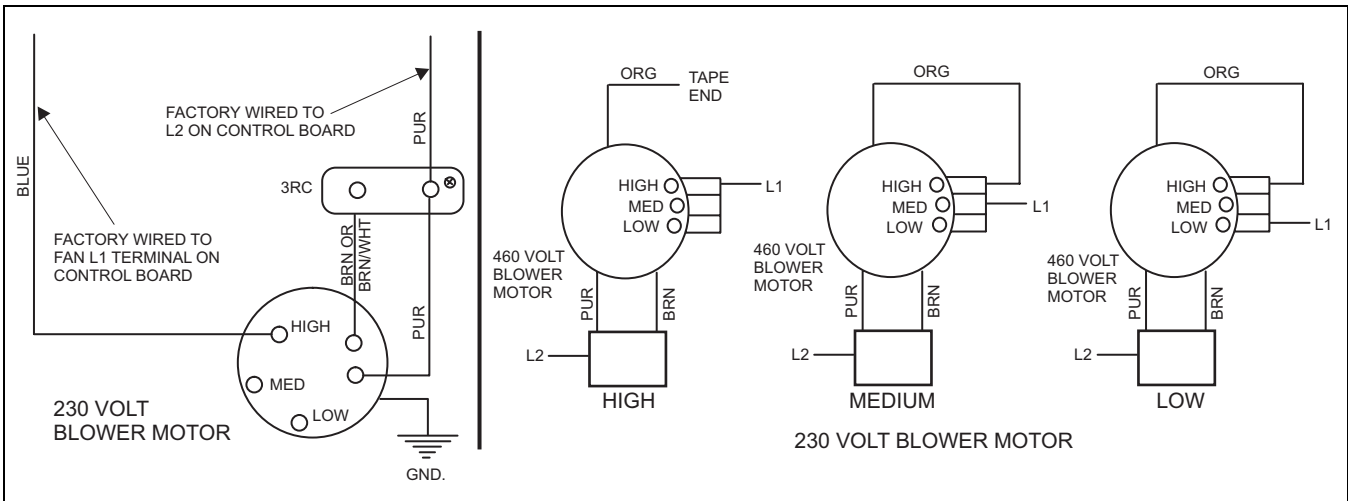

FIGURE 10 : Blower Speed Connections

Table 1: PHYSICAL AND ELECTRICAL DATA

MODEL N1AH		B08	B12			C16			D14	D20		
		06	06	93	46	06	93	46	06	06	93	46
Blower - Diameter x Width		10 x 6	10 x 8	10 x 8	10 x 8	11 x 10	11 x 10	11 x 10	10 x 10	11 x 10	11 x 10	11 x 10
Motor	HP	1/4	1/2	1/2	1/2	1/2	1/2	1/2	1/3	3/4	3/4	3/4
	Nominal RPM	1075	1075	1350	1049	1085	1350	974	1075	1100	1065	1065
Voltage		208/230	208/230	220/240	460	208/230	220/240	460	208/230	208/230	220/240	460
Amps	Full Load	1.6 / 1.4	3.3 / 2.9	2.3	1.6	3.8/3.3	2.4	1.8	3.0 / 2.7	5.1 / 4.4	5.7	2.3
	Locked Rotor	3.3 / 2.9	7.4 / 6.5	5.4	3.3	4.6 / 4.0	4.9	2.6	4.8 / 4.1	8.4 / 7.3	7.7	4.5
Shipping / Operating Weight (lbs.)		60/54	66/60	66/60	66/60	73/67	73/67	73/67	89 / 83	91/85	91/85	91/85

KW & MBH CONVERSIONS - FOR TOTAL POWER INPUT REQUIREMENT

FOR	208V	OPERATION MULTIPLY	240V	TABULATED KW & MBH BY	.751
	230V		240V		.918
	220V		240V		.840

Table 2: ELECTRICAL DATA - 208/230-1-60¹

N1AH MODEL	HEATER MODEL*	MIN. CFM & MAX. STATIC		TOTAL HEAT ²				KW STAGING**					
				KW		MBH		W1 ONLY		W2 ONLY		W1 + W2	
		STATIC	TAP	208	240	208	240	208	240	208	240	208	240
B0806	2HK*6500206B	0.5	LO	1.9	2.5	6.5	8.5	1.9	2.5	1.9	2.5	1.9	2.5
	2HK*6500506B		LO	3.8	5.0	13.0	17.1	3.8	5.0	3.8	5.0	3.8	5.0
	2HK*6500806B		LO	5.6	7.5	19.1	25.6	3.8	5.0	5.6	7.5	5.6	7.5
	2HK*6501006B		LO	7.5	10.0	25.6	34.1	3.8	5.0	7.5	10.0	7.5	10.0
B1206	2HK*6500506B	0.5	LO	3.8	5.0	13.0	17.1	3.8	5.0	3.8	5.0	3.8	5.0
	2HK*6500806B		LO	5.6	7.5	19.1	25.6	3.8	5.0	5.6	7.5	5.6	7.5
	2HK*6501006B		LO	7.5	10.0	25.6	34.1	3.8	5.0	7.5	10.0	7.5	10.0
	2HK16501506B		MED	11.3	15.0	38.6	51.2	3.8	5.0	7.5	10.0	11.3	15.0
	2HK16501806B		HI	13.2	17.6	45.1	60.1	3.8	5.0	8.5	11.3	13.2	17.6
	2HK16501906B		HI	13.2	17.6	45.1	60.1	2.8	3.8	10.4	13.8	13.2	17.6
C1606	2HK*6500506B	0.5	LO	3.8	5.0	13.0	17.1	3.8	5.0	3.8	5.0	3.8	5.0
	2HK*6500806B		LO	5.6	7.5	19.1	25.6	3.8	5.0	5.6	7.5	5.6	7.5
	2HK*6501006B		LO	7.5	10.0	25.6	34.1	3.8	5.0	7.5	10.0	7.5	10.0
	2HK16501506B		LO	11.3	15.0	38.6	51.2	3.8	5.0	7.5	10.0	11.3	15.0
	2HK16502006B		HI	15.0	20.0	51.2	68.3	3.8	5.0	7.5	10.0	15.0	20.0
D1406	2HK*6500506B	0.5	LO	3.8	5.0	13.0	17.1	3.8	5.0	3.8	5.0	3.8	5.0
	2HK*6500806B		LO	5.6	7.5	19.1	25.6	3.8	5.0	5.6	7.5	5.6	7.5
	2HK*6501006B		MED-HI	7.5	10.0	25.6	34.1	3.8	5.0	7.5	10.0	7.5	10.0
	2HK16501506B		HI	11.3	15.0	38.6	51.2	3.8	5.0	7.5	10.0	11.3	15.0
D2006	2HK06500806B	0.5	LO	5.6	7.5	19.1	25.6	3.8	5.0	5.6	7.5	5.6	7.5
	2HK06501006B		LO	7.5	10.0	25.6	34.1	3.8	5.0	7.5	10.0	7.5	10.0
	2HK16501506B		LO	11.3	15.0	38.6	51.2	3.8	5.0	7.5	10.0	11.3	15.0
	2HK16502006B		LO	15.0	20.0	51.2	68.3	3.8	5.0	7.5	10.0	15.0	20.0
	2HK16502506B		LO	18.8	25.0	64.2	85.3	3.8	5.0	11.3	15.0	18.8	25.0
	2HK16503006A		HI	22.5	30.0	76.8	102.4	7.5	10.0	15.0	20.0	22.5	30.0

1. Heat KW shown at 240V represents maximum heater rating. See conversion table above for voltage multiplier.

2. See conversion table above.

* May be 0 (no breaker) or 1 (with breaker).

** If first stage heat or 66 is connected to W1, otherwise refer to Table 5.

Table 3: ELECTRICAL DATA - 208/230-3-60¹

N1AH MODEL	HEATER MODEL*	MIN. CFM & MAX. STATIC		TOTAL HEAT ¹				KW STAGING**					
		STATIC	TAP	KW		MBH		W1 ONLY		W2 ONLY		W1 + W2	
				208	240	208	240	208	240	208	240	208	240
B0806	2HK06501025B	0.5	LO	7.5	10.0	25.6	34.1	3.8	5.0	7.5	10.0	7.5	10.0
B1206	2HK06501025B		LO	7.5	10.0	25.6	34.1	3.8	5.0	7.5	10.0	7.5	10.0
	2HK06501525B		MED	11.3	15.0	38.6	51.2	3.8	5.0	7.5	10.0	11.3	15.0
	2HK06501825B		HI	13.2	17.6	45.1	60.1	3.8	5.0	8.5	11.3	13.2	17.6
C1606	2HK06501025B		LO	7.5	10.0	25.6	34.1	3.8	5.0	7.5	10.0	7.5	10.0
	2HK06501525B		LO	11.3	15.0	38.6	51.2	3.8	5.0	7.5	10.0	11.3	15.0
	2HK06501825B		LO	13.2	17.6	45.1	60.1	3.8	5.0	8.5	11.3	13.2	17.6
D1406	2HK06501025B		MED-HI	7.5	10.0	25.6	34.1	3.8	5.0	7.5	10.0	7.5	10.0
	2HK06501525B		HI	11.3	15.0	38.6	51.2	3.8	5.0	7.5	10.0	11.3	15.0
	2HK06501025B		LO	7.5	10.0	25.6	34.1	3.8	5.0	7.5	10.0	7.5	10.0
D2006	2HK06501525B		LO	11.3	15.0	38.6	51.2	3.8	5.0	7.5	10.0	11.3	15.0
	2HK06501825B		LO	13.2	17.6	45.1	60.1	3.8	5.0	8.5	11.3	13.2	17.6
	2HK16503025A	HI	22.5	30.0	76.8	102.4	7.5	10.0	15.0	20.0	22.5	30.0	

¹ Heat KW shown at 240V represents maximum heater rating. See conversion table above for voltage multiplier.

** If first stage heat or 66 is connected to W1, otherwise refer to Table 5.

Table 4: ELECTRICAL DATA - 460-3-60

N1AH MODEL	HEATER MODEL*	MIN. CFM & MAX. STATIC		FAN FLA 460	TOTAL HEAT ¹			KW STAGING		
		STATIC	TAP		KW	MBH	W1 ONLY	W2 ONLY	W1 + W2	
					480V	480V	480V	480V	480V	
B1246	2HK06501046B	0.5	LO	1.6	9.4	32.1	4.7	9.4	9.4	
	2HK06501546B		HI	1.6	14.1	48.1	4.7	14.1	14.1	
C1646	2HK06501046B		LO	1.8	9.4	32.1	4.7	9.4	9.4	
	2HK06501546B		LO	1.8	14.1	48.1	4.7	14.1	14.1	
D2046	2HK06501046B		LO	2.3	9.4	32.1	4.7	9.4	9.4	
	2HK06501546B		LO	2.3	14.1	48.1	4.7	14.1	14.1	
	2HK06502946B		HI	2.3	28.2	96.2	9.4	18.8	28.2	

¹ See Conversion Table on page 5.*

2HK0 = No Breaker - 2HK1 = Breaker

Table 5: ELECTRICAL DATA (FOR SINGLE SOURCE) - COPPER WIRE 208/230-1-60¹

N1AH MODEL	HEATER MODEL*	HEATER AMPS 240V	FIELD WIRING					
			MIN. CIRCUIT AMPACITY		MAX. O.C.P. ² AMPS/TYPE		WIRE SIZE - AWG	
			208V	240V	208V	240V	208V	240V
B0806	2HK*6500206B	10.4	13.3	14.6	15	15	14	14
	2HK*6500506B	20.8	24.7	27.7	25	30	10	10
	2HK*6500806B	31.3	35.5	40.7	40	45	8	8
	2HK*6501006B	41.7	46.9	53.7	50	60	8	6
B1206	2HK*6500506B	20.8	26.8	29.5	30	30	10	10
	2HK*6500806B	31.3	37.7	42.6	40	45	8	8
	2HK*6501006B	41.7	49.1	55.6	50	60	8	6
	2HK16501506B	62.5	71.9	81.6	80	90	4	3
	2HK16501806B	73.3	83.3	95.2	90	100	4	3
C1606	2HK16501906B	73.3	83.3	95.2	90	100	3	3
	2HK*6500506B	20.8	27.6	30.2	30	35	10	8
	2HK*6500806B	31.3	38.4	43.2	40	45	8	8
	2HK*6501006B	41.7	49.8	56.2	50	60	8	6
	2HK16501506B	62.5	72.7	82.3	80	90	4	3
D1406	2HK16502006B	83.3	94.9	108.3	100	110	3	2
	2HK*6500506B	20.8	26.6	29.3	30	30	10	10
	2HK*6500806B	31.3	37.4	42.3	40	45	8	8
	2HK*6501006B	41.7	48.8	55.3	50	60	8	6
	2HK16501506B	62.5	71.7	81.4	80	90	4	3
D2006	2HK*6500806B	31.3	39.8	44.3	40	45	8	8
	2HK*6501006B	41.7	51.2	57.3	60	60	6	6
	2HK16501506B	62.5	74.0	83.4	80	90	4	3
	2HK16502006B	83.3	96.3	109.4	100	110	3	2
	2HK16502506B	104.2	119.1	135.5	125	150	1	1/0
2HK16503006A	125.0	141.3	161.5	150	175	1/0	2/0	

¹ Heat amps shown at 240V represents maximum heater rating.

² OCP = Over current protection.

* May be 0 (no breaker) or 1 (with breaker).

Table 6: ELECTRICAL DATA (FOR SINGLE SOURCE POWER SUPPLY) - COPPER WIRE 208/230-3-60¹

N1AH MODEL	HEATER MODEL*	FIELD WIRING					
		MIN. CIRCUIT AMPACITY		MAX. O.C.P. ² AMPS/TYPE		WIRE SIZE - AWG 75°C	
		208V	240V	208V	240V	208V	240V
B0806	2HK06501025B	41.2	46.5	45	50	8	8
B1206	2HK06501025B	43.1	48.2	45	50	8	8
	2HK06501525B	43.1	48.2	45	50	8	8
	2HK06501825B	47.7	53.5	50	60	8	6
C1606	2HK06501025B	43.7	48.7	45	50	8	8
	2HK06501525B	43.7	48.7	45	50	8	8
	2HK06501825B	48.6	54.3	50	60	8	6
D1406	2HK06501025B	42.8	47.9	45	50	8	8
	2HK06501525B	42.8	47.9	45	50	8	8
D2006	2HK06501025B	45.0	49.7	50	50	8	8
	2HK06501525B	45.0	49.7	50	50	8	8
	2HK06501825B	48.7	55.4	50	60	8	6

NOTE: 30 KW 3 Ø not approved for single source power supply.

- Heat amps shown at 240V represents maximum heater rating.
- OCP = Over current protection.

Table 7: ELECTRICAL DATA (FOR SINGLE SOURCE POWER SUPPLY) - COPPER WIRE 460-3-60

N1AH MODEL	HEATER MODEL*	FIELD WIRING		
		MIN. CIRCUIT AMPACITY 480V	MAX. O.C.P. ² AMPS/TYPE 480V	WIRE SIZE - AWG 75°C 480V
B1246	2HK06501046B	20.8	25	10
	2HK06501546B	23.1	25	10
C1646	2HK06501046B	21.0	25	10
	2HK06501546B	23.3	25	10
D2046	2HK06501046B	21.5	25	10
	2HK06501546B	23.9	25	10
	2HK06502946B	45.1	50	8

* 2HK0 = No Breaker - 2HK1 = Breaker

² O.C.P. = Over-Current Protection

Table 8: ELECTRICAL DATA - 220/240-1-50

N1AH MODEL	HEATER MODEL*	MIN. CFM & MAX. STATIC		TOTAL HEAT ¹				KW STAGING					
				KW		MBH		W1 ONLY		W2 ONLY		W1 + W2	
		STATIC	TAP	220V	240V	220V	240V	220V	240V	220V	240V	220V	240V
B1293	2HK*6500506B	0.5	LO	4.2	5.0	14.3	17.1	4.2	5.0	4.2	5.0	4.2	5.0
	2HK*6500806B		LO	6.3	7.5	21.5	25.6	4.2	5.0	6.3	7.5	6.3	7.5
	2HK*6501006B		LO	8.4	10.0	28.7	34.1	4.2	5.0	8.4	10.0	8.4	10.0
	2HK16501506B		MED	12.6	15.0	43.0	51.2	4.2	5.0	8.4	10.0	12.6	15.0
	2HK16501806B		MED	14.8	17.6	50.5	60.1	4.2	5.0	9.5	11.3	14.8	17.6
	2HK16501906B		HI	14.8	17.6	50.5	60.1	3.2	3.8	11.6	13.8	14.8	17.6
	2HK*6500506B		LO	4.2	5.0	14.3	17.1	4.2	5.0	4.2	5.0	4.2	5.0
C1693	2HK*6500806B	0.5	LO	6.3	7.5	21.5	25.6	4.2	5.0	6.3	7.5	6.3	7.5
	2HK*6501006B		LO	8.4	10.0	28.7	34.1	4.2	5.0	8.4	10.0	8.4	10.0
	2HK16501506B		LO	12.6	15.0	43.0	51.2	4.2	5.0	8.4	10.0	12.6	15.0
	2HK16502006B		HI	16.8	20.0	57.3	68.3	4.2	5.0	8.4	10.0	16.8	20.0
	2HK*6500806B		LO	6.3	7.5	21.5	25.6	4.2	5.0	6.3	7.5	6.3	7.5
D2093	2HK*6501006B	0.5	LO	8.4	10.0	28.7	34.1	4.2	5.0	8.4	10.0	8.4	10.0
	2HK16501506B		LO	12.6	15.0	43.0	51.2	4.2	5.0	8.4	10.0	12.6	15.0
	2HK16502006B		LO	16.8	20.0	57.3	68.3	4.2	5.0	8.4	10.0	16.8	20.0
	2HK16502506B		LO	21.0	25.0	71.7	85.3	4.2	5.0	12.6	15.0	21.0	25.0
	2HK16503006A		HI	25.2	30.0	86.0	102.4	8.4	10.0	16.8	20.0	25.2	30.0
	2HK*6500506B		LO	4.2	5.0	14.3	17.1	4.2	5.0	4.2	5.0	4.2	5.0

¹ See Conversion Table on page 9.

* 2HK0 = No Breaker - 2HK1 = Breaker

Table 9: ELECTRICAL DATA - 220/240-3-50

N1AH MODEL	HEATER MODEL*	MIN. CFM & MAX. STATIC		TOTAL HEAT ¹				KW STAGING					
				KW		MBH		W1 ONLY		W2 ONLY		W1 + W2	
		STATIC	TAP	220V	240V	220V	240V	220V	240V	220V	240V	220V	240V
B1293	2HK06501025B	0.5	LO	8.4	10.0	28.7	34.1	4.2	5.0	8.4	10.0	8.4	10.0
	2HK06501525B		MED	12.6	15.0	43.0	51.2	4.2	5.0	8.4	10.0	12.6	15.0
	2HK06501825B		MED	14.8	17.6	50.5	60.1	4.2	5.0	9.5	11.3	14.8	17.6
C1693	2HK06501025B		LO	8.4	10.0	28.7	34.1	4.2	5.0	8.4	10.0	8.4	10.0
	2HK06501525B		LO	12.6	15.0	43.0	51.2	4.2	5.0	8.4	10.0	12.6	15.0
	2HK06501825B		MED	14.8	17.6	50.5	60.1	4.2	5.0	9.5	11.3	14.8	17.6
D2093	2HK06501025B		LO	8.4	10.0	28.7	34.1	4.2	5.0	8.4	10.0	8.4	10.0
	2HK06501525B		LO	12.6	15.0	43.0	51.2	4.2	5.0	8.4	10.0	12.6	15.0
	2HK06501825B		LO	14.8	17.6	50.5	60.1	4.2	5.0	9.5	11.3	14.8	17.6
	2HK16503025A	HI	25.2	30.0	86.0	102.4	8.4	10.0	16.8	20.0	25.2	30.0	

¹ See Conversion Table on page 9.

* 2HK0 = No Breaker - 2HK1 = Breaker

Table 10: - ELECTRICAL DATA (FOR SINGLE SOURCE POWER SUPPLY) COPPER WIRE 220/240-1-50

N1AH MODEL	HEATER MODEL*	FIELD WIRING						
		HEATER AMPS	MIN. CIRCUIT AMPACITY		MAX. O.C.P. ² AMPS/TYPE		WIRE SIZE - AWG 75°C	
			240V	220V	240V	220V	240V	220V
B1293	2HK*6500506B	20.8	27.0	28.9	30	30	10	10
	2HK*6500806B	31.3	38.9	41.9	40	45	8	8
	2HK*6501006B	41.7	50.9	55.0	60	60	8	6
	2HK16501506B	62.5	74.7	81.0	80	90	4	3
	2HK16501806B	73.3	87.2	94.5	90	100	3	3
	2HK16501906B	73.3	87.2	94.5	90	100	3	3
C1693	2HK*6500506B	20.8	27.1	29.0	30	30	10	10
	2HK*6500806B	31.3	39.1	42.1	40	45	8	8
	2HK*6501006B	41.7	51.0	55.1	60	60	6	6
	2HK16501506B	62.5	74.8	81.1	80	90	4	3
	2HK16502006B	83.3	98.7	107.2	100	110	3	2
D2093	2HK*6500806B	31.3	43.5	46.2	45	50	8	8
	2HK*6501006B	41.7	55.5	59.2	60	60	6	6
	2HK16501506B	62.5	79.3	85.3	80	90	4	3
	2HK16502006B	83.3	103.2	111.3	110	125	2	1
	2HK16502506B	104.2	127.1	137.3	150	150	1/0	1/0
	2HK16503006A	125.0	151.9	163.4	175	175	2/0	2/0

* 2HK0 = No Breaker - 2HK1 = Breaker

²O.C.P. = Over-Current Protection**Table 11:** ELECTRICAL DATA (FOR SINGLE SOURCE POWER SUPPLY) - COPPER WIRE 220/240-3-50

N1AH MODEL	HEATER MODEL*	FIELD WIRING						
		MIN. CIRCUIT AMPACITY			MAX. O.C.P. ² AMPS/TYPE		WIRE SIZE - AWG 75°C	
		220V	240V	220V	240V	220V	240V	
B1293	2HK06501025B	44.1	47.6	45	50	8	8	
	2HK06501525B	44.1	47.6	45	50	8	8	
	2HK06501825B	48.8	52.7	50	60	8	6	
C1693	2HK06501025B	44.2	47.7	45	50	8	8	
	2HK06501525B	44.2	47.7	45	50	8	8	
	2HK06501825B	49.0	52.9	50	60	8	6	
D2093	2HK06501025B	48.2	51.4	50	60	8	6	
	2HK06501525B	48.2	51.4	60	60	8	6	
	2HK06501825B	51.2	56.2	60	60	6	6	

* 2HK0 = No Breaker - 2HK1 = Breaker

²O.C.P. = Over-Current Protection**NOTE:** 30 KW 3 Ø not approved for single source power supply.

Table 12: ELECTRICAL DATA (FOR MULTI-SOURCE POWER SUPPLY) - COPPER WIRE 208/230-1-60¹

N1AH MODEL	HEATER MODEL	MIN. CIRCUIT AMPACITY			MAX. TIME DELAY FUSE			75°C WIRE SIZE - AWG		
		CIRCUIT			CIRCUIT			CIRCUIT		
		1ST	2ND	3RD	1ST	2ND	3RD	1ST	2ND	3RD
		208/240V	208/240V	208/240V	208/240V	208/240V	208/240V	208/240V	208/240V	208/240V
B1206	2HK16501506B	26.8/30.9	45.1/52.1	-	30/30	50/60	-	10/10	8/6	-
	2HK16501806B	26.8/29.5	28.2/32.8	28.2/32.8	30/30	30/35	30/35	10/10	10/8	10/8
	2HK16501906B	38.3/42.6	45.7/52.6	-	40/45	50/60	-	8/8	8/6	-
C1606	2HK16501506B	27.6/30.2	45.1/52.1	-	30/35	50/60	-	10/8	8/6	-
	2HK16502006B	49.8/56.2	45.1/52.1	-	50/60	50/60	-	8/6	8/6	-
D1406	2HK16501506B	26.6/29.3	45.1/52.1	-	30/30	50/60	-	10/10	8/6	-
D2006	2HK16501506B	29.0/31.3	45.1/52.1	-	30/35	50/60	-	10/8	8/6	-
	2HK16502006B	51.2/57.3	45.1/52.1	-	60/60	50/60	-	6/6	8/6	-
	2HK16502506B	29.0/31.3	45.1/52.1	45.1/52.1	30/35	50/60	50/60	10/8	8/6	8/6
	2HK16503006A	51.2/57.3	45.1/52.1	45.1/52.1	60/60	50/60	50/60	6/6	8/6	8/6

1. Heat amps shown at 240V represents maximum heater rating.

Table 13: ELECTRICAL DATA (FOR MULTI-SOURCE POWER SUPPLY) - COPPER WIRE 208/230-3-60¹

N1AH MODEL	HEATER MODEL	MIN. CIRCUIT AMPACITY			MAX. TIME DELAY FUSE			75°C WIRE SIZE - AWG		
		CIRCUIT			CIRCUIT			CIRCUIT		
		1ST	2ND	3RD	1ST	2ND	3RD	1ST	2ND	3RD
		208/240V	208/240V	208/240V	208/240V	208/240V	208/240V	208/240V	208/240V	208/240V
D2006	2HK16503025A	44.5/49.7	39.1/45.1	-	45/50	40/50	-	8/8	8/8	-

1. Heat amps shown at 240V represents maximum heater rating.

Table 14: ELECTRICAL DATA (FOR MULTI-SOURCE POWER SUPPLY) - COPPER WIRE 220/240-1-50

N1AH MODEL	HEATER MODEL	MIN. CIRCUIT AMPACITY			MAX. TIME DELAY FUSE			75°C WIRE SIZE - AWG		
		CIRCUIT			CIRCUIT			CIRCUIT		
		1ST	2ND	3RD	1ST	2ND	3RD	1ST	2ND	3RD
		220/240V	220/240V	220/240V	220/240V	220/240V	220/240V	220/240V	220/240V	220/240V
B1293	2HK16501506B	27.0/28.9	47.7/52.1	-	30/30	50/60	-	10/10	8/6	-
	2HK16501806B	27.0/28.9	30.1/32.8	30.1/32.8	30/30	35/35	35/35	10/10	8/8	8/8
	2HK16501906B	38.9/41.9	48.3/52.6	-	40/45	50/60	-	8/8	8/6	-
C1693	2HK16501506B	27.1/29.0	47.7/52.1	-	30/30	50/60	-	10/10	8/6	-
	2HK16502006B	51.0/55.1	47.7/52.1	-	60/60	50/60	-	6/6	8/6	-
D2093	2HK16501506B	31.6/33.2	47.7/52.1	-	35/35	50/60	-	8/8	8/6	-
	2HK16502006B	55.5/59.2	47.7/52.1	-	60/60	50/60	-	6/6	8/6	-
	2HK16502506B	31.6/33.2	47.7/52.1	47.7/52.1	35/35	50/60	50/60	8/8	8/6	8/6
	2HK16503006A	55.5/59.2	47.7/52.1	47.7/52.1	60/60	50/60	50/60	6/6	8/6	8/6

Table 15: ELECTRICAL DATA (FOR MULTI-SOURCE POWER SUPPLY) - COPPER WIRE 220/240-3-50

N1AH MODEL	HEATER MODEL	MIN. CIRCUIT AMPACITY			MAX. TIME DELAY FUSE			75°C WIRE SIZE - AWG		
		CIRCUIT			CIRCUIT			CIRCUIT		
		1ST	2ND	3RD	1ST	2ND	3RD	1ST	2ND	3RD
		220/240V	220/240V	220/240V	220/240V	220/240V	220/240V	220/240V	220/240V	220/240V
D2093	2HK16503025A	48.2/51.4	41.3/45.1	-	50/60	45/50	-	8/6	8/8	-

Table 16: AIR FLOW DATA¹

N1AH MODEL	G2FD MODEL	BLOWER MOTOR SPEED	230, 460 VOLT - 60 HZ & 240 VOLT - 50 HZ					208 VOLT - 60 HZ & 220 VOLT - 50 HZ				
			CFM @ EXTERNAL STATIC PRESSURE - IWG									
			0.10	0.20	0.30	0.40	0.50	0.10	0.20	0.30	0.40	0.50
B08	024S(H)17	High	910	875	830	800	745	820	790	745	720	670
		Med.	775	750	720	680	645	700	675	650	610	580
		Low	625	605	580	550	520	565	545	520	495	470
	030S(H)17	High	920	890	850	825	775	830	800	765	745	700
		Med.	785	760	735	700	670	705	685	660	630	605
		Low	630	615	590	565	540	565	555	530	510	485
	036S(H)17	High	930	905	870	850	810	835	815	785	765	730
		Med.	790	775	750	720	695	710	700	675	650	625
		Low	640	625	605	585	560	575	565	545	525	505
	046S(H)17	High	935	910	880	860	820	840	820	790	775	740
		Med.	795	775	760	730	705	715	700	685	655	635
		Low	640	625	610	590	570	575	565	550	530	515
B12	030S(H)17	High	1300	1230	1160	1090	1020	1170	1105	1045	980	920
		Med.	1190	1135	1070	1010	935	1070	1020	965	910	840
		Low	1055	1005	955	905	845	950	905	860	815	760
	036S(H)17	High	1400	1330	1260	1190	1120	1260	1195	1135	1070	1010
		Med.	1285	1230	1165	1105	1030	1155	1105	1050	995	925
		Low	1130	1080	1030	980	920	1015	970	925	880	830
	046S(H)17	High	1415	1400	1360	1320	1280	1275	1260	1225	1190	1150
		Med.	1315	1285	1245	1210	1170	1185	1155	1120	1090	1055
		Low	1140	1110	1080	1050	1015	1025	1000	970	945	915
C16	042S(H)21	High	1645	1590	1535	1470	1405	1480	1430	1380	1325	1265
		Med.	1510	1485	1410	1350	1295	1360	1335	1270	1215	1165
		Low	1385	1350	1310	1275	1225	1245	1215	1180	1150	1105
	048S(H)21	High	1765	1710	1655	1590	1525	1590	1540	1490	1430	1375
		Med.	1615	1590	1515	1455	1400	1455	1430	1365	1310	1260
		Low	1430	1395	1355	1320	1270	1285	1255	1220	1190	1145
D14	048S(H)24	High	1540	1485	1425	1357	1283	1385	1335	1285	1220	1155
		Med-high	1343	1293	1196	1187	1123	1210	1165	1075	1070	1010
		Med-low	1160	1128	1086	1045	981	1045	1015	980	940	885
		Low	985	958	921	880	830	885	860	830	790	745
	060S(H)24	High	1680	1620	1555	1480	1400	1510	1460	1400	1330	1260
		Med-high	1465	1410	1305	1295	1225	1320	1270	1175	1165	1105
		Med-low	1265	1230	1185	1140	1070	1140	1105	1065	1025	965
		Low	1075	1045	1005	960	905	970	940	905	865	815
	061H24	High	1815	1750	1680	1599	1512	1635	1575	1510	1440	1360
		Med-high	1582	1523	1410	1399	1323	1425	1370	1270	1260	1190
		Med-low	1366	1329	1280	1231	1156	1230	1195	1150	1100	1040
		Low	1161	1129	1086	1037	978	1045	1015	975	935	880
D20	060S(H)24	High	2295	2225	2150	2070	2000	2065	2005	1935	1865	1800
		Med	1990	1935	1880	1820	1745	1790	1740	1690	1640	1570
		Low	1695	1655	1615	1570	1505	1525	1490	1455	1415	1355
	061H24	High	2355	2283	2206	2124	2052	2120	2055	1985	1910	1845
		Med	2042	1986	1929	1868	1791	1840	1785	1735	1680	1610
		Low	1739	1698	1657	1611	1544	1565	1530	1490	1450	1390

¹. Includes return air filter, wet coil and largest electric heater.

TABLE 17: ELECTRICAL DATA - COOLING ONLY (50 & 60 HZ)

MODEL N1AH	MINIMUM CIRCUIT AMPACITY				MAXIMUM O.C.P.D.	MINIMUM WIRE SIZE A.W.G.
	60 HZ		50 HZ			
	208V	230V	220V	240V		
B08	2.0	1.8	2.9	2.7	15	14
B12	4.2	3.7	3.2	2.9	15	14
C16	4.9	4.3	3.3	3.0	15	14
D14	3.9	3.4	-	-	15	14
D20	6.4	5.5	7.8	7.2	15	14

TROUBLESHOOTING GUIDE

PROBLEM	POSSIBLE CAUSE
Blower Runs all of the time	1. No heat units do not have 6-pin connector installed.
	2. Limit open or not connected.
	3. Variable speed break-out tab broken out.
	4. Blower OFF delay (approx. 1 min.).
	5. Thermostat fan switch in "ON" position.
Blown Fuse	1. Low voltage short to C or ground from R, Y, G, W, or O.
No 24V	1. 4-pin connector loose.
	2. Loose wire from control to transformer (24V and 230V).
	3. Blown fuse on control board.
No 2nd stage heat	1. Check 6-pin connector and connections to panel mount relays.
	2. Verify that both W1 & W2 are connected at the terminal strip.
No Heat or Limited Heating	1. Check filter.
	2. Closed registers.
	3. Restricted airflow (supply registers or return registers)
	4. Check blower motor operation.
	5. If the safety limit opens 4 times, the control will not permit the heating element to operate for 1 hour.

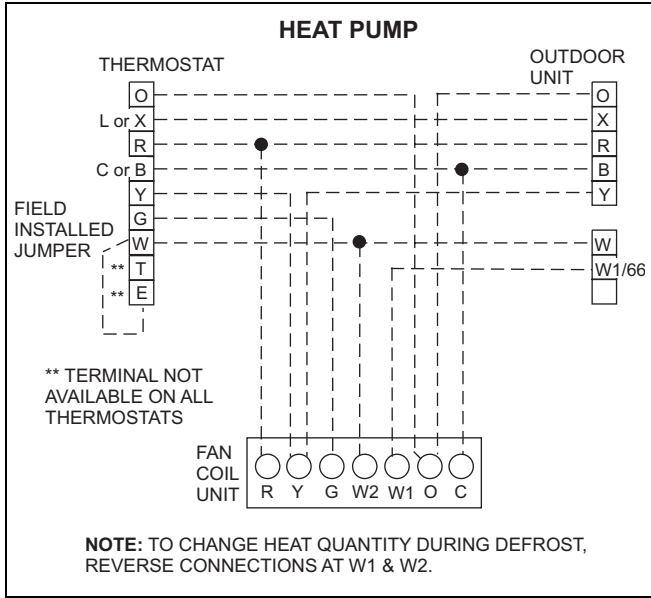

FIGURE 11 : Heat Pump Wiring

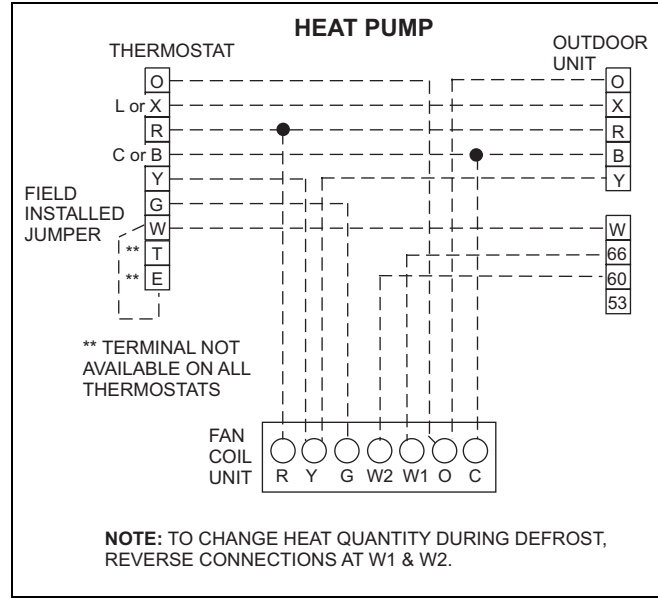

FIGURE 12 : Heat Pump Wiring - Demand Defrost Only

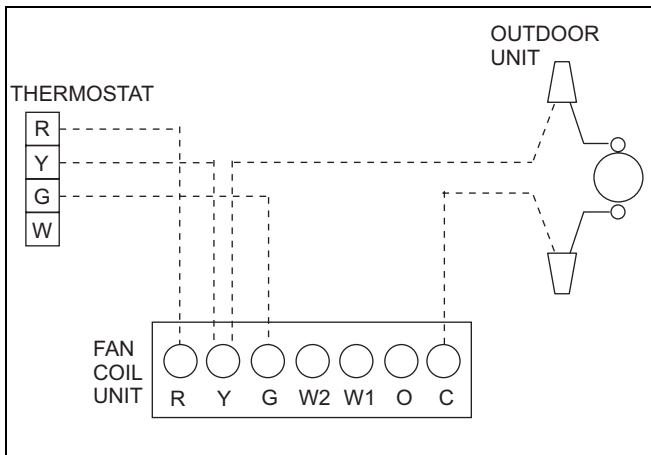

FIGURE 13 : Cooling Wiring

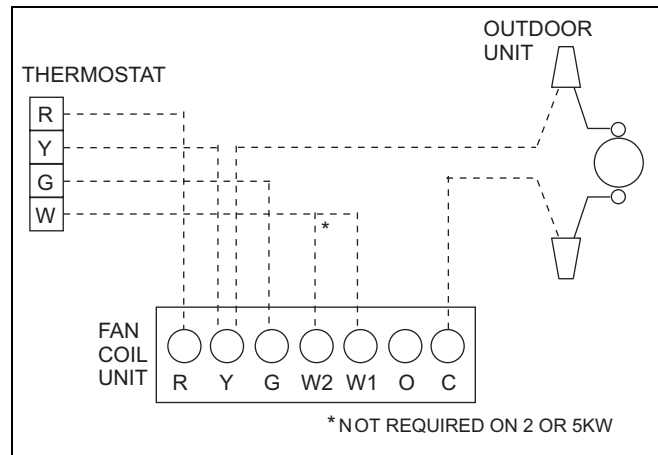

FIGURE 14 : Cooling Wiring with Electric Heat