

INSTALLATION, OPERATION AND MAINTENANCE INSTRUCTIONS
MULTIPOISE
OIL-FIRED
WARM AIR FURNACES

ISSUE 9329
 SAVE THESE INSTRUCTIONS FOR FUTURE REFERENCE

AFFIX LABEL HERE

FOR YOUR SAFETY

DO NOT STORE OR USE GASOLINE OR OTHER FLAMMABLE VAPORS AND LIQUIDS IN THE VICINITY OF THIS OR ANY OTHER APPLIANCE.

DO NOT ATTEMPT TO START THE BURNER WHEN EXCESS OIL HAS ACCUMULATED, WHEN THE FURNACE IS FULL OF VAPOR OR WHEN THE COMBUSTION CHAMBER IS VERY HOT.

WARNING

For use with grade 2 Fuel Oil maximum. Do Not use Gasoline, Crankcase Oil or any Oil containing Gasoline!

CAUTION

Never burn garbage or paper in the heating system and never leave rags or paper around the unit.

CAUTION

These instructions are intended to be used by qualified personnel who have been trained in installing this type of furnace. Installation of this furnace by an unqualified person may lead to equipment damage and/or a hazardous condition which may lead to bodily harm.

GENERAL

This furnace is a true multipoise unit, in that it may be operated in all four positions, i.e., upflow, counterflow (downflow), and horizontal (both left-to-right and right-to-left air flow). Very few modifications are required to change the furnace from one position to another at the job site. The furnace is shipped in the upflow configuration--instructions on changing to other configurations are on page 6 of this document.

It is shipped as a packaged unit, complete with burner and controls. It requires a line voltage (115VAC) connection to the control box, a thermostat hook-up as shown on the wiring diagram, oil line connection(s), adequate ductwork, and connection to a properly sized vent.

The air handling capacity of this furnace is designed for cooling air flow. Refer to Figure 4 for the expected airflows at various external duct static pressures.

IMPORTANT: All local and national code requirements governing the installation of oil burning equipment, wiring and flue connections must be followed. Some of the codes (issued by the Canadian Standards Association, the National Fire Protection Agency, and/or the American National Standards Institute) that may be applicable are:

CSA B139	INSTALLATION CODE FOR OIL BURNING EQUIPMENT
ANSI/NFPA 31	INSTALLATION OF OIL BURNING EQUIPMENT
ANSI/NFPA 90B	WARM AIR HEATING AND AIR CONDITIONING SYSTEMS
ANSI/NFPA 211	CHIMNEYS, FIREPLACES, VENTS AND SOLID FUEL BURNING APPLIANCES
ANSI/NFPA 70	NATIONAL ELECTRICAL CODE
CSA C22.1	CANADIAN ELECTRICAL CODE

Only the latest issues of the above codes should be used, and are available from either:

The National Fire Protection Agency
Batterymarch Park
Quincy, MA 02269

or The Canadian Standards Association
178 Rexdale Blvd.
Rexdale, Ontario M9W 1R3

LOCATION

WARNING

This furnace is not watertight and is not designed for outdoor installation. This furnace shall be installed in such a manner as to protect the electrical components from water. Outdoor installation would lead to a hazardous electrical condition and to premature furnace failure.

CAUTION

For an attic installation it is important to keep insulation 12" or more away from any furnace openings. Some types of insulating materials may be combustible.

This furnace is approved for reduced clearances to combustible construction, therefore, it may be installed in a closet or similar enclosure. It is also approved for attic

installation. As this unit may be installed as an upflow, counterflow, or horizontal furnace, it may be located in a basement, on the same level as the area to be heated, suspended, or in a crawlspace. In any case, the unit should always be installed level.

In a basement, or when installed on the floor (as in a crawlspace), it is recommended that the unit be installed on a concrete pad that is 1" to 2" thick.

When installed in the counterflow position, this furnace **must not** be installed on combustible flooring, unless the approved sub-base is used. Also, since the flue pipe extends upward along the side of the cabinet in the counterflow position, care must be taken to insure that the clearances from the flue pipe to combustible construction are maintained.

When installed in a horizontal position, the furnace may be suspended by using an angle iron frame, as long as the total weight of both the furnace and the frame are allowed for in the support calculations. (Other methods of suspending are acceptable.)

The required minimum clearances for this furnace in all positions are specified in Figure 3.

The furnace should be located as close as possible to the chimney or vent in order to keep vent connections short and direct. The furnace should also be located as near as possible to the center of the air distribution system.

Air for Combustion and Ventilation:

This furnace should be installed in a location in which the facilities for ventilation permit satisfactory combustion of oil, proper venting and the maintenance of ambient temperature at safe limits under normal conditions of use. The location should not interfere with proper circulation of air within the confined space.

In addition to air needed for combustion, process air shall be provided as required for: cooling of equipment or material, controlling dew point, heating, drying, oxidation or dilution, safety exhaust and odor control.

In addition to air needed for combustion, air shall be supplied for ventilation, including all air required for comfort and proper working conditions for personnel.

The barometric draft regulator, included with the furnace, shall be installed in the same room or enclosure as the furnace in such a manner as to prevent any difference in pressure between the regulator and the combustion air supply.

Air requirements for the operation of exhaust fans, kitchen ventilation systems, clothes dryers, and fireplaces shall be considered in determining the adequacy of a space to provide combustion air requirements.

In unconfined spaces in buildings of conventional frame, brick or stone construction infiltration may be adequate to provide air for combustion, ventilation and dilution of flue gases. This determination must be made on an individual installation basis and must take into consideration the overall volume of the unconfined space, the number of windows and ventilation openings, the number of doors to the outside, internal doors which can close off the unconfined space and the overall tightness of the building construction.

Many new buildings and homes (and older ones that have been weatherized) must be considered as being tight construction and, therefore, infiltration will not be sufficient to supply the necessary air for combustion and ventilation.

A building can be considered as being of tight construction when:

- a. Walls and ceilings exposed to the outside atmosphere have a continuous water vapor retarder with a rating of one perm or less with openings gasketed or sealed and /or
- b. Weatherstripping has been added on operable windows and doors, and/or
- c. Caulking or sealants are applied to areas such as joints around window and door frames, between sole plates and floors, between wall-ceiling joints, between wall panels, at penetrations for plumbing, electrical and fuel lines and at other openings.

If combustion and ventilation air must be supplied to an unconfined space from outside, an opening with a free area of not less than one square inch per 1,000 BTU per hour of total input of all appliances within the unconfined space (but not less than 100 square inches) must be provided. This opening must be located such that it can not be blocked at any time.

When this furnace is installed in a closet or enclosure, two (2) ventilation openings, with **OPEN AREA** as dimensioned in Fig. 1, are required for combustion air. The openings should be located about 6" from the top and the bottom of the enclosure at the front of the furnace.

BONNET CAPACITY 1,000 BTU/HR.	LENGTH INCHES	HEIGHT INCHES
55	18	9
85	18	9
100	20	10
125	20	10

Fig. 1

For a confined space, where air is taken from an interior space, two permanent openings of equal area are required. One opening must be within 12" of the ceiling and the other within 12" of the floor. Each opening must have a free area of at least 1 sq. inch per 1,000 BTU of total input rating but no less than 100 sq. inches.

If outside air is supplied to a confined space, then the two openings must be equal and located as above and the free area of each must be:

- 1. 1 sq. inch per 4,000 BTU of total rating when the air is directly communicated from the outdoors.
- 2. 1 sq. inch per 4,000 BTU of total input rating when the air is brought in through vertical ducts.
- 3. 1 sq. inch per 2,000 BTU of total input rating when the air is transferred through horizontal ducts.

When ducts are used to supply air, they must be of the same cross sectional area as the free area of the openings to which they connect.

The minimum dimension of rectangular air ducts must not be less than 3 inches.

In calculating free area, consideration shall be given to the blocking effect of louvers, grilles or screens protecting openings. Screens used shall not be smaller than 1/4 inch mesh and shall be readily accessible for cleaning. If the free area through a design of louvered or grille is known, it shall be used in calculating the size design and free area specified. If the design and free area is not known, it may be assumed that wood louvers will have 20 percent free area and metal louvers and grilles will have 60 percent free area. Louvers shall be fixed in the open position or interlocked with the furnace so they are opened automatically at furnace start-up and remain open during furnace operation.

WARNING

Do Not block the combustion air openings in the furnace. Any blockage will result in improper combustion and may result in a fire hazard and/or cause bodily harm.

Ductwork Recommendations:

The proper sizing of warm air ducts is necessary to insure satisfactory furnace operation. Ductwork should be in accordance with the latest editions of NFPA-90A (Installation of Air Conditioning and Ventilating Systems) and NFPA-90B (Warm Air Heating and Air Conditioning Systems) or Canadian equivalent.

The supply ductwork should be attached to the flanged opening provided at the discharge end of the furnace. See Fig. 5 for the dimensions of this opening.

Knockouts are provided on both sides of the furnace to facilitate the side panel cut out required to assemble the return ductwork. This can be done on either the right or the left side of the furnace. See Fig. 5 for location and dimensions. Undersized cut-outs will adversely affect the airflow capability of the furnace.

NOTE: THE BACK SHOULD NOT BE CUT OUT FOR RETURN AIR!

When the provided external filter rack is used, the return air duct should be attached as per Fig. 6.

Provision is also made on this furnace for a bottom return air duct. (We recommend the use of this opening for horizontal and counterflow installations.) The specifications for this opening are also illustrated in Fig. 5. If the bottom return is not used, a field-supplied galvanized steel filler plate should be used to block off the opening.

The following recommendations should be followed when installing the ductwork:

1. Install locking type dampers in all branches of the individual ducts to balance out the system. Dampers should be adjusted to impose the proper static at the outlet of the furnace.
2. A flexible duct connector of noncombustible material should be installed at the unit on both the supply and return air system. In applications where extremely quiet operation is necessary, the first 10 feet (if possible) of supply and return ducts should be internally lined with acoustical material.
3. In cases where the return air grille is located close to the fan inlet, there should be at least one 90° air turn between fan inlet and grille. Further reduction in sound level can be accomplished by installing acoustical air turning vanes or lining duct as described in item 2 above.
4. When a single air grille is used, the duct between grille and furnace must be the same size as return opening in furnace.

CAUTION

Return air grilles and warm air registers must not be obstructed.

WARNING

When supply ducts carry air circulated by the furnace to areas outside the spaces containing the furnace, the return air shall also be handled by a duct sealed to the furnace casing and terminating outside the space containing the furnace. Incorrect ductwork termination and sealing will create a hazardous condition which could lead to bodily harm.

When installing the furnace with cooling equipment for year round operation, the following recommendations must be followed for series or parallel air flow:

1. In series air flow applications, the coil is mounted after the furnace in an enclosure in the supply air stream. The furnace blower is used for both heating and cooling air flow.

WARNING

The coil **MUST** be installed on the air discharge side of the furnace. Under no circumstances should the air flow be such that cooled, conditioned air can pass over the furnace heat exchanger. This will cause condensation in the heat exchanger and possible failure of the heat exchanger which could lead to a fire hazard and/or a hazardous condition which may lead to bodily harm. Heat exchanger failure due to improper installation may not be covered by warranty.

2. In parallel flow installation, dampers must be provided to direct air over the furnace heat exchanger when heat is desired and over the cooling coil when cooling is desired.

IMPORTANT: The dampers should be adequate to prevent cooled air from entering the furnace, and if manually operated, must be equipped with the means to prevent operation of either the cooling unit or furnace unless the damper is in the full cool or heat position.

Venting Instructions:

Venting of the furnace should be to the outside and in accordance with local codes or requirements of the local utility.

OIL FIRED APPLIANCES SHALL BE CONNECTED TO FLUES HAVING SUFFICIENT DRAFT AT ALL TIMES TO ENSURE SAFE AND PROPER OPERATION OF APPLIANCE.

For additional venting information refer to ANSI/NFPA 211 Chimney, Fireplaces, Vents and Solid Fuel Burning Appliances and/or CSA B139 Installation Code.

This furnace is certified for use with Type "L" vent (maximum flue gas temperature 575°F).

The flue elbow shipped with the furnace should be attached with screws to the outlet of the heat exchanger. It is a special short radius elbow (that, also, reduces to 5" diameter for the 55,85, and 100 size furnaces).

If the furnace is to be installed as an upflow, the flue pipe clearance knockout in the top panel should be removed. Install the flue elbow so that it exits the furnace cabinet through that opening. (For Horizontal or counterflow installation, one of the side panel knockouts will be used. See page 6.)

Pre-Installation Vent System Inspection:

Before this furnace is installed, it is highly recommended that any existing vent system be completely inspected.

For any chimney or vent, this should include the following:

1. Inspection for any deterioration in the chimney or vent. If deterioration is discovered, the chimney must be repaired or the vent must be replaced.
2. Inspection to ascertain that the vent system is clear and free of obstructions. Any blockage must be cleared before installing this furnace.
3. Cleaning the chimney or vent if previously used for venting a solid fuel burning appliance or fireplace.
4. Confirming that all unused chimney or vent connections are properly sealed.
5. Verification that the chimney is properly lined and sized per the applicable codes. (Refer to list of codes on page 2.)

Masonry Chimney:

This furnace can be vented into an existing masonry chimney. This furnace must not be vented into a chimney servicing a solid fuel burning appliance. Before venting this furnace into a chimney, the chimney must be checked for deterioration and repaired if necessary. The chimney must be properly lined and sized per local or national codes.

If the furnace is vented into a common chimney, the chimney must be of sufficient area to accommodate the total flue products of all appliances vented into the chimney.

The following requirements are provided for a safe venting system:

1. Be sure that the chimney flue is clear of any dirt or debris.
2. Be sure that the chimney is not servicing an open fireplace.
3. Never reduce the pipe size below the outlet size of the factory supplied flue elbow.
4. All pipe should be supported using the proper clamps and/or straps. These supports should be at least every four (4) feet.
5. All horizontal runs of pipe should have at least a 1/4" per foot of upward slope.
6. All runs of pipe should be as short as possible with as few turns as possible.
7. Seams should be tightly joined and checked for leaks.
8. The flue pipe must not extend into the chimney but be flush with the inside wall.
9. The chimney must extend three (3) feet above the highest point where it passes through a roof of a building and at least two (2) feet higher than any portion of a building within a horizontal distance of ten (10) feet. It shall also be extended at least five (5) feet above the highest connected equipment flue collar.
10. Check local codes for any variance.

Factory Built Chimneys:

May use listed factory built chimneys. Refer to chimney manufacturers instructions for proper installation.

Horizontal Venting:

This furnace may be horizontally vented through an outside wall when installed with the following auxiliary inducer blower:

available from: Tjernlund Products, Inc. Model SS1C

Tjernlund Products, Inc.
1601 Ninth Street
White Bear Lake, MN 55110-6795

NOTE: An isolation relay should be used to allow proper operation of the ignition control with the auxiliary blower. Instructions for connecting the relay are included in the Tjernlund blower.

CAUTION

USE METALLIC VENT PIPE, ONLY! PLASTIC VENTING MATERIALS ARE PROHIBITED!

Oil Burner:

This furnace is supplied with a high pressure atomizing retention head type burner (for use with not heavier than grade 2 Fuel Oil). The air tube length, from the face of the mounting plate to the extreme face of the end cone, should be as follows:

<u>Capacity</u>	<u>Length</u>
55,000	5"
85,000	5"
100,000	5"
125,000	7"

Lubricate the burner motor with SAE 10 oil. Once each year, pour two (2) teaspoons of oil slowly into each oil cup.

Oil Connections:

Complete instructions for installation of the fuel oil piping will be found in the oil burner installation instructions included with the furnace.

Oil line entry holes are produced in the side panels and top panel. Two holes are provided in each location, so that a two-pipe system may be used if desired.

An oil filter should be used with all oil burners, installed as close as possible to the burner.

Barometric Draft Control:

The barometric draft control shipped with the furnace must be used with the furnace to insure proper operation. Instructions for installing the control are packed with the control.

Electrical:

The appliance must be installed in accordance with current ANSI/NFPA 70 National Electrical Code, CSA

C22.1 Canadian Electrical Code Part 1 and/or local codes.

The control system depends on the correct polarity of the power supply. Connect "HOT" wire (H) and "NEUTRAL" wire (N) as shown in Fig. 7.

A separate line voltage supply should be used with a fused disconnect switch or circuit breaker between the main power panel and the unit. See Fig. 7.

WARNING

The unit cabinet must have an uninterrupted or unbroken electrical ground to minimize personal injury if an electrical fault should occur. A green ground screw is provided in the control box for this connection.

Use copper wire only for 115V supply service to unit.

Metallic conduit (where required/used) may terminate at the side panel of the unit. It is not necessary to extend the conduit inside the unit from the side panel to the control box.

When replacing any original furnace wiring, use only 105 degree C, 16 AWG copper wire.

Instructions for wiring the thermostat are packed in the thermostat (field supplied) box. Make the thermostat connections as shown in Fig. 7 at the 24 volt terminal board on the primary relay.

When installing optional accessories to this appliance, follow the manufacturer's installation instructions included with the accessory. Other than wiring for the thermostat, wire with a minimum of type "T" insulation (63°F rise) must be used for accessories.

Filters:

An external filter rack is provided as standard equipment with this furnace. The assembly and installation of this filter rack is shown in Fig. 6.

To Change from Upflow to Horizontal or Downflow:

- Remove the burner from the unit by removing the three burner mounting nuts. Prevent putting undue strain on burner wiring. (It may be necessary to disconnect the burner wiring in some cases.)

- Note that the three burner mounting studs are in the "nine, twelve, and three" o'clock positions on the burner mounting plate.
- **In addition, for horizontal installation,** determine which "side" will become the "top", when the unit is laid down. Remove the flue pipe clearance knock-out from the top front of that side panel. Install the flue elbow so that it exits the cabinet of the furnace through that opening.
- **In addition, for counterflow installation,** the flue pipe must exit the cabinet through one of the side panel openings (as above), then extended up the side of the furnace. **Insure that adequate clearances to combustibles are observed!!** (It may be necessary to install a sheet-metal shield on any adjacent wall to insure that a fire hazard condition does not exist.) Before turning the furnace upside down remove the two screws (on the top of the unit) that fasten the top panel to the intermediate panel. (This will allow for removal of the intermediate panel when cleaning or removing the heat exchanger.)
- Place the furnace in the installation position (i.e., on its side). Remove the burner mounting stud that is now in the six o'clock position (See illustrations A & B). Reinstall the stud in the other open position on the mounting plate, so that once again there are studs in the nine, twelve, and three o'clock positions. It may be necessary to use two of the burner mounting nuts as "Jam Nuts" on the stud in order to provide a means of using a wrench to remove a tight stud.
- Reinstall the burner, insuring that all three burner mounting nuts are tight. **IMPORTANT:** Burner must always be installed in the upright position with the ignition control on top. In the counter flow position, it is recommended that the burner be pushed "UP" as far as possible on the studs and the nuts tightened while the burner is being held "UP".

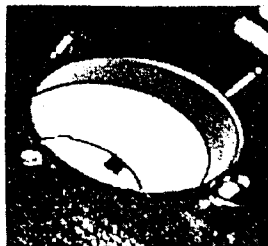

Illustrations A & B

WARNING

Do not use this furnace as a construction heater. Use of this furnace as a construction heater exposes the furnace to abnormal conditions, contaminated combustion air and the lack of air filters. Failure to follow this warning can lead to premature furnace failure and/or vent failure which could result in a fire hazard and/or bodily harm.

WARNING

Installation of this furnace in an area where it will receive contaminated combustion air must be avoided. Such contamination would include the following: ammonia, chlorine, hydrogen sulfide, halogenated hydrocarbons, carbon tetrachloride, cleaning solvents, hydrochloric acid, water softening chemicals and other similar chemicals. Failure to follow this warning will lead to premature rusting of the heat exchanger and possible premature furnace failure and/or vent failure which could result in a fire hazard and/or bodily harm.

Operational Checkout:

DO NOT START THE BURNER UNLESS THE BLOWER ACCESS DOOR IS SECURED IN PLACE.

The installation of the furnace is now complete and the operational checkout may be performed.

START-UP:

1. Check the wiring against the diagram in Fig. 7.
2. Open the valve on the oil supply line.
3. Reset the primary control.
4. Set the thermostat above room temperature.
5. Set the main electrical switch to "ON" position and the burner should start.

DO NOT TAMPER WITH THE UNIT OR CONTROLS - CALL YOUR SERVICEMAN.

Recommended Installation Practices and Combustion Check:

In order to obtain the optimum performance from the oil burner, the following set-up procedures must be followed:

1. A test kit (Bacharach No. 5022 kit or equivalent) to measure the smoke, stack draft, over-fire draft, CO₂, and stack temperatures must be used in order to obtain the proper air band setting. Although all of the above measurements are required for optimum set up and efficiency data, the most important readings that must be taken are the smoke number, over the fire draft and stack draft.
2. The proper smoke number has been established by engineering tests to be between 0 & 1. This degree of smoke emission is commonly referred to as a "Trace" of smoke. It is recommended to use a Bacharach true spot smoke test set or equivalent.
3. In order to ensure the proper draft through the furnace, a barometric draft regulator, which is supplied with the furnace, must be installed as close to the breech of the furnace as possible. In order for this device to function properly, the barometric damper must be mounted with the hinge pins horizontal and the face of the damper vertical (see instructions included with damper). The draft regulator should be adjusted after the furnace has been firing for at least five minutes and the stack draft should be measured and set between $-.025''$ wc and $-.035''$ wc. The draft should be checked with a Bacharach MZF draft gauge or equivalent.
4. The over the fire draft, which is taken through the hole that is provided in the observation door, is a measurement that is necessary to determine if there is a blockage between the oil burner and the flue outlet. There should be between a $.005''$ wc to $.015''$ wc pressure drop through the furnace. This would set the range of the over the fire draft between $-.01''$ wc to $-.03''$ wc. A reading above $-.01''$ wc, for example $+0.1''$ wc, would indicate that the furnace is in an extremely high pressure condition in the primary section. This condition may be caused by excessive combustion air due to the air band being too wide open or a lack of flue draft (chimney effect) or some other blockage, such as soot, in the secondary section of the heat exchanger.

5. The CO₂ and stack temperature instruments will enable you to obtain the data that is required to determine the thermal efficiency of the furnace. Although this information is nice to have, it is not essential in the basic set up of the furnace.
6. An oil filter should be installed as close to the burner as possible with all oil burners and is essential on the lower firing rate burners. We recommend the use of a low pressure drop oil filter such as the General Filter, Inc. model #1A-25A or equivalent. It is critical that the oil capacity be equivalent or greater than the fuel pump gear capacity. For a two pipe system this is 25gph.
7. The oil pressure regulator is factory set to give nozzle oil pressures of 100PSIG. The firing rate noted on the nameplate may be obtained with "standard" nozzles by adjusting the pump pressure as noted on the chart below or noted on the label on the furnace.
NOTE: This appliance is equipped with one of the oil burners as listed on the chart below and rating label on the furnace. Use the nozzle listed for that specific oil burner.
On a new installation the air entrapped in the oil line leading from the tank to the nozzle must be thoroughly purged in order to prevent excessive after drip. The oil pump is provided with a special fitting that will enable you to purge any air between the tank and oil pump. The proper procedure for performing this operation is as follows:
Place a piece of clear plastic 1/4" dia. tubing over the purge fitting on the oil pump. Start the oil burner, then open the purge fitting and allow the burner to run until the purge tube is completely free of air bubbles. At this point tighten the purge fitting which will allow the oil to run to the nozzle and fire the burner. (If the purging takes longer than 15 seconds and no flame has been established the burner will stop. Push the reset button on top of Primary Control to restart burner.) For detailed information on operation of primary control refer to instructions included with furnace.
8. After all the set up procedures mentioned above have been completed, the burner should be allowed to operate and an inspection mirror should be used to observe the flame pattern at the tip of the nozzle. Any irregularities such as burning to one side or pulsating flame patterns should be corrected by changing the nozzle.

BURNER, NOZZLE AND PUMP PRESSURE CHART

HEATING CAPACITY BTU/HR.	FIRING RATE GAL/HR/ (US)	PUMP PRESSURE PSIG	DUCANE OIL BURNER		R.W. BECKETT OIL BURNER	
			MODEL	NOZZLE	MODEL	NOZZLE
55,000	.50	100	DRC-10A	.50GPH 80' SOLID	AFG	.50 GPH 80' SOLID
85,000	.76	103	DRC-10A	.75 GPH 80' SOLID	AFG	.75 GPH 70' HOLLOW
100,000	.90	100	DRC-10A	.90 GPH 80' SOLID	AFG	.90 GPH 70' HOLLOW
125,000	1.12	104	DRC-15A	1.10 GPH 80' SOLID	AFG	1.10 GPH 70' HOLLOW

Fan Adjustment Check:

This furnace is equipped with a 3 speed direct drive motor to deliver a temperature rise within the range specified on the rating plate, between the return and supply plenums, at the external duct static pressure noted on the rating label.

Adjust the fan speed so that the temperature rise is within the rise specified on the rating plate. Consult the wiring diagram for speed changes on the direct drive motor.

To adjust fan OFF time, set the DIP switches on the control board as shown to obtain the desired timing (See Fig. 2).

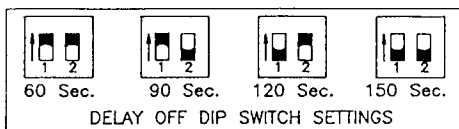

Figure 2

Limit Control Check:

After the furnace has been in operation for at least 15 minutes, restrict the return air supply by blocking the filters or closing the return registers and allow the furnace to shut down on high limit. The burner will shut OFF and the main blower should continue to run.

Remove the restriction and the burner should come back on in a few minutes.

For Year Round Air Conditioning:

The furnace is designed for use in conjunction with cooling equipment to provide year round air conditioning. The blower has been sized for both heating and cooling, however, the fan motor speed may need to be changed to obtain the necessary cooling air flow.

Heating:

The blower speed is factory set to deliver the required air flow at normal duct static pressure.

Cooling:

The blower speed may be adjusted in the field to deliver the required air flow, for cooling application, as outlined in Fig. 4.

Constant Blower Switch:

This furnace is equipped with a constant low speed blower option. Whenever the room thermostat is not calling for heating or cooling, the blower will run on low speed in order to provide air circulation. If this constant blower option is not desired, the rocker switch on the side of the control box may be used to "turn off" the constant speed.

MAINTENANCE

This furnace should never be operated without an air filter. Disposable filters should be replaced at least once a year. If equipped to provide cooling, filters should be replaced a minimum of twice a year.

To avoid personal injury, make sure the electrical supply power is "OFF" before servicing.

ALWAYS KEEP THE MAIN OIL VALVE TURNED OFF, IF THE BURNER IS SHUT DOWN FOR AN EXTENDED PERIOD OF TIME.

WARNING

Before performing any service functions, unless operations specifically require the power to be on, make sure all utilities are turned "OFF" upstream of the appliance. Failure to comply with this warning will cause a fire hazard and/or bodily harm.

Periodic oiling of the blower motor may be necessary. Check for instructions on the inside of your blower compartment door.

To maintain proper performance, the oil burner nozzle must be replaced once a year. Contact your dealer serviceman if you are unsure of this procedure.

The procedure for nozzle installation and/or replacement is outlined in the oil burner instruction manual which came with the furnace. For ease of maintenance, the oiling procedure for the burner motor, as outlined in this manual, should be performed at this time.

After replacement of the nozzle, the burner should be adjusted in accordance with the "**COMBUSTION CHECK**" section of the instruction.

Ordinarily, it is not necessary to clean the heat exchanger or flue pipe every year, but it is necessary to have your oil burner serviceman check the unit before each heating season to determine whether cleaning or replacement of parts is required.

If cleaning is necessary, the following steps should be performed:

1. Turn "**OFF**" all utilities upstream of the furnace.
2. Disconnect the flue pipe and remove the flue elbow.
3. Remove the collar on the flue connection.
4. Remove the observation door.
5. Remove the upper intermediate panel.
6. Remove the flue collector box from the secondary heat exchanger tube flange. This exposes the inside surfaces of the secondary tubes of the heat exchanger. If only the secondary needs to be cleaned, no further disassembly is required.
7. Clean the secondary tubes and flue pipe with a stiff brush and vacuum cleaner.

If the primary heat exchanger section is also to be cleaned:

8. Disconnect the limit control wires
 9. Disconnect the oil line and remove the oil burner from the furnace.
 10. Remove the collar on the observation tube.
 11. Remove the lower intermediate panel. (Care must be taken not to bend or damage the limit control.)
 12. Loosen to hand tightness the three (3) nuts labeled "A" in Figure 5. Remove the screws labeled "B" in Figure 5. Slide the combustion chamber forward, out of the heat exchanger. Be careful not to bump the combustion chamber as it becomes brittle after having been fired.
 13. Again, use a stiff brush and vacuum cleaner to clean the inside of the primary drum.
-

CAUTION

Never use incendiary type cleaners (smoke sticks) for cleaning!!

14. Before reassembly, the heat exchanger and combustion chamber should be inspected to determine if replacement is required. After cleaning, place combustion chamber back into primary drum and secure with the "B" screws--insure that the cover plate gasket is in place before tightening the screws. (Care must be taken not to damage the combustion chamber.)
15. Tighten the "A" nuts to 30 pound-inches of torque (firm, but not overly tight).
16. Replace the collector box on the secondary tube flange, insuring proper placement of the gasket. **If gasket is damaged in any way, it should be replaced!** Tighten the screws to 30 pound-inches of torque.
17. Replace the lower, then upper intermediate panels, flue and observation tube collars, observation door, flue elbow, limit wiring, and oil burner.
18. Reconnect the flue pipe and oil pipe(s).

19. Readjust burner for proper operation. Check limit operation as outlined in this manual.

Blower Removal:

To remove the blower from the furnace:

1. Turn "OFF" all utilities upstream of the furnace.
2. Remove the louvered door and blower door.
3. Remove the blower retaining screw (on the blower partition panel, near the corner where the intermediate panel and blower partition meet).
4. Remove cover from control box and disconnect the thermostat and power wires from the board.
5. Remove the three (3) screws holding control box to the blower partition.
6. Slide the blower forward on the rails toward the front of the unit until the motor wire connections at the terminal block on the motor can be easily reached and disconnected.

7. Disconnect the motor wires at the terminal block on the motor and then disconnect the two (2) red wires connected to the auxiliary limit control mounted on the opposite side of the blower.
8. Swing control box out of the way of the blower and remove blower from unit.

CAUTION

Be sure the blower is adequately supported when sliding out of the mounting rails, especially in the horizontal or counterflow positions, in order to prevent dropping the blower and injuring yourself or damaging the blower!

9. Reverse the above steps to reinstall the blower. (Refer to wiring diagram Fig. 7 of this instructions or the diagram located on the inside of the louvered door to properly rewire the unit.)

MINIMUM CLEARANCE TO COMBUSTIBLES

(Adequate service clearance should be provided over and above these dimensions, as required.)

CLEARANCE FROM :	UPFLOW	COUNTERFLOW	HORIZONTAL
Top of furnace casing or plenum	2"	2"	2"
Top of horizontal warm-air duct within 6 ft of furnace	2"	2"	3"
Flue pipe, measured horizontally or below pipe	4"	4"	4"
Flue pipe, measured vertically above pipe	8"	8"	8"
Any side of supply plenum and warm-air duct within 6 ft of furnace	1"	4***	1"
Front of furnace	8"	8"	24"
Sides of furnace	0"	1"	2"
Rear of furnace	1"	1"	1"
Bottom of furnace	0**	0***	0**

* Floor may be combustible

** Floor shall be non-combustible, except when installed on MP2199 Base No.(20073901 for 55,000 or 85,000 output models; 20073902 for 100,000 or 125,000 output models), floor may be combustible and 4" decreased to 2".

Figure 3

WARNING

When operating the furnace in the heating mode, the static pressure and the temperature rise (supply air temperature minus return air temperature) must be within those limits specified on the rating label. Failure to follow this warning could lead to severe furnace damage.

AIR-FLOW DATA

UNIT OUTPUT (KBTUH)	BLOWER SPEED	EXTERNAL STATIC									
		0.1	0.2	0.3	0.4	0.5	0.6	0.7	0.8	0.9	1.0
55 (10 X 9 WHEEL) (1/3 HP MOTOR)	LOW	825	815	790	760	720	655	600	525	425	290
	MED	1185	1160	1125	1085	1030	965	875	790	660	550
	HIGH	1570	1505	1435	1365	1290	1200	1095	985	865	685
85 (10 X 9 WHEEL) (1/3 HP MOTOR)	LOW	1140	1130	1110	1100	1035	960	875	780	645	490
	MED	1405	1375	1315	1255	1185	1120	1035	920	800	635
	HIGH	1665	1625	1610	1535	1455	1365	1165	1045	925	780
100 (12 X 9 WHEEL) (1/2 HP MOTOR)	LOW	1340	1330	1320	1290	1270	1215	1180	1125	1045	990
	MED	1695	1645	1615	1565	1530	1465	1410	1335	1255	1165
	HIGH	1965	1915	1865	1805	1745	1665	1590	1515	1445	1345
125 (12 X 12 WHEEL) (3/4 HP MOTOR)	LOW	1535	1495	1450	1420	1365	1330	1275	1205	1125	1035
	MED	2000	1965	1890	1795	1755	1690	1625	1555	1480	1375
	HIGH	2240	2170	2085	1980	1935	1820	1750	1665	1590	1510

NOTES:

- 1). AIR FLOW VALUES IN CUBIC FEET PER MINUTE (CFM), ROUNDED TO NEAREST FIVE (5) CFM
- 2). DATA TAKEN WITHOUT FILTERS IN PLACE

Figure 4

GENERAL LAYOUT MULTI-POISE OIL FURNACE

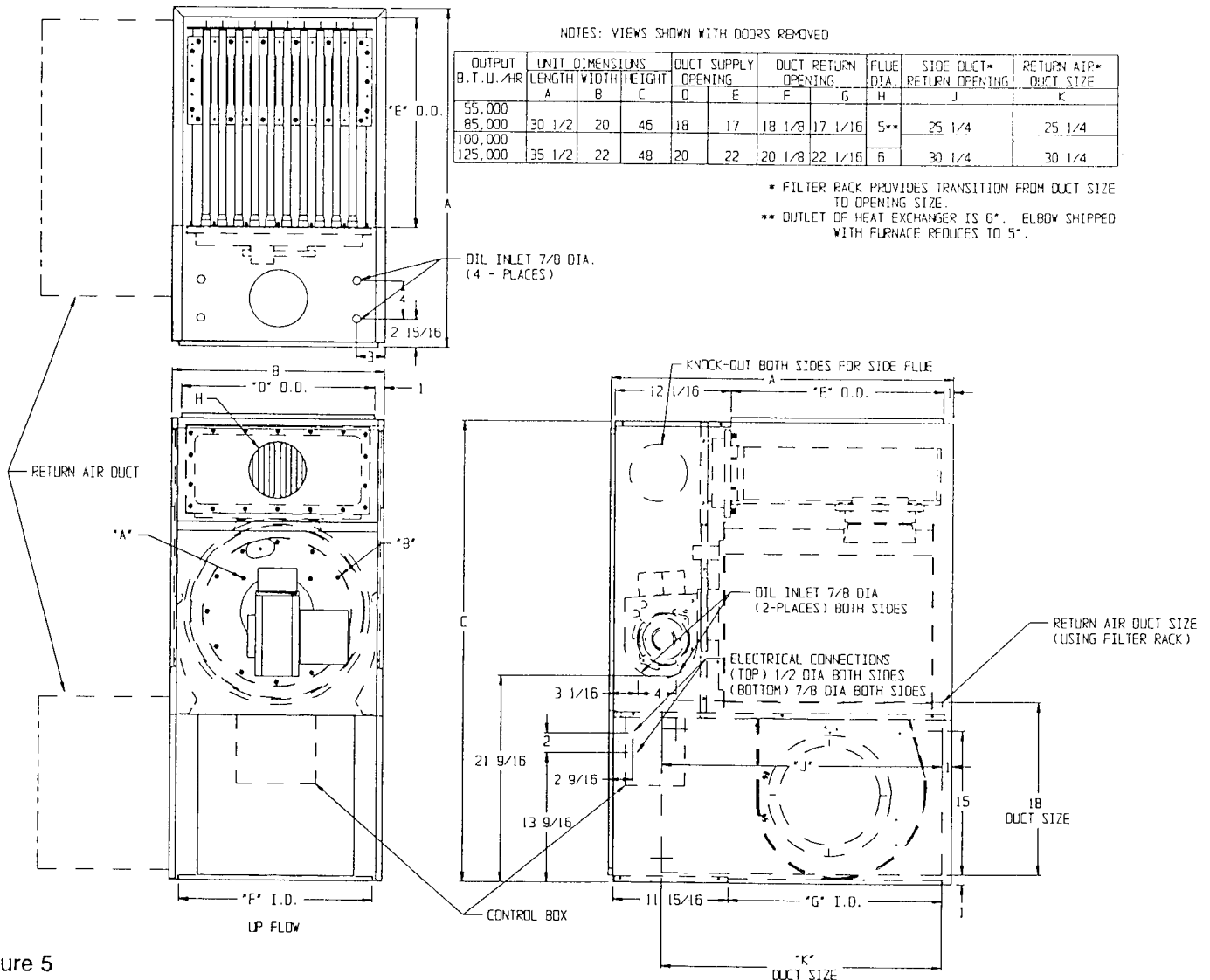

Figure 5

Filters

A filter and filter rack is supplied with the furnace. It is **NECESSARY THAT ALL FURNACES BE EQUIPPED WITH A FILTER.**

When filter rack is used on side of furnace:

1. Filter rack may be mounted on either side of furnace.
2. The filter rack is made up of four (4) pieces - a top and bottom (which are the same), and the rear and access panels (which are the same).
3. Using corner indentations as a guide, cut out the selected side duct return opening (see Fig. 5).
4. Clip the filter rack pieces together, as shown.
5. Remove the rear-most sheet metal screw (approximately 10" from the front of the unit) from the base. Align the second hole from the front of the filter rack bottom piece with the base hole and reinsert the screw. (The frame should be centered over the knockout opening.)

6. Hold the filter rack against the unit (make sure it is square) and drill the remaining holes in the side of the unit located according to the clearance holes in the filter rack top, bottom, and rear panels. **DO NOT SCREW THE ACCESS PANEL IN PLACE!**

7. To fasten return air duct to filter rack, first cut a notch in the return air duct (for filter access panel) to dimension shown in detail. Then slide duct over filter rack.

8. **For 55 and 85 sizes:**

Remove access panel, slide filter in place, then replace access panel.

For 100 and 125 sizes:

Remove metal rod from filter. Trim 2" from width of filter (20" to 18"). Reinsert rod into filter at an angle, so that it does not extend past sides of filter. Remove access panel, slide filter in place, then replace access panel.

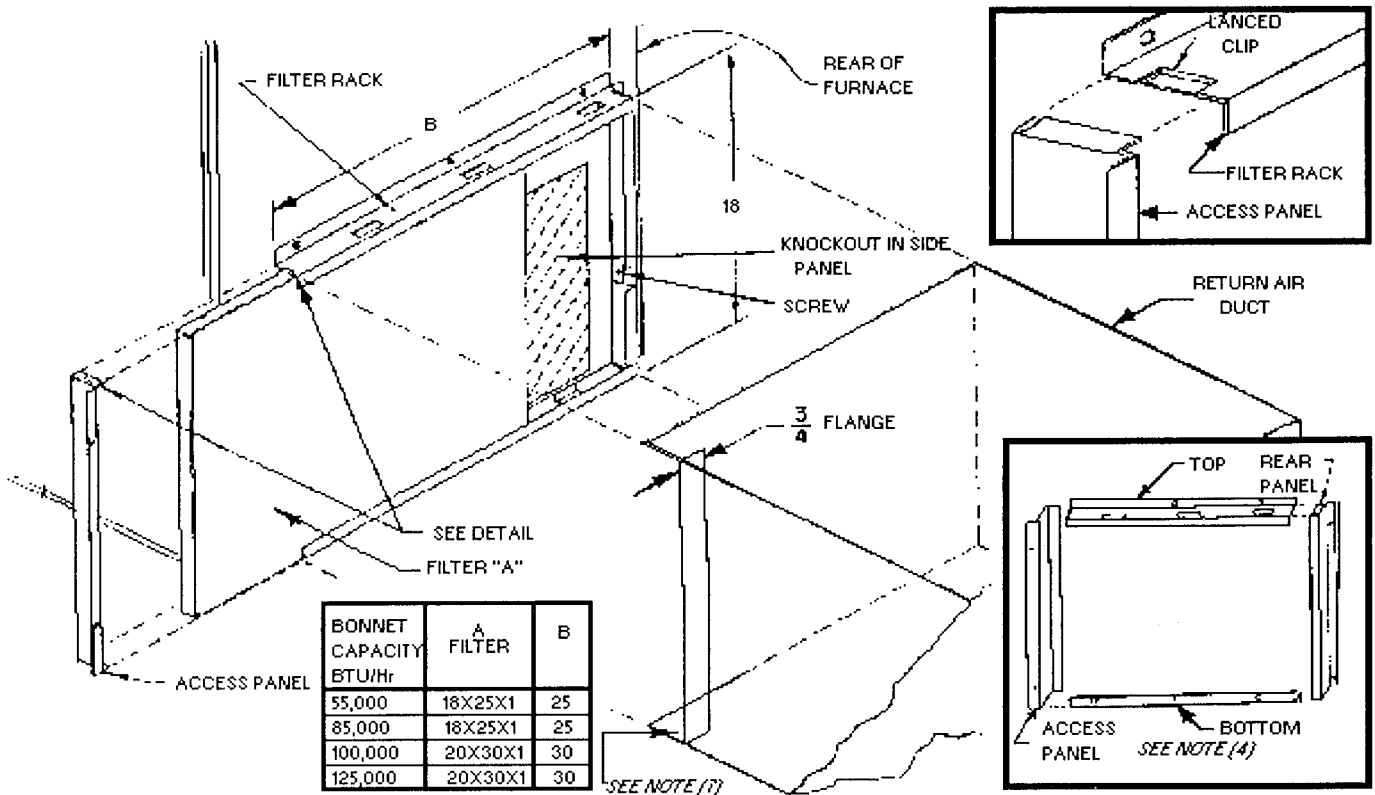

FILTER RACK ARRANGEMENT

Figure 6

When filter rack is used on return air End opening of furnace (either upflow, counterflow, or horizontal):

1. Clip the filter rack pieces together, as shown above.
2. Position the rack centered over the opening in the supply end of the furnace, with access panel toward front of unit.
3. Hold the filter rack against the end of the unit (make sure it is square) and drill the mounting holes in the end of the unit according to the clearance holes in the filter rack top, bottom, and rear panels. **DO NOT SCREW THE ACCESS PANEL IN PLACE!**
4. To fasten return air duct to filter rack, first cut a notch in the return air duct (for filter access panel) to dimension shown in detail. Then slide duct over filter rack.
5. Remove access panel, slide filter in place, then replace access panel.

Minimum filter size and suggested filter material:
(If different type filter is used, it must be an equivalent high airflow capacity.)

BTU INPUT	FILTER SIZE
55,000	18-1/8 X 25
85,000	18-1/8 X 25
100,000	20-1/8 X 30*
125,000	20-1/8 X 30*



* For upflow side return filter size is 18-1/8 x 30.

WARNING

Never operate unit without a filter or with filter access door removed. Failure to adhere to this warning could lead to a hazardous condition which could lead to equipment damage and bodily harm.

Keeping Filters Clean

As a homeowner, this is your most important responsibility. A dirty filter reduces the efficiency of your system, causes erratic performance of controls and could result in damage to the motor or heating element.

1. Inspect filters at regular intervals depending upon dirt conditions. For new homes, check filters every week for 4 consecutive weeks. In all cases, inspect your filters at least every 3 to 4 weeks when the system is in constant operation. Replace or clean filter at least at the beginning of each season (heating and cooling) and thereafter as needed.

2. If the permanent filter supplied with the filter rack becomes dirty, it can be cleaned with cold water and soap.

Be sure that the filter is thoroughly dry before installing back into the furnace.

USER'S INFORMATION

Here's How Your Heating System Works

The furnace operates automatically. It is controlled by a thermostat which you set at the temperature most comfortable to you. When the inside temperature drops below this setting, your thermostat will turn on the heating system.

When the thermostat calls for heat, power from the transformer energizes the fan control board. The fan control energizes the ignition control. The ignition control will light the burner automatically.

The electronic fan control will automatically turn on the blower after 30 seconds. Fan "ON" control is not adjustable. The air moved over the heat exchanger by the blower is warmed and passes through the ducts to the room registers.

When the thermostat is satisfied, the circuit is de-energized and the primary control shuts off the burner. The blower continues to run until the selectable fan off time period has expired.

The heat sensing switch performs as the furnace high temperature limit switch. If the furnace overheats for any reason, the limit switch opens, breaking the circuit to the burner. The blower motor will be energized and as the unit cools the limit switch will close. This will relight the burner and unless the overheating condition is corrected, the furnace will cycle on limit.

This unit is equipped with an interrupted ignition electronic control. If the main burner does not ignite within 15 seconds from the call for heat, the control will go into lockout. The red button on top of the control must be depressed for 3 seconds in order to reset the control. The control can not be reset from the room thermostat.

HEATING

Preparing Furnace For Operation

Before attempting to put your furnace into operation for the heating season you should perform the following procedures.

WARNING

If you do not follow these instructions exactly, a fire or explosion may result causing property damage, personal injury or loss of life.

1. Open all warm air registers and make sure that all return air grills are unobstructed.
2. If a humidifier is installed with your system, open the water supply valve.
3. Set the thermostat to its lowest setting.
4. Turn "ON" the electric power to the furnace.
5. Open the oil supply valve.
6. Check all connections to insure there are no leaks.

Lighting Your Furnace

CAUTION

This furnace is equipped with an interrupted type electronic ignition system. **DO NOT ATTEMPT TO LIGHT WITH A MATCH. DANGER! HIGH VOLTAGE AT IGNITOR.**

1. This appliance is equipped with an ignition device which automatically lights the burner. Do **not** try to light the burner by hand.
2. After preparing the furnace for heating operation (See previous section) and checking for oil, proceed as follows.
3. For heating/cooling system, set the thermostat system switch "HEAT" and the fan switch to "AUTO". Set the thermostat to the desired room temperature and turn on the electrical power to the furnace.
4. The burner should light and the system should be controlled by the thermostat.

Turn Off Furnace

Follow these simple procedures to put your furnace into "retirement" for the summer.

1. Set the thermostat to the lowest setting
2. Turn "OFF" all electric power to the appliance.
3. Turn the oil supply "OFF".
4. If applicable, turn "OFF" water supply to humidifier.
5. If furnace blower will be necessary for cooling system, remember to turn electric power back on when needed for air conditioning.

FOR SERVICE CALL

Supersedes: Nothing

Subject to change without notice. Printed in U.S.A.

Copyright © by Unitary Products Group 1996. All rights reserved.

SHU 1500 197 .88

Codes: SBY,F,L

20074701

Unitary
Products
Group

745 Industrial
Parkway
West

Elyria
Ohio
44035

Limited Warranty

FOR OIL & HORIZONTAL GAS FURNACE HEAT EXCHANGERS

Unitary Products Group (UPG) warrants the primary (and secondary, if applicable) heat exchangers in this product to be free from defects in factory workmanship and material under normal use and service and will, at its option, repair or furnish a replacement heat exchanger, either new or reconditioned, that meets the intended fit, use and function of the original heat exchanger for any heat exchanger furnished by UPG which proves to have such defects within the duration of warranty coverage. Alternatively, UPG may, at its option, extend a replacement allowance to be applied toward the purchase of a new furnace marketed by UPG. The exact amount of the allowance will be determined at the discretion of UPG, based upon current market conditions, but in no case shall this allowance exceed thirty (30) percent of the original consumer purchase price of the furnace excluding such items as ductwork, wiring, piping and installation costs. UPG shall have no responsibility hereunder for installation, shipping, handling or other charges except as specifically provided herein. The duration of warranty coverage, measured from date of initial installation, is as outlined in the following table:

FURNACE HEAT EXCHANGER WARRANTY TABLE		
Furnace Type	Authorized Warranty Period	
	Residential Applications	Non-Residential Applications
Gas 90+ AFUE Horizontal	20 Years	10 Years
Gas 80+AFUE Horizontal	20 Years	
Oil 200 MBH Output or Less	Original Owner - Lifetime	

For your benefit and protection, return the warranty registration card to UPG promptly after installation. This will initiate the warranty period and will allow us to contact you, should it become necessary. In the absence of a recorded warranty card, the warranty period will begin upon product shipment from UPG.

This warranty extends only to the original consumer purchaser and is non-transferable. For this warranty to apply, the product must be installed according to UPG recommendations and specifications, and in accordance with all local, state and national codes, and the product must not be removed from its place of original installation. The warranty period for repair or replacement parts provided hereunder shall not extend beyond the warranty period state above.

This warranty covers the heat exchangers only, and is subject to the following conditions:

1. The furnace has been installed according to accepted practices as recommended by the National Warm Air Heating and Air Conditioning Association, in accordance with all local, state and national codes and in compliance with UPG installation and operation instructions.
2. The furnace has not been operated with an input rate in excess of the rating plate attached to the furnace.
3. The furnace has not been allowed to operate without the use of the proper automatic limit control on the maximum warm air temperature and/or without adequate circulation.
4. The furnace has not been moved from its place of original installation.
5. The furnace is installed so that the combustion air is not contaminated by compounds of chlorine, fluorine or other damaging chemicals (or vapors).
6. The furnace is installed upstream from any cooling or heat pump coil.
7. The furnace installation must be made so that the heat exchangers are not exposed to return air temperatures below stated ratings.

IMPORTANT NOTICE: When a furnace is used in conjunction with an external air conditioner, it must be so installed that no cooled air is allowed to circulate over or around the heat exchanger. This precaution must be observed or the warranty will not apply.

This warranty applies only to products installed in the United States, Canada or Mexico.

EXCLUSIONS

This warranty does not cover any:

1. Shipping, labor, or material charges.
2. Damages resulting from transportation, installation, or servicing.
3. Damages resulting from accident, abuse, fire, flood, alteration, or acts of God (tampering, altering, defacing or removing the product serial number will serve to void this warranty).
4. Damages resulting from use of the product in a corrosive atmosphere.
5. Damages resulting from inadequacy or interruption of electrical service or fuel supply, improper voltage conditions, blown fuses, or other like damages.
6. Cleaning or replacement of filters.
7. Damages resulting from failure to properly and regularly clean air and/or water side of condenser and evaporator.
8. Damages resulting from: (I) freezing of condenser water or condensate; (II) inadequate or interrupted water supply; (III) use of corrosive water; (IV) fouling or restriction of the water circuit by foreign material or like cases.
9. Damages resulting from operation with inadequate supply of air or water.
10. Damages resulting from use of components or accessories not approved by UPG (vent dampers, etc).

(OVER)

HEAT EXCHANGER WARRANTY - CONTINUED

THIS WARRANTY IS IN LIEU OF ALL OTHER WARRANTIES, EXPRESSED OR IMPLIED, INCLUDING THE IMPLIED WARRANTIES OF MERCHANTABILITY AND FITNESS FOR A PARTICULAR PURPOSE.

SOME STATES DO NOT ALLOW THE DISCLAIMER OF IMPLIED WARRANTY, SO THAT THE ABOVE DISCLAIMER MAY NOT APPLY TO YOU.

SOME STATES ALLOW ONLY A PARTIAL LIMITATION ON IMPLIED WARRANTIES TO LIMIT THE DURATION OF IMPLIED WARRANTIES TO THE DURATION OF THE EXPRESS WARRANTY. IN SUCH STATES, THE DURATION OF IMPLIED WARRANTIES IS HEREBY EXPRESSLY LIMITED TO THE DURATION OF THE EXPRESS WARRANTY ON THE FACE HEREOF.

IN NO EVENT, WHETHER AS A RESULT OF BREACH OF WARRANTY OR CONTRACT, TORT (INCLUDING NEGLIGENCE) STRICT LIABILITY OR OTHERWISE, SHALL UPG BE LIABLE FOR SPECIAL, INCIDENTAL, OR CONSEQUENTIAL DAMAGES, INCLUDING BUT NOT LIMITED TO LOSS OF USE OF THE EQUIPMENT OR ASSOCIATED EQUIPMENT, LOST REVENUES OR PROFITS, COST OF SUBSTITUTE EQUIPMENT OR COST OF FUEL OR ELECTRICITY. THE ABOVE LIMITATIONS SHALL INURE TO THE BENEFIT OF UPG' SUPPLIERS AND SUBCONTRACTORS. THE ABOVE LIMITATION ON CONSEQUENTIAL DAMAGES SHALL NOT APPLY TO INJURIES TO PERSONS IN THE CASE OF CONSUMER GOODS.

SOME STATES DO NOT ALLOW THE EXCLUSION OR LIMITATION OF LIABILITY FOR CONSEQUENTIAL OR INCIDENTAL DAMAGES, OR FOR STRICT LIABILITY IN TORT, SO THAT THE ABOVE EXCLUSIONS AND LIMITATIONS MAY NOT APPLY TO YOU.

UPG DOES NOT ASSUME, OR AUTHORIZE ANY OTHER PERSON TO ASSUME FOR UPG, ANY OTHER LIABILITY FOR THE SALE OF THIS PRODUCT.

THIS WARRANTY GIVES YOU SPECIFIC LEGAL RIGHTS. YOU MAY ALSO HAVE OTHER RIGHTS WHICH VARY FROM STATE TO STATE.

TO OBTAIN WARRANTY SERVICE

Notify your installing or servicing dealer, preferable in writing, of the problem as soon as possible after its discovery. Be sure to include product model number, serial number, installation date and the nature of the problem.

If a response is not received within a reasonable time, notify UPG Customer Relations Dept. P.O. Box 1592-362M, York, PA 17405.

Service requests sent to UPG without prior dealer contact will be referred back to a dealer through the UPG Distributor. Because this is a time consuming process, it is in the best interest of the consumer to contact a dealer directly.

For owner's information

PRODUCT MODEL NO. _____ INSTALLATION DATE _____

UNIT SERIAL NO. _____ INSTALLING DEALER _____

Supersedes: 50.05-WC11V (794)

Subject to change without notice. Printed in U.S.A.

Copyright © by Unitary Products Group 1995. All rights reserved.

50.05-WC11V

Unitary
Products
Group

745 Industrial
Parkway
West

Elyria
OH
44035

OIL-FIRED FURNACES 55-125 MBH OUTPUT 80 AFUE

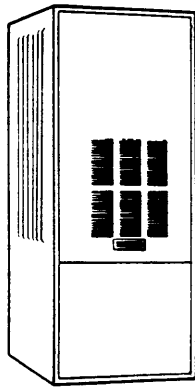

UPFLOW/HORIZONTAL
MODELS - PBFM



DESCRIPTION

These oil-fired furnaces are compact, decorator-styled warm air heating units designed for installation in basements, closets, recreation rooms or garages. Heating capacities range from 55 through 125 MBH bonnet output. All models are designed to accommodate add-on air conditioning. The capacities, cfm's and performance are matched to meet year-round comfort requirements. After the installation of an oil-fired furnace, the air conditioner may be added at any time by adding a compact cooling coil to the furnace, and a small quiet condensing section outside the home.

FEATURES

- **DECORATOR-STYLED CASING** is 22-gauge pre-painted steel for a long lasting a durable finish. Completely insulated to keep heat inside, the exterior casing is at room temperature and cool to the touch.
- **DRAWER-TYPE ASSEMBLY** in the air tube of the burner groups oil lines, fittings, and other components into one assembly for easy inspection and flame adjustment.
- **POWERFUL DIRECT DRIVE CENTRIFUGAL BLOWERS** are engineered for smooth, whisper-quiet operation. Dynamically and statically balanced, rubber isolator mounted, permanently lubricated, it is ideally suited for both heating and cooling service.
- **PBFM MODELS** allow upflow and horizontal left / right applications with a single unit. Easy conversion with minimum change required.
- **BURNER VESTIBULE** permits total encasement of parts for neat appearance while protecting burner and other parts from dust and dirt.
- **BECKETT FLAME RETENTION HEAD BURNER** is standard on all models, finely atomizes the fuel oil for complete combustion, providing high efficiency.
- **CONSTANT LOW BLOWER SPEED OPERATION** for maximum comfort (may be turned off if desired).
- **CADMIUM SULFIDE FLAME DETECTOR** cuts off burner motor in 45 seconds if the oil fails to ignite. The entire furnace is fitted with the latest in automatic controls to assure safe, continuous operation.
- **ELECTRONIC FAN CONTROL** for both comfort and maximum efficiency.
- **HEAT EXCHANGER** is constructed of 409 stainless steel. All seams are mechanically sealed eliminating welding.
- **COMBUSTION CHAMBER** is made of alumina silica fibers which will withstand temperatures up to 2600°F to contain the intense flame created by the retention head burner.

RATINGS AND PHYSICAL DATA

MODEL	HEATING MBH ¹		OIL RATE GPH	AFUE % ²	CFM @ .5 IWG E.S.P. ³	UNIT AMP-ACITY	MAX. OVER-CURRENT PROTECT.	WIRE SIZE AWG	BLOWER		FILTERS QTY. & SIZE	ADD-ON COOLING	
	INPUT	OUTPUT							SIZE	HP		TONS	NOM. CFM
UPFLOW/HORIZONTAL													
PBFMD12F05501	69	55	.50	80	1200	14	20	12	10 x 9	1/3	(1) 18 x 25	2,2-1/2,3	1200
PBFMD12F08501	105	85	.76	80	1200	14	20	12	10 x 9	1/3	(1) 18 x 25	2-1/2,3,3-1/2	1200
PBFMD16F10001	125	100	.90	80	1600	18	35	12	12 x 9	1/2	(1) 20 x 29	3, 3-1/2,4	1600
PBFMD20F12501	154	125	1.12	80	2000	19	35	12	12 x 12	3/4	(1) 20 x 29	3-1/2,4,5	2000

- ¹ For Altitudes above 2000 feet, reduce ratings 4% for each 1000 feet above sea level.
- ² AFUE (Annual Fuel Utilization Efficiency) determined using DOE test procedure, isolated combustion.
- ³ Available external static pressure is at furnace outlet and ahead of cooling unit.

PBFM 055-125 UPFLOW/HORIZONTAL

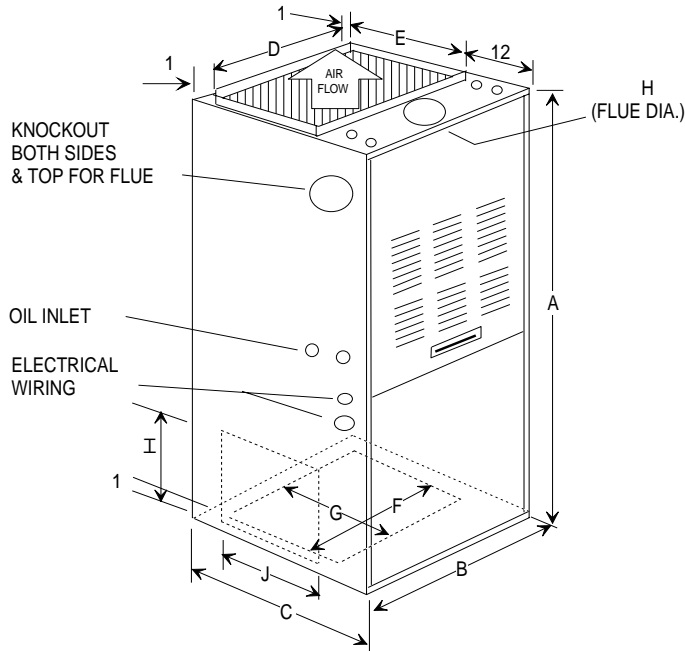

MODEL	DIMENSIONS - INCHES									
	A HEIGHT	B WIDTH	C DEPTH	SUPPLY AIR		BOTTOM RETURN		H FLUE CONNECT.	SIDE RETURN	
				D WIDTH	E DEPTH	F WIDTH	G DEPTH		I HEIGHT	J WIDTH
UPFLOW/HORIZONTAL										
PBFMD12F05501	48	22	30-1/2	20	17	20	17	6**	15	25-1/4
PBFMD12F08501	48	22	30-1/2	20	17	20	17	6**	15	25-1/4
PBFMD16F10001	48	22	35-1/2	20	22	20	22	6**	15	30-1/4
PBFMD20F12501	48	22	35-1/2	20	22	20	22	6	15	30-1/4

NOTES:
 * Flue pipe may be reduced to 5" after elbow.

FIELD WIRING DIAGRAM

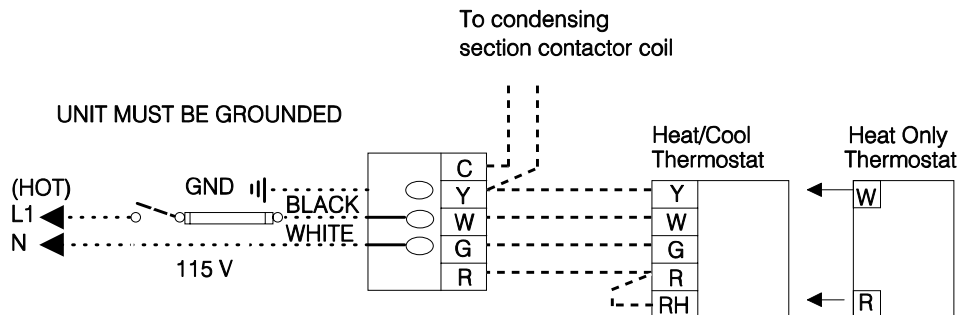

MINIMUM CLEARANCES TO COMBUSTIBLES

CLEARANCES FROM	UPFLOW	HORIZONTAL
Top of furnace casing or plenum	2"	2"
Top of horizontal warm-air duct within 6 ft. of furnace	2"	3"
Flue pipe, measured horizontally or below pipe	4"	4"
Flue pipe, measured vertically above pipe	8"	8"
Any side of supply plenum and warm-air duct within 6 ft of furnace	1"	1"
Front of furnace	8" *	24"
Sides of furnace	0"	2"
Rear of furnace	1"	1"
Bottom of furnace	0" ¹	0" ¹

¹ Floor may be combustible.
 * 24" required for servicing.

BLOWER PERFORMANCE

UPFLOW/HORIZONTAL

MODEL	BLOWER SPEED	EXTERNAL STATIC PRESSURE, INCHES W.C.									
		0.1	0.2	0.3	0.4	0.5	0.6	0.7	0.8	0.9	1.0
PBFMD12F05501	LOW	825	815	790	760	720	655	600	525	425	290
	MED	1185	1160	1125	1085	1030	965	875	790	660	560
	HIGH	1570	1505	1435	1365	1290	1200	1095	685	865	885
PBFMD12F08501	LOW	1140	1130	1110	1100	1035	960	875	780	645	490
	MED	1405	1375	1315	1255	1185	1120	1035	920	800	635
	HIGH	1665	1625	1610	1535	1455	1365	1165	1045	925	780
PBFMD16F10001	LOW	1340	1330	1320	1290	1270	1215	1180	1125	1045	990
	MED	1695	1645	1615	1565	1530	1465	1410	1335	1255	1165
	HIGH	1965	1915	1865	1805	1745	1665	1590	1515	1445	1345
PBFMD20F12501	LOW	1535	1495	1450	1420	1365	1330	1275	1205	1125	1035
	MED	2000	1965	1890	1795	1755	1690	1625	1555	1480	1375
	HIGH	2240	2170	2085	1980	1935	1820	1750	1665	1590	1510

ACCESSORIES - FOR FIELD INSTALLATION

THERMOSTATS – Remote, wall-mounted, low voltage, for both heating/cooling applications. Refer to Thermostat Price Page.

2-STAGE FUEL PUMPS – Single stage pump in all 55 thru 125 MBH output units. Field convert single stage to two-stage by ordering part number 026-30270-000, or latest number.

LUXAIRE[®]
Heating ■ Air Conditioning

Code: EBL

650.06-TG2L

Supersedes: 660.06-TG2L (1196)
Subject to change without notice. Printed in U.S.A.
Copyright © by Unitary Products Group 1997. All rights reserved.

Unitary Products Group
745 Industrial Parkway West
Elyria, OH 44035