

# ACCESSORY KIT INSTALLATION MANUAL

## ELECTRIC HEATER ACCESSORY (6HK SERIES)

FOR USE WITH MODELS: AP / AE / AVC / AHR / AHE / AHV / MP / ME / MVC / RFCX\*E / RFCX\*P / PHE / PCE

### GENERAL INFORMATION

#### ⚠ WARNING

##### **ELECTRICAL SHOCK HAZARD**

Installation or repairs made by unqualified persons can result in hazards to you and others. Installation must conform with local building codes or, in the absence of local codes, with National Electrical Code ANSI/NFPA 70-1996 or current edition.

The information contained in this manual is intended for use by a qualified service technician familiar with safety procedures and equipped with the proper tools and test instruments.

Shut OFF electric power at unit disconnect and/or service panel before beginning the following procedures.

Failure to carefully read and follow all instructions in this manual can result in malfunction, property damage, personal injury, and/or death.

Verify edges of foil faced insulation are not in contact with any exposed electrical connections.

These instructions cover the installation of the following electric heater models with the AP / AE / AVC / AHR / AHE / AHV / RFCX\*E / RFCX\*P single piece air handlers, the MP / ME / MVC modular air handlers, and the PHE / PCE residential package (Respac) units. The 6HK series of electric heat kits use a single polarized plug to easily connect the equipment power and controls.

These electric heat accessories are used for applications of electric heat, cooling with electric heat, and heat pump with electric heat. Each of the air handler and Respac models are approved for use with specific electric heat accessories. The unit installation instructions, technical guide, or name plate list the possible combinations and other important electrical data and limitations. Refer to unit instructions for further electrical specifications.

#### ⚠ CAUTION

Unit is approved for zero clearance to combustible material and when equipped with electric heat a minimum clearance of one inch must be maintained on all sides of the supply duct and/or plenum for three feet as shown in the detail in Figure 1 for the 20kw and 25 kW electric heaters only.

#### NOTICE

In some horizontal applications, the service disconnects on the electric heat kits must be rotated 180° so the up position of the disconnect is the ON position. This service disconnect orientation change is required by UL1995, Article 26.19 (in reference to all circuit breakers).

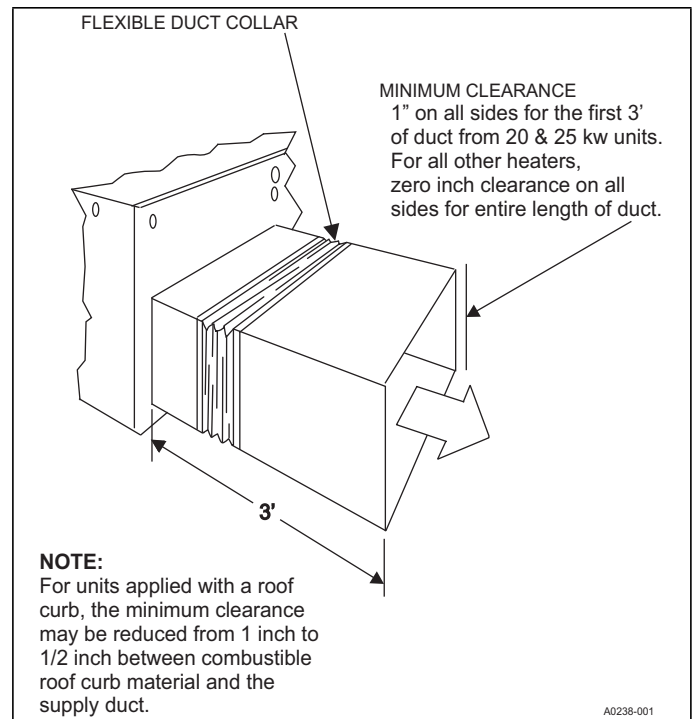

FIGURE 1: Duct Work Clearance

#### NOTICE

The electric heat accessory should be installed before the supply air duct is attached to the supply air opening flanges.

#### CLEARANCE

All installations of the 6HK electric heater kits are approved for zero-clearance to combustibles when the minimum speed tap on the blower motor is set per the equipment installation instruction or nameplate. See equipment installation instructions for more information on changing motor speed taps.

## MODELS

TABLE 1: Models Covered

Heater kW @ 240V	1 Phase Heat Kit <sup>1,2</sup>	3 Phase 208V/230V Heat Kits (PHE, PCE, AHR, AHE, AHV, RFCX*E1, RFCX*P1,)	3 Phase 208V/230V Heat Kits (AP, AE, AVC, RFCX*E2, RFCX*P2, MP, ME, MVC)	3 Phase <sup>3</sup> 460V Heat Kits
2.4	6HK(0,1)6500206	–	–	
4.8	6HK(0,1)6500506	–	–	
7.7	6HK(0,1)6500806	–	–	
9.6	6HK(0,1)6501006	6HK06501025	6HK36501025	6HK06501046
12.5	6HK(1,2)6501306	–	–	
14.4	6HK(1,2)6501506	6HK06501525	6HK36501525	6HK06501546
17.3	6HK(1,2)6501806	6HK06501825	6HK36501825	6HK06501846
19.2	6HK(1,2)6502006	6HK16502025	6HK46502025	6HK06502046
24.0	6HK(1,2)6502506	6HK16502525	6HK46502525	6HK06502546

1. (0,1) - 0 = no service disconnect OR 1 = with service disconnect.

2. (1,2) - 1 = with service disconnect, no breaker jumper bar OR 2 = with service disconnect & breaker jumper bar.

3. Revision D or later must be used on MP 460V models.

## NOMENCLATURE - ELECTRICAL

6	Product Category	6 = Electric Heat for AP/AE/AVC/MP/ME/MVC/AHR/AHE/AHV/RFCX*E/RFCX*P Residential Air Handlers and PHE/PCE Residential Packages
HK	Family Identifier	HK = Electric Heater
1	Power Connection	0 = Terminal Block
		1 or 3 = Service Disconnect
		2 or 4 = Service Disconnect & Single Point Wiring Kit
65	Class Identifier	65 = Electric Heater
002	Electric Heat, Nom. kW	002=2.5kW; 005=5kW; 008=8kW; 010=10kW; 013=13kW; 013=13kW; 015=15kW; 018=18kW; 020=20kW; 025=25kW
25	Voltage Code	06 = 208/230-1-60; 25 = 208/230-3-60; 46 = 460-3-60
C	Style Letter	C = Indicates sequential change of component style
D	Style Letter	D = Changed limit control cut out specification

### AIR HANDLER ELECTRIC HEAT KIT INSTALLATION (AP / AE / AVC / MP / ME / MVC / AHR / AHE / AHV / RFCX\*E / RFCX\*P)

Installation is the same for all air handler operating positions: upflow, downflow, and horizontal right or left. Installation of the Heater Kit should be done prior to unit installation. Refer to Figure 2 or 3 for depiction of components.

1. Ensure that there is no electrical power going to the unit.

## ⚠ CAUTION

*Be aware that some units may have multiple power sources.*

2. Remove air handler blower access panel.
3. If the heat kit is being installed in model AHR, AHE, AHV or RFCX\*1, move the service disconnect bracket to Position B as shown in Figure 2.
4. If Heat Kit has service disconnects (if heat kit does not contain service disconnects, skip to step 5):
  - a. Examine the heat kit and take note of the number of service disconnects it has. Remove the appropriate number of service disconnect knockouts from the front access panel of the air handler unit.

- b. Cut blower access panel insulation behind the service disconnect plate and remove to open the area for the service disconnects to protrude through the front access panel and to provide clearance for service disconnects and single point wiring entry kit.
  - c. Replacement non-foil faced insulation for the exposed front panel may then need to be added. Add rubber gasket to inside of door for sealing.
5. Remove and recycle the duct cover from back panel of air handler control and wiring compartment.

## ⚠ CAUTION

*To prevent damage, carefully pass the accessory heating element through the rectangular opening in the discharge duct. Element mounting plate must be secured with 4 screws.*

6. Install electric heat accessory.
  - a. Position and insert heat kit into opening in air handler.
  - b. Align mount holes and fasten the Heat Kit to the air handler unit with 4 duct cover screws.

7. Remove and discard the air handler power connection wiring that is for use without electric heat (the connector containing only the red and black wires) from the 6 pin connector.
8. Connect the heat kit 6 pin socket connector to the control/power 6 pin connector in the air handler. The end terminals are "D" shaped to ensure polarization of the connector.
9. Mark an X in the appropriate box on the indoor unit rating plate for the particular heater installed.
10. Refer to the unit rating plate for the minimum blower speed required for the model heat kit installed, and set blower speed accordingly.

## ⚠ WARNING

Verify edges of foil faced insulation are not in contact with any exposed electrical connections.

## NOTICE

All wiring must comply with local and National Electrical Code requirements. Read and heed all unit caution labels.

## NOTICE

An optional service disconnect cover can be applied to seal/protect the Service Disconnects (S1-02435672000).

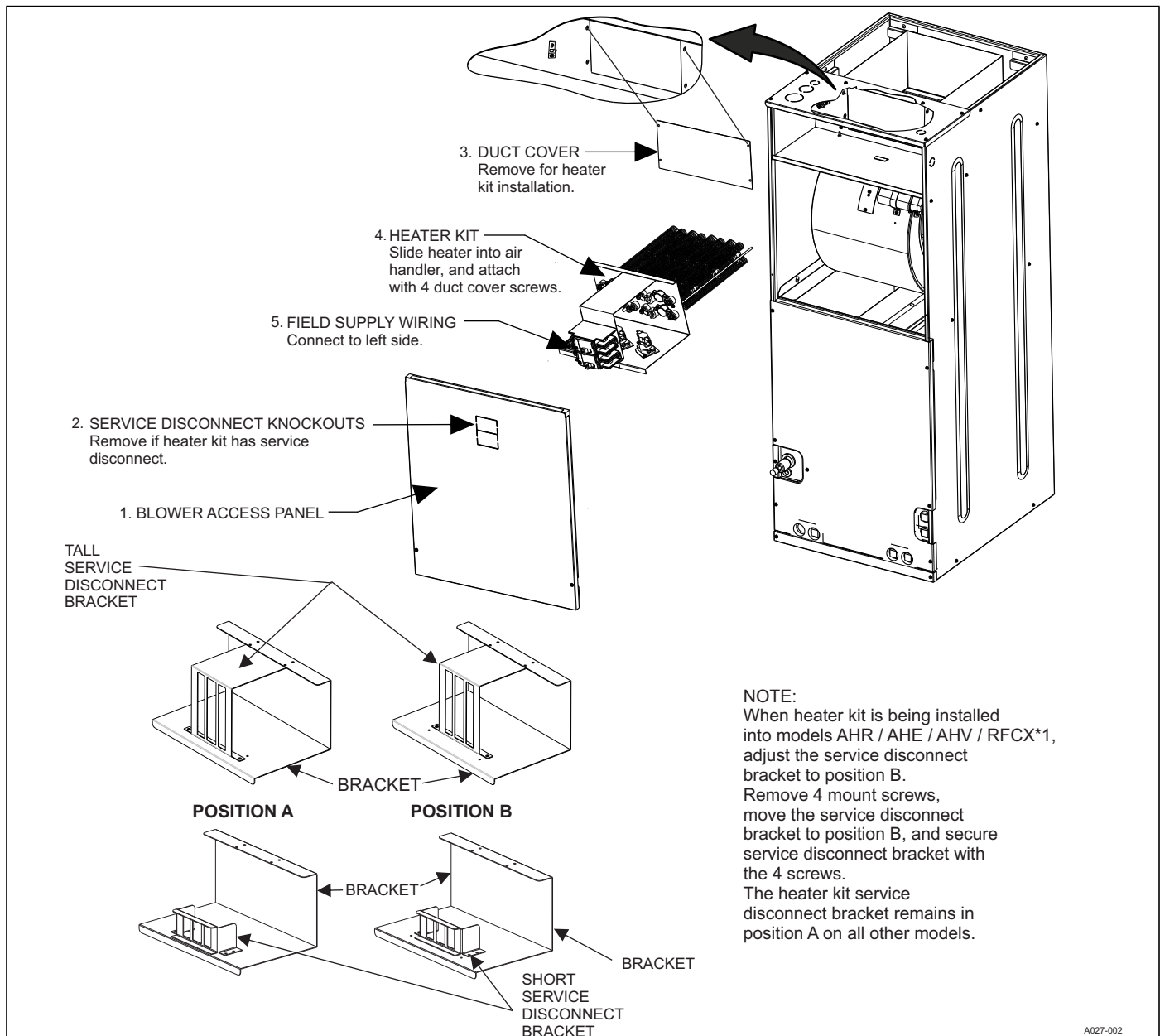

**FIGURE 2:** Air Handler Heater Installation (AHR / AHE / AHV / RFCX\*E1 / RFCX\*P1)

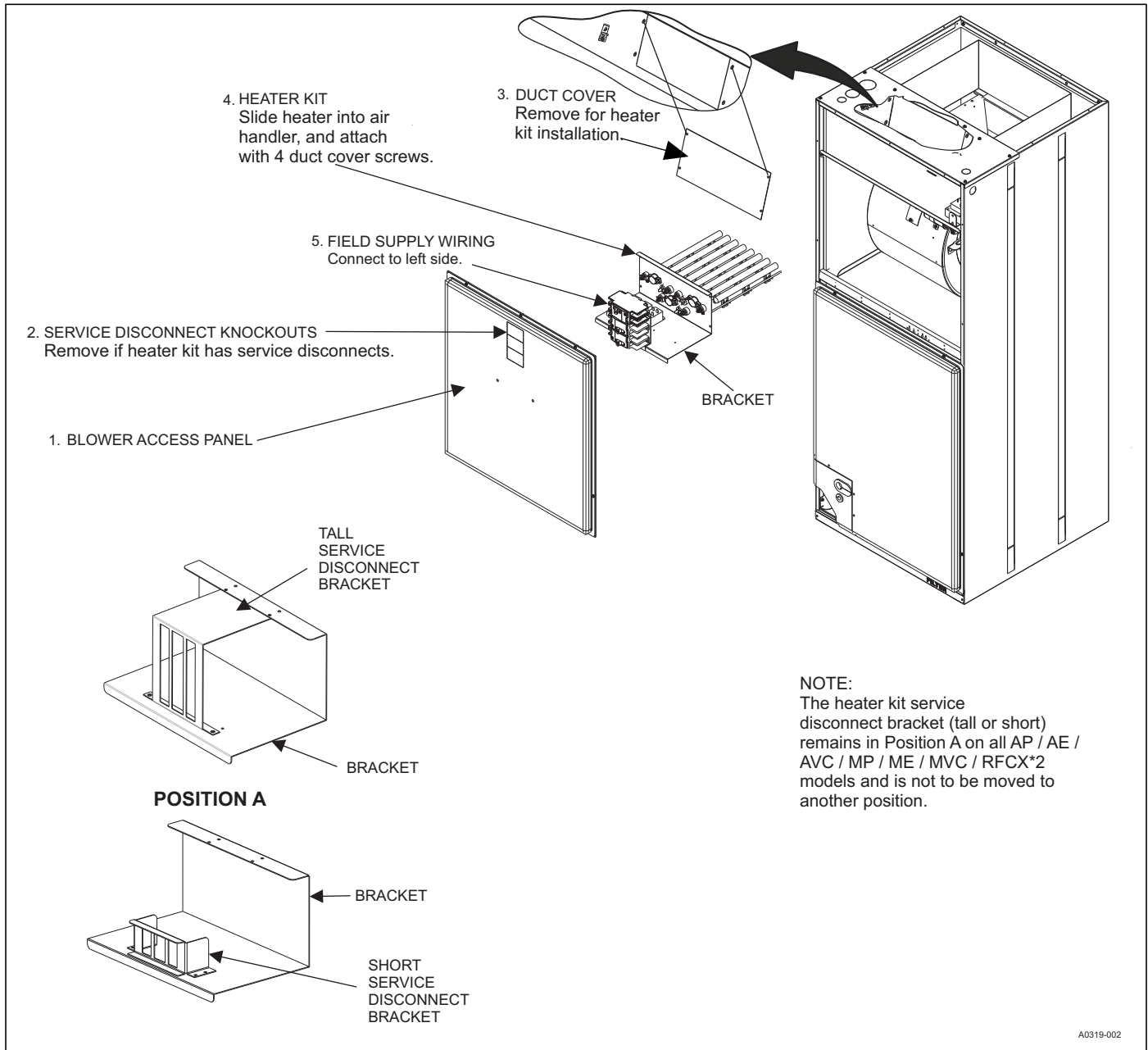

**FIGURE 3:** Air Handler Heater Installation (AP / AE / AVC / MP / ME / MVC / RFCX\*E2 / RFCX\*P2)

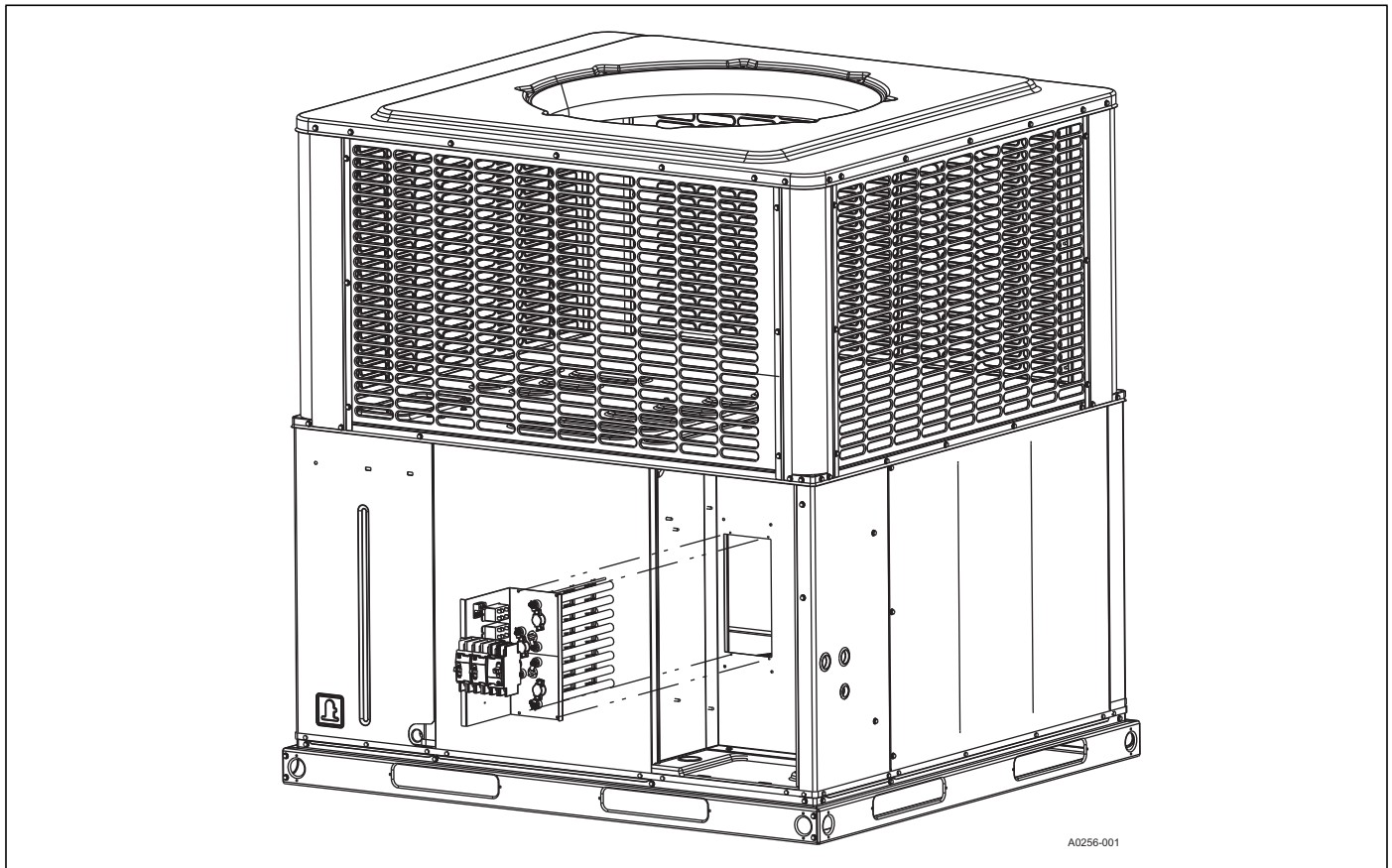

**FIGURE 4:** Respac Heater Installation (PHE / PCE)

#### RESPAC ELECTRIC HEAT KIT INSTALLATION (PHE / PCE)

Installation is the same for both Respac models. Installation of the Heater Kit should be done prior to unit installation. Refer to Figure 4 for depiction of components.

1. Ensure that there is no electrical power going to the unit.
2. Remove the electrical/controls access panel.
3. Remove and discard the patch plate exposing the opening for the installation of the electrical heat kit. Refer to Figure 4.

#### ▲ CAUTION

*To prevent damage, carefully pass the accessory heating element through the open rectangular mounting position. Element mounting plate must be secured with 4 screws.*

4. Install the electrical heat kit accessory.

#### NOTICE

*The service disconnects on the electric heat kit must be rotated 180° so that the UP position of the disconnect is the ON position. This service disconnect orientation change is required by UL 1995, Article 26.19 (in reference to all circuit breakers).*

5. Connect the heat kit's 6 pin socket connector to the control/power 6 pin connector in the Respac. The end terminals are "D" shaped to ensure polarization of the connector.
6. Mark an X in the appropriate box on the outdoor unit rating plate for the particular heater installed.

Refer to the unit rating plate for the minimum blower speed required for the model heat kit installed, and set blower speed accordingly.

#### ▲ WARNING

*Verify edges of foil faced insulation are not in contact with any exposed electrical connections.*

#### NOTICE

*All wiring must comply with local and National Electrical Code requirements. Read and heed all unit caution labels.*

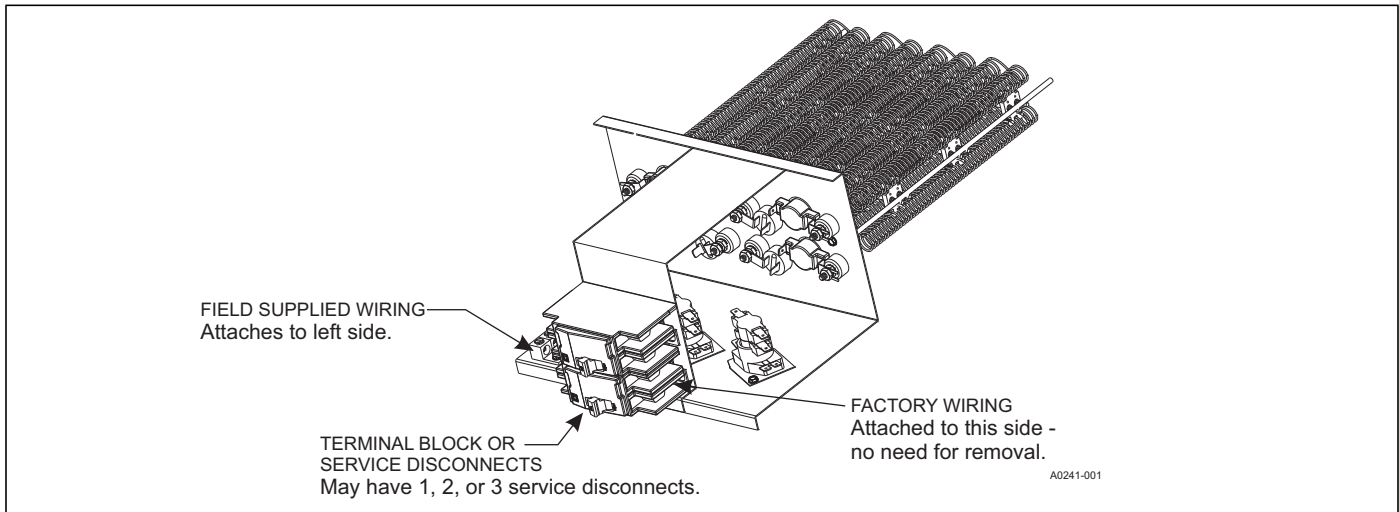
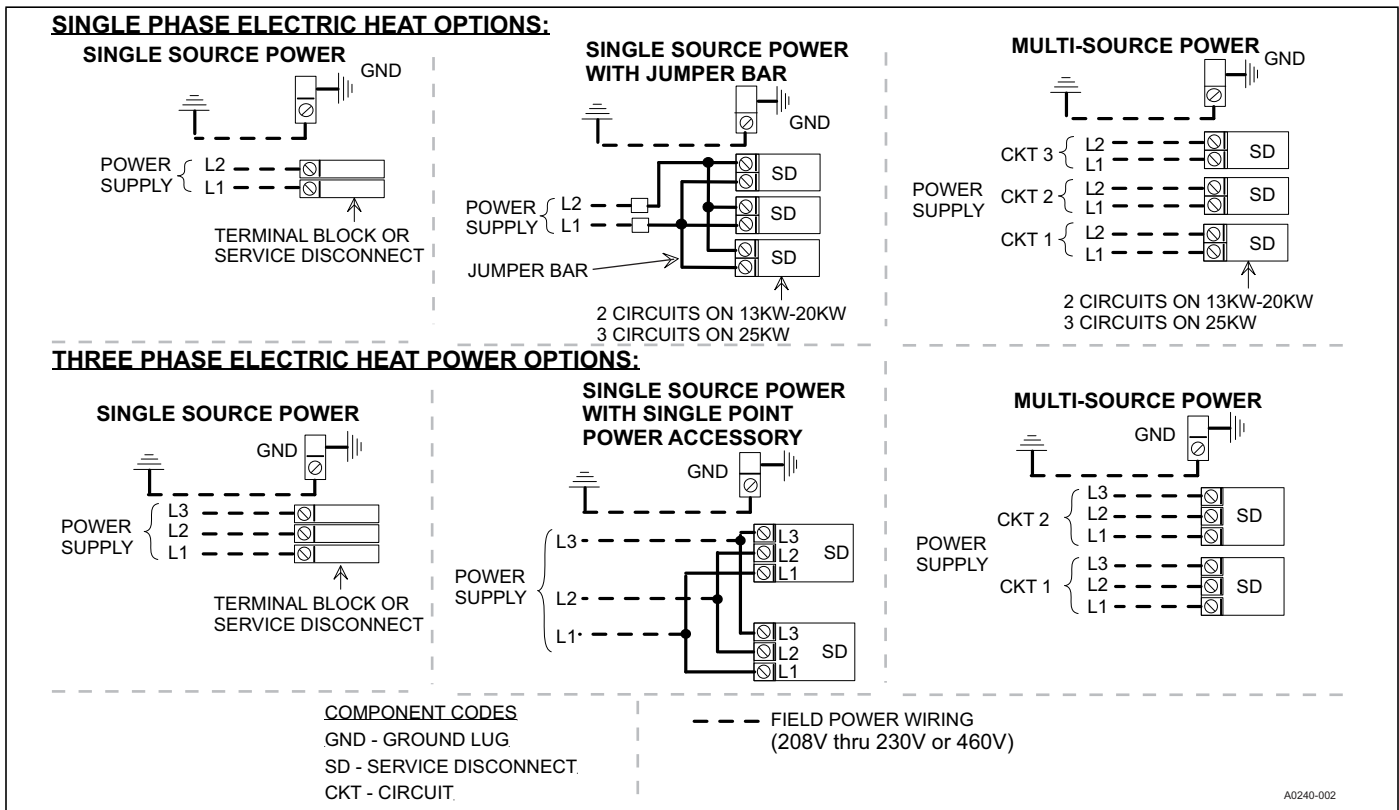

**FIGURE 5:** Heat Kit Connection

**LINE POWER CONNECTIONS**

Power may be brought into the air handler through the outlet air end of the unit (top left when unit is vertical) or the left side panel. For the ResPac, power may be brought into the electric/controls area through the power supply provisions in the bottom or right side of the unit. To minimize air leakage of any unit, seal the field wiring entry point.

Field wiring connects to heat kits with service disconnect or terminal block depending on the heat kit model. The multiple circuit, single phase heater kits have options for a single power supply. For the 3 phase 20kW and 25kW kits with multiple circuits, a single point power accessory kit may be ordered separately. A ground lug is provided on the kits. Refer to unit instructions for electrical specifications. See Figures 5 and 6.



**FIGURE 6:** Air Handler and Respac Electric Heat Power

## ELECTRIC HEATERS & OPERATING CONTROLS

### NOTICE

*For blower speed connections, electrical information and wiring diagrams, see indoor unit installation instructions.*

### NOTICE

*The electric heaters have both auto resettable and fusible link thermal limit controls.  
If failure occurs, this fusible link thermal limit control must be replaced with a direct replacement.*

## LOW VOLTAGE CONTROL CONNECTIONS

The low voltage transformer is standard on all models.

### NOTICE

*All wiring must comply with local and national electrical code requirements. Read and heed all unit caution labels.*

The 24 volt power supply is provided by an internally wired low voltage transformer which is standard on all air handler and Respac models. Field supplied low voltage wiring can exit the unit on the top right hand corner of the air handler or the right hand side panel of the air handler (refer to Figure 2 or 3). Respac models have provisions for low voltage wiring exits in the bottom or right side of the unit (refer to Figure 4). Remove desired knockout and pierce foil faced insulation to allow wiring to pass through. Use as smallest hole possible to minimize air leakage. Install a 7/8" plastic bushing in the selected hole and keep low voltage wiring as short as possible inside the control box. To further minimize air leakage, seal the wiring entry point at the outside of the unit. The field wiring is to be connected at the screw terminals of the control board or on low voltage wiring leads using twist-on wire connectors.

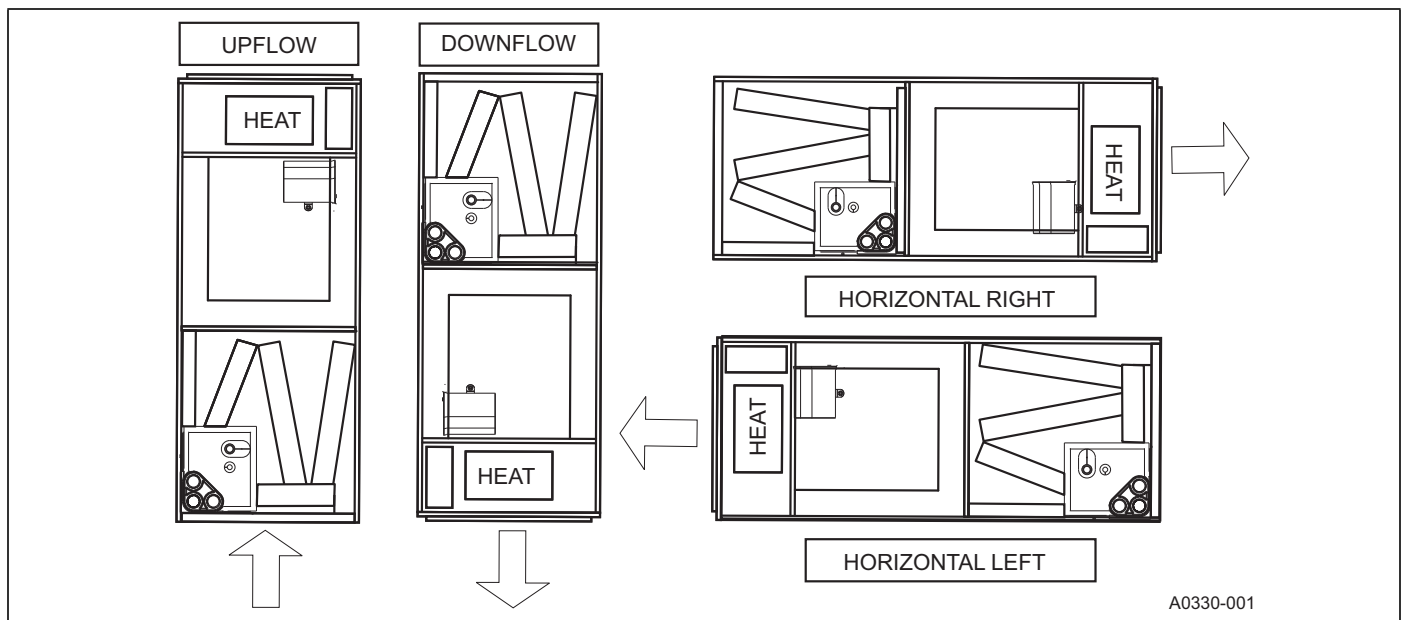

A0330-001

**FIGURE 7:** Typical Air Handler Installed Application

# NOTES