

95G2V

PRODUCT SPECIFICATIONS

TWO STAGE VARIABLE SPEED GAS FURNACE

FORM NO. 95G2V-100 (05/2017)



CONFIGURATIONS

- Upflow / Horizontal
- Downflow

VENTING

- 2-speed induced draft motor with stainless steel shaft, steel ball bearings, and fan cooled for long life
- Certified for direct vent (2-pipe) or non-direct (1-pipe) applications

INSTALLATION FEATURES

- Left or right gas and electric entry
- Zero step horizontal conversion
- Removable floor base (upflow/horizontal units) for bottom return air
- All models comply with California's South Coast Air Quality Management district Low NOx requirements

HEAT EXCHANGER DESIGN

- Aluminized steel primary heat exchanger with crimped non-welded construction
- AL29-4C Stainless steel secondary heat exchanger

BURNERS

- Aluminized steel in shot burners for smooth ignition
- Isolated burner enclosure for quiet operation

CABINET CONSTRUCTION

- Compact 33" height
- Standardized widths for easy coil fit
- Heat exchanger compartment is insulated to increase efficiency and reduce sound levels

AIR DELIVERY SYSTEM

- Efficient ECM variable speed blower motor
- Motor features "soft start" and "soft stop" for quiet operation
- Active and passive dehumidification feature
- Easily removable slide-out blower design
- Dynamically balanced blower wheel with resilient motor mounts for smooth and quiet operation

CONTROLS

- Two stage gas valve
- Integrated ignition and fan control
- System Sentry™ control retains last five (5) fault codes with push button memory recall, regardless of power interruption
- Hot surface ignition system uses silicon nitride ignitor
- Control features 120 volt electronic air cleaner and humidifier terminals
- Control circuit is fuse protected
- Color coded control wiring
- Compatible with single or two stage thermostats for heating.
- Two stage thermostat is recommended when installed with two stage cooling unit.

WARRANTY

10 year limited parts warranty / lifetime heat exchanger warranty available. See limited warranty document for details.



MODEL NUMBER GUIDE

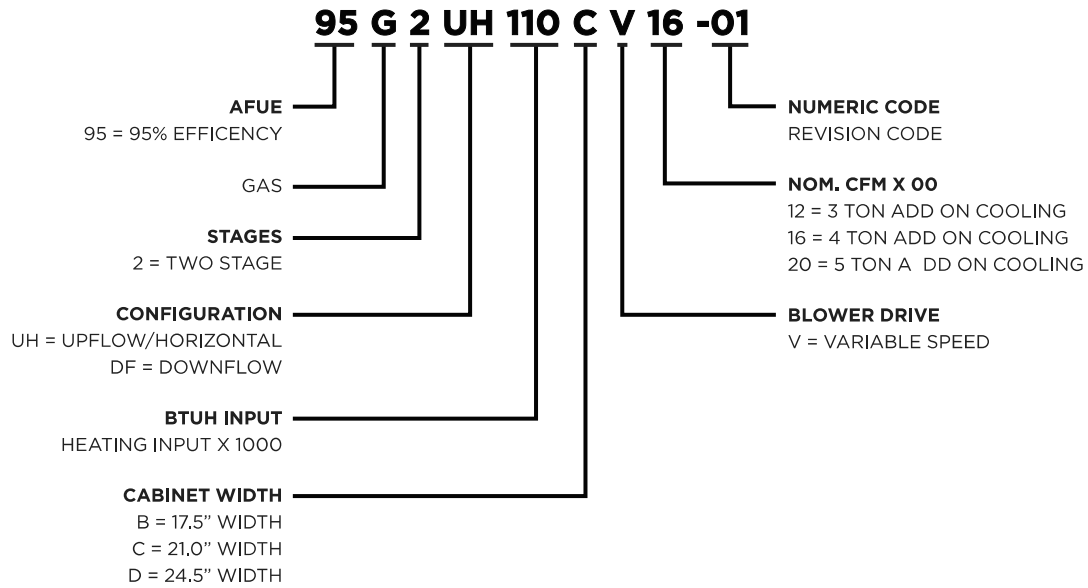

PHYSICAL AND ELECTRICAL DATA

	Model	1st Stage		2nd Stage		AFUE (ICUS)	Nom. Cooling Capacity (tons)	Gas Inlet (in.)	Volts/ Hz/ Phase	Min. Time Delay Breaker or Fuse	Nominal F.L.A.	Trans. (V.A.)	Approx. Weight (lbs.)
		Input (Btuh)	Output (Btuh)	Input (Btuh)	Output (Btuh)								
UPFLOW/HORIZONTAL	95G2UH045BV12	29,000	28,000	44,000	42,000	95.0	3	1/2	120-60-1	15	7.7	40	130
	95G2UH070BV12	43,000	41,000	66,000	62,000	95.0	3	1/2	120-60-1	15	7.7	40	138
	95G2UH090CV12	57,000	55,000	88,000	84,000	95.0	3	1/2	120-60-1	15	7.7	40	154
	95G2UH090CV20	57,000	55,000	88,000	85,000	95.0	5	1/2	120-60-1	20	12.8	40	166
	95G2UH110CV20	72,000	70,000	110,000	105,000	95.0	4	1/2	120-60-1	15	12.8	40	173
	95G2UH135DV20	88,000	84,000	132,000	126,000	95.0	5	1/2	120-60-1	20	12.8	40	188
DOWNFLOW	95G2DF045BV12	29,000	28,000	44,000	43,000	95.0	3	1/2	120-60-1	15	7.7	40	131
	95G2DF070BV16	43,000	42,000	66,000	64,000	95.0	4	1/2	120-60-1	15	10.1	40	136
	95G2DF090CV20	57,000	56,000	88,000	85,000	95.0	5	1/2	120-60-1	20	12.8	40	164
	95G2DF110CV20	72,000	70,000	110,000	106,000	95.0	5	1/2	120-60-1	20	12.8	40	176

Note: For vent length and clearances to combustibles, please reference installation instructions.

FILTER REQUIREMENT DATA

Airflow Descriptor	Disposable Filters	Cleanable Filters
	Minimum Area (sq. in.)	Minimum Area (sq.in.)
12	576	288
16	768	384
20	960	480

1. The Airflow Descriptor is the two digits following the "B", "C", or "D" in the model number; e.g. "20" is the Airflow Descriptor.
 2. Areas shown for permanent filters are based on filters rated at 600 feet per minute face velocity.

BLOWER PERFORMANCE DATA (UPFLOW / HORIZONTAL)

	Model	Motor Size (hp)	Blower Size	Heating Temp. Rise (°F)	Heating CFM @ .10" - .80" w.c.				Cooling Stage	Cooling CFM @ .10" - .80" w.c.				Speed Adjust.
					Setting "D"	Setting "C"	Setting "B"	Setting "A"		Setting "D"	Setting "C"	Setting Upflow/Horizontal	Setting "A"	
UPFLOW / HORIZONTAL	95G2UH045BV12	1/2	10x9	35-65 High Fire	745	875	990	1005	2nd Stage	905	1075	1210	1370	+
					685	765	895	910		815	980	1120	1255	Norm
					610	695	785	810		720	885	1020	1135	-
				20-50 Low Fire	685	765	895	910	1st Stage	595	760	865	980	+
					620	705	800	820		540	660	785	890	Norm
					545	625	715	725		485	600	695	790	-
	95G2UH070BV12	1/2	10x9	50-80 High Fire	965	1130	1255	1400	2nd Stage	860	1060	1215	1365	+
					880	990	1140	1295		810	960	1130	1265	Norm
					810	890	1030	1170		705	840	1005	1140	-
				25-55 Low Fire	940	1070	1195	1345	1st Stage	600	740	840	970	+
					830	965	1100	1235		555	665	770	855	Norm
					755	840	975	1130		500	600	680	790	-
	95G2UH090CV12	1/2	10x9	60-90 High Fire	1060	1135	1240	1430	2nd Stage	875	1040	1210	1360	+
					960	1040	1120	1310		800	945	1100	1245	Norm
					830	935	980	1175		720	840	970	1115	-
				30-60 Low Fire	960	1040	1120	1310	1st Stage	625	710	830	950	+
					875	945	995	1195		565	670	760	860	Norm
					790	840	920	1080		520	610	685	785	-
	95G2UH090CV20	1	11x11	40-70 High Fire	1450	1565	1725	1865	2nd Stage	1385	1595	1820	2020	+
					1310	1450	1585	1690		1225	1465	1645	1885	Norm
					1155	1305	1450	1545		1065	1320	1504	1675	-
				25-55 Low Fire	1120	1265	1420	1520	1st Stage	935	1055	1275	1465	+
					965	1120	1285	1395		835	980	1120	1335	Norm
					865	950	1120	1235		740	870	1010	1150	-
95G2UH110DV20	1	11x11	45-75 High Fire	1560	1760	1905	2080	2nd Stage	1310	1560	1745	1955	+	
				1415	1610	1740	1930		1220	1405	1570	1795	Norm	
				1285	1485	1560	1745		1075	1270	1430	1635	-	
			35-65 Low Fire	1155	1325	1420	1565	1st Stage	935	1065	1245	1405	+	
				1055	1200	1310	1480		865	970	1145	1280	Norm	
				935	1075	1170	1315		790	890	1025	1165	-	
95G2UH135DV20	1	11x11	45-75 High Fire	1560	1760	1905	2080	2nd Stage	1310	1560	1745	1955	+	
				1415	1610	1740	1930		1220	1405	1570	1795	Norm	
				1285	1485	1560	1745		1075	1270	1430	1635	-	
			35-65 Low Fire	1155	1325	1420	1565	1st Stage	935	1065	1245	1405	+	
				1055	1200	1310	1480		865	970	1145	1280	Norm	
				935	1075	1170	1315		790	890	1025	1165	-	

BLOWER PERFORMANCE DATA (DOWNFLOW)

	Model	Motor Size (hp)	Blower Size	Heating Temp. Rise (°F)	Heating CFM @ .10" - .80" w.c.				Cooling Stage	Cooling CFM @ .10" - .80" w.c.				Speed Adjustment
					Setting "D"	Setting "C"	Setting "B"	Setting "A"		Setting "D"	Setting "C"	Setting "B"	Setting "A"	
DOWNFLOW	95G2DF045BV12	1/2	10x9	35-65 High Fire	735	830	1015	1210	2nd Stage	895	1050	1210	1360	+
					680	750	930	1070		805	965	1105	1250	Norm
					625	695	835	1000		735	865	1000	1130	-
				20-50 Low Fire	705	780	975	1110	1st Stage	640	755	850	975	+
					655	730	890	1055		580	695	780	880	Norm
					595	670	790	960		545	645	720	795	-
	95G2DF070BV16	3/4	11x10	35-65 High Fire	1110	1305	1430	1700	2nd Stage	1110	1340	1575	1800	+
					995	1175	1315	1520		995	1230	1420	1650	Norm
					880	1055	1170	1365		880	1085	1290	1460	-
				25-55 Low Fire	860	1020	1140	1340	1st Stage	740	915	1055	1255	+
					795	910	1030	1230		660	820	940	1120	Norm
					680	825	910	1085		575	735	850	995	-
	95G2DF090CV20	1	11x11	40-70 High Fire	1395	1555	1695	1825	2nd Stage	1335	1600	1750	1980	+
					1275	1395	1585	1670		1225	1450	1630	1830	Norm
					1145	1265	1405	1525		1120	1270	1450	1660	-
				30-60 Low Fire	1130	1230	1365	1475	1st Stage	955	1115	1265	1450	+
					1040	1130	1250	1340		855	1005	1150	1285	Norm
					910	1025	1130	1210		750	890	1060	1170	-
	95G2DF110CV20	1	11x11	45-75 High Fire	1595	1795	1955	2140	2nd Stage	1335	1585	1790	2010	+
					1450	1615	1795	1975		1220	1440	1630	1865	Norm
					1290	1460	1610	1795		1100	1275	1475	1680	-
				35-65 Low Fire	1165	1305	1465	1625	1st Stage	920	1095	1265	1440	+
					1055	1185	1315	1475		830	965	1130	1290	Norm
					930	1070	1180	1320		735	860	1035	1155	-

DIMENSIONS (IN.)

	Model	A	B	C	D
UPFLOW/HORIZONTAL	95G2UH045BV12	17-1/2	16-3/8	16	7-5/8
	95G2UH070BV12	17-1/2	16-3/8	16	7-5/8
	95G2UH090CV12	21	19-7/8	19-1/2	9-3/8
	95G2UH090CV20	21	19-7/8	19-1/2	9-3/8
	95G2UH110CV20	21	19-7/8	19-1/2	9-3/8
	95G2UH135DV20	24-1/2	23-3/8	23	11-1/8
DOWNFLOW	95G2DF045BV12	17-1/2	16-3/8	16	15-1/2
	95G2DF070BV16	17-1/2	16-3/8	16	15-1/2
	95G2DF090CV20	21	19-7/8	19-1/2	19
	95G2DF110CV20	21	19-7/8	19-1/2	19

Front View

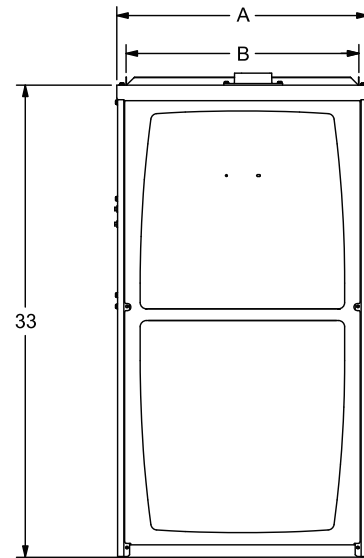

Upflow / Horizontal

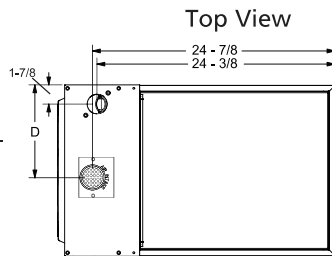

Downflow

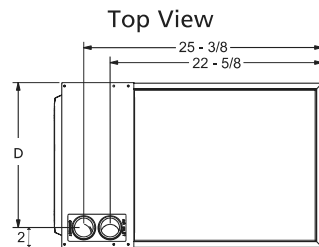

Right Side View

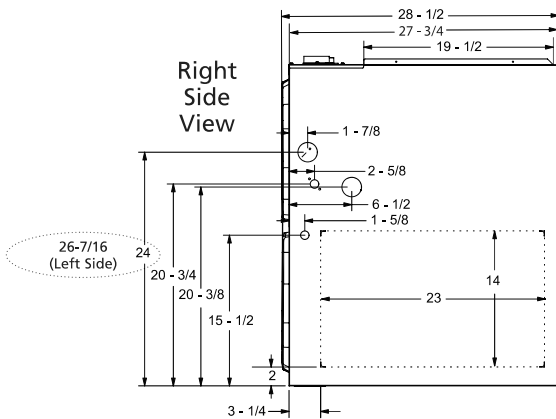

Right Side View

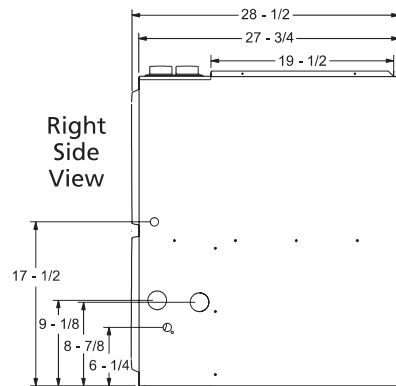

Bottom View

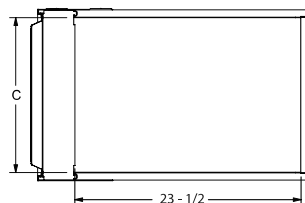

Bottom View

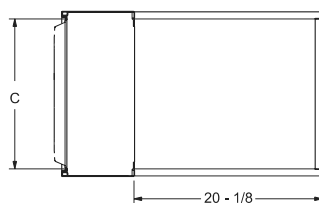

ACCESSORY LIST

CATALOG NUMBER	DESCRIPTION
EXTERNAL FILTER RACK KITS	
1.841018	1 pack (16 x 25)
1.841039	10 pack (16 x 25)
NATURAL TO LP KITS	
11K48	2-Stage - 90
11K47	High Altitude 2-Stage (>7500')
RETURN AIR BASE	
68W62	17.5" B Width
68W63	21.0" C Width
68W64	24.5" D Width
DOWNFLOW COMBUSTIBLE FLOORING BASE	
11M60	17.5" B Width
11M61	21.0" C Width
NIGHT SERVICE KITS	
84W50	Two Stage
HORIZONTAL SUSPENSION KIT	
51W10	80% & 90% Kit
FLUSH MOUNT TERMINATION (90% FURNACES ONLY) US ONLY	
51W11	2" & 3" Vent Version
CONCENTRIC VENT KIT (90% FURNACES ONLY) US ONLY	
71M80	1-1/2" Vent Version
69M29	2" Vent Version
60L46	3" Vent Version
CONCENTRIC VENT KIT (90% FURNACES ONLY) CANADA	
44W92	1-1/2" and 2" Vent Version
44W93	3" Vent Version

For vent length and clearances to combustibles, please reference installation instructions.



1-800-448-5872

All specifications and illustrations subject to change without notice and without incurring obligations.