

INSTALLATION INSTRUCTIONS

A80DF1E & 80G1DFE

Warm Air Gas Furnace
Downflow Air Discharge



This manual must be left with the homeowner for future reference.



This is a safety alert symbol and should never be ignored. When you see this symbol on labels or in manuals, be alert to the potential for personal injury or death.

Table of Contents

Unit Dimensions	2	Duct System	11
Parts Arrangement.....	3	Gas Piping	19
A80DF1E & 80G1DFE Gas Furnace.....	4	Electrical	21
Shipping and Packing List	4	Unit Start-Up.....	25
Safety Information	4	Blower Performance.....	29
General.....	6	Service.....	30
Combustion, Dilution & Ventilation Air	6	Planned Service	32
Setting Equipment	8	Repair Parts List.....	34
Filters.....	11		

WARNING

Improper installation, adjustment, alteration, service or maintenance can cause property damage, personal injury or loss of life. Installation and service must be performed by a licensed professional installer (or equivalent), service agency or the gas supplier.

CAUTION

As with any mechanical equipment, personal injury can result from contact with sharp sheet metal edges. Be careful when you handle this equipment.

Manufactured By
Allied Air Enterprises LLC
A Lennox International, Inc. Company
215 Metropolitan Drive
West Columbia, SC 29170



(P) 507332-01

Save these instructions for future reference

Unit Dimensions

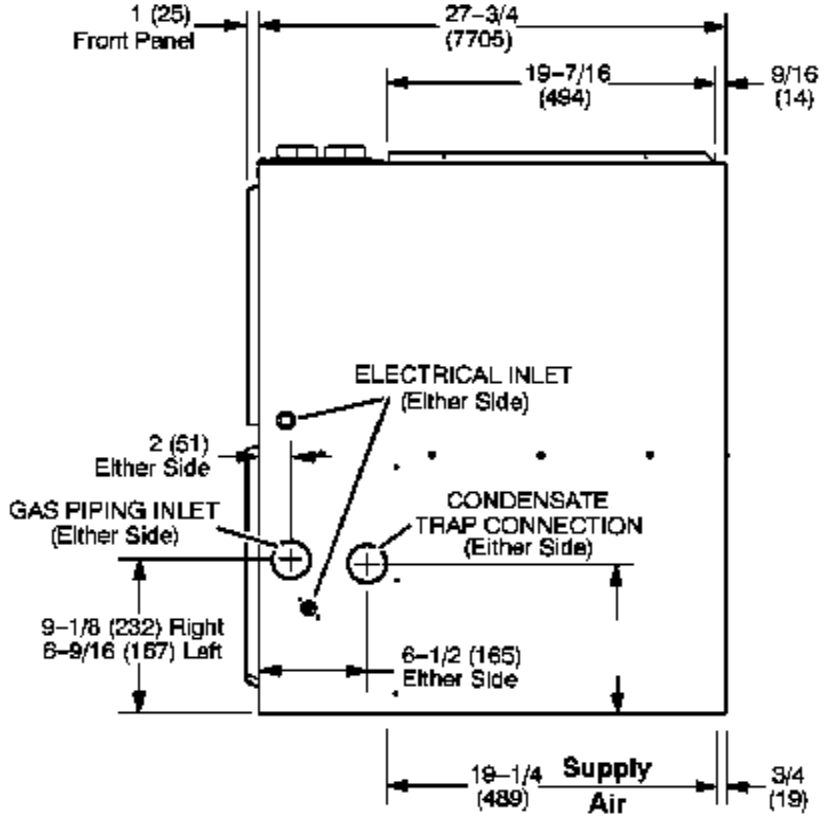
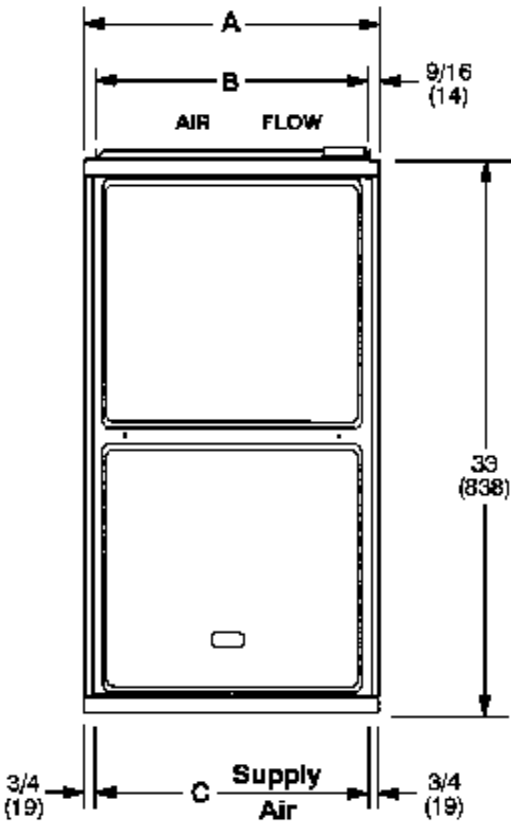
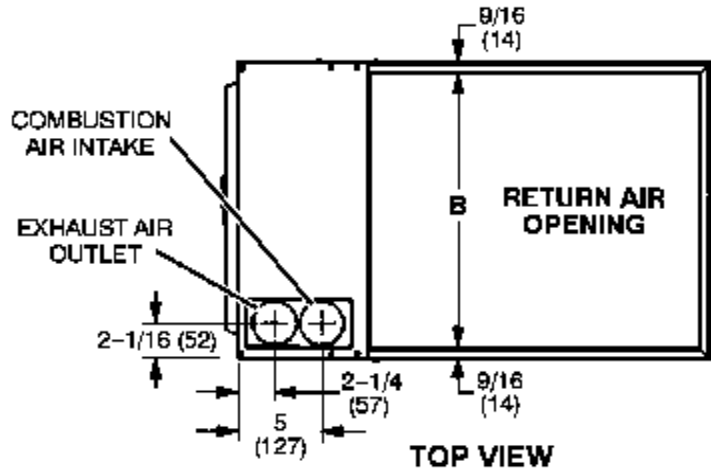

A80DF1E / 80G1DFE Capacity	A		B		C		D	
	in.	mm	in.	mm	in.	mm	in.	mm
045-12 070-12	14-1/2	368	13-3/8	340	13	330	4-3/4	121
090-16	17-1/2	446	16-3/8	416	16	406	6-1/4	159
110-20	21	533	19-7/8	504	19-1/2	495	8	203

Parts Arrangement

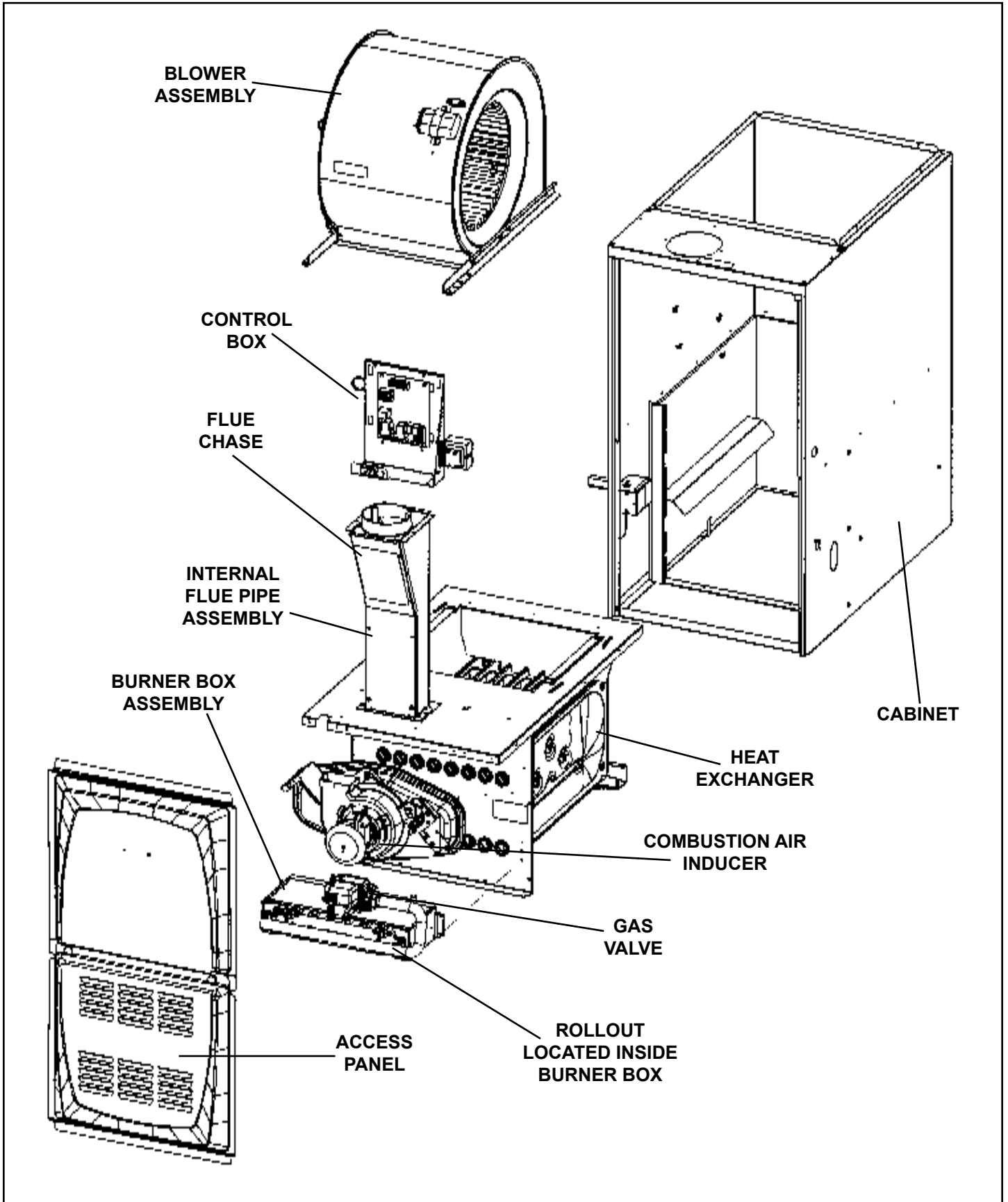

Figure 1.

A80DF1E & 80G1DFE Gas Furnace

The A80DF1E & 80G1DFE gas furnace is shipped ready for installation in the downflow position.

The furnace is equipped for installation in natural gas applications. A conversion kit (ordered separately) is required for use in propane/LP gas applications.

This unit can be installed as either a Direct Vent or a Non-Direct Vent gas central furnace

NOTE: *In Direct Vent installations, combustion air is taken from outdoors and flue gases are discharged outdoors. In Non-Direct Vent installations, combustion air is taken from indoors and flue gases are discharged outdoors.*

Shipping and Packing List

- 1 - Assembled Gas Furnace
- 1 - Bag assembly containing the following:
 - 2 - Screws
 - 3 - Wire nuts
 - 1 - Snap bushing
 - 1 - Snap Plug
 - 1 - Wire tie
 - 1 - Vent warning label
 - 1 - Owner's manual and warranty card

Check equipment for shipping damage. If you find any damage, immediately contact the last carrier.

Please refer to the technical specification sheets for available accessories.

Safety Information

WARNING

DANGER OF EXPLOSION!

There are circumstances in which odorant used with LP/Propane gas can lose its scent. In case of a leak, LP/Propane gas will settle close to the floor and may be difficult to smell. An LP/Propane leak detector should be installed in all LP applications.

Certifications

These units are CSA International certified to ANSI Z21.47.

In the USA, installation of gas furnaces must conform with local building codes. In the absence of local codes, units must be installed according to the current National Fuel Gas Code (ANSI-Z223.1). The National Fuel Gas Code is available from the following address: American National Standards Institute, Inc., 11 West 42nd Street, New York, NY 10036.

Clearances

Adequate clearance must be made around the air openings into the vestibule area. In order to ensure proper unit operation, combustion and ventilation air supply must be provided according to the current National Fuel Gas Code. Vent installations must be consistent with the venting tables (in this instruction) and applicable provisions of local building codes.

This furnace is CSA International certified for installation clearances to combustible material as listed on the unit nameplate and in the tables in Figure 8. Accessibility and service clearances must take precedence over fire protection clearances.

NOTE: *For installation on combustible floors, the furnace shall not be installed directly on carpeting, tile, or other combustible material other than wood flooring.*

Installed Locations

For installation in a residential garage, the furnace must be installed so that the burner(s) and the ignition source are located no less than 18 inches (457 mm) above the floor. The furnace must be located or protected to avoid physical damage by vehicles. When a furnace is installed in a public garage, hangar, or other building that has a hazardous atmosphere, the furnace must be installed according to recommended good practice requirements and current National Fuel Gas Code.

Temperature Rise

NOTE: Furnace must be adjusted to obtain a temperature rise within the range specified on the unit nameplate. Failure to do so may cause erratic limit operation and may result in premature heat exchanger failure.

This furnace must be installed so that its electrical components are protected from water.

Installed in Combination with a Cooling Coil

When this furnace is used with cooling units, it shall be installed in parallel with, or on the upstream side of, cooling units to avoid condensation in the heating compartment. See Figure 2. With a parallel flow arrangement, a damper (or other means to control the flow of air) must adequately prevent chilled air from entering the furnace. If the damper is manually operated, it must be equipped to prevent operation of either the heating or the cooling unit, unless it is in the full HEAT or COOL setting. See Figure 2.

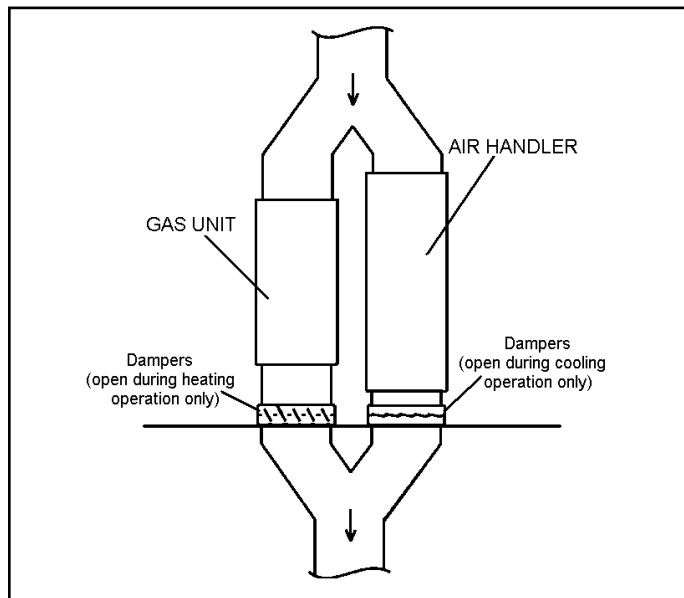

Figure 2. Heating Unit Installed Parallel to Air Handler Unit

When installed, this furnace must be electrically grounded according to local codes. In addition, in the United States, installation must conform with the current National Electric Code, ANSI/NFPA No. 70. The National Electric Code (ANSI/NFPA No. 70) is available from the following address:

National Fire Protection Association
1 Battery March Park
Quincy, MA 02269

NOTE: This furnace is designed for a minimum continuous return air temperature of 60° F (16°C) or an intermittent operation down to 55° F (13°C) dry bulb for cases where a night setback thermostat is used. Return air temperature must not exceed 85° F (29°C) dry bulb.

This furnace may be installed in alcoves, closets, attics, basements, garages, and utility rooms in the upflow or horizontal position.

This furnace design has not been certified for installation in mobile homes, recreational vehicles, or outdoors.

Use of Furnace as a Construction Heater

These units are not recommended for construction heating during any phase of construction. Very low return air temperature, harmful vapors and operation of the unit with clogged or misplaced filters will damage the unit.

These units may be used for heating of buildings or structures under construction, if the following conditions are met:

- The vent system must be permanently installed per these installation instructions.
- A room thermostat must control the furnace. The use of fixed jumpers that will provide continuous heating is not allowed.
- The return air duct must be provided and sealed to the furnace.
- Return air temperature range between 60°F (16°C) and 80°F (27°C) must be maintained.
- Air filters must be installed in the system and must be maintained during construction.
- Air filters must be replaced upon construction completion.
- The input rate and temperature rise must be set per the furnace rating plate.
- One hundred percent (100%) outdoor air must be provided for combustion air requirements during construction. Temporary ducting may supply outdoor air to the furnace. Do not connect duct directly to the furnace. Size the temporary duct following these instructions in section for Combustion, Dilution and Ventilation Air in a confined space with air from outside.
- The furnace heat exchanger, components, duct system, air filters and evaporator coils must be thoroughly cleaned following final construction clean-up.
- All furnace operating conditions (including ignition, input rate, temperature rise and venting) must be verified according to these installation instructions.

General

These instructions are intended as a general guide and do not supersede local codes in any way. Consult authorities having jurisdiction before installation.

In addition to the requirements outlined previously, the following general recommendations must be considered when installing one of these furnaces:

- Place the furnace as close to the center of the air distribution system as possible. The furnace should also be located close to the chimney or vent termination point.
- Do not install the furnace where drafts might blow directly into it. This could cause improper combustion.
- Do not block the furnace combustion air openings with clothing, boxes, doors, etc. Air is needed for proper combustion and safe unit operation.
- When the furnace is installed in an attic or other insulated space, keep insulation away from the furnace.

NOTE: *The Commonwealth of Massachusetts stipulates these additional requirements:*

- Gas furnaces shall be installed by a licensed plumber or fitter only.
- The gas cock must be "T handle" type.
- When a furnace is installed in an attic, the passageway to and service area surrounding the equipment shall be floored.

WARNING

This product contains a chemical known to the State of California to cause cancer, birth defects or other reproductive harm.

Combustion, Dilution & Ventilation Air

In the past, there was no problem in bringing in sufficient outdoor air for combustion. Infiltration provided all the air that was needed. In today's homes, tight construction practices make it necessary to bring in air from outside for combustion. Take into account that exhaust fans, appliance vents, chimneys, and fireplaces force additional air that could be used for combustion out of the house. Unless outside air is brought into the house for combustion, negative pressure (outside pressure is greater than inside pressure) will build to the point that a downdraft can occur in the furnace vent pipe or chimney. As a result, combustion gases enter the living space creating a potentially dangerous situation.

In the absence of local codes concerning air for combustion and ventilation, use the guidelines and procedures in this section to install this furnaces to ensure efficient and safe operation. You must consider combustion air needs and requirements for exhaust vents and gas piping.

A portion of this information has been reprinted with permission from the National Fuel Gas Code (ANSI-Z223.1). This reprinted material is not the complete and official position of the ANSI on the referenced subject, which is represented only by the standard in its entirety.

WARNING

Insufficient combustion air can cause headaches, nausea, dizziness or asphyxiation. It will also cause excess water in the heat exchanger resulting in rusting and premature heat exchanger failure. Excessive exposure to contaminated combustion air will result in safety and performance related problems. Avoid exposure to the following substances in the combustion air supply:

- Permanent wave solutions
- Chlorinated waxes and cleaners
- Chlorine base swimming pool chemicals
- Water softening chemicals
- De-icing salts or chemicals
- Carbon tetrachloride
- Halogen type refrigerants
- Cleaning solvents (such as perchloroethylene)
- Printing inks, paint removers, varnishes, etc.
- Hydrochloric acid
- Antistatic fabric softeners for clothes dryers
- Masonry acid washing materials

All gas fired appliances require air for the combustion process. If sufficient combustion air is not available, the furnace or other appliances will operate inefficiently and unsafely. Enough air must be provided to meet the needs of all fuel-burning appliances and appliances such as exhaust fans which force air out of the house. When fireplaces, exhaust fans, or clothes dryers are used at the same time as the furnace, much more air is necessary to ensure proper combustion and to prevent a downdraft. Insufficient air causes incomplete combustion which can result in carbon monoxide.

In addition to providing combustion air, fresh outdoor air dilutes contaminants in the indoor air. These contaminants may include bleaches, adhesives, detergents, solvents and other contaminants which can corrode furnace components.

The requirements for providing air for combustion and ventilation depend largely on whether the furnace is installed in an unconfined or a confined space.

Unconfined Space

An unconfined space is an area such as a basement or large equipment room with a volume greater than 50 cubic feet (1.42 m³) per 1,000 Btu (.29 kW) per hour of the combined input rating of all appliances installed in that space. This space also includes adjacent rooms which are not separated by a door. Though an area may appear to be unconfined, it might be necessary to bring in outdoor air for combustion if the structure does not provide enough air by infiltration. If the furnace is located in a building of tight construction with weather stripping and caulking around the windows and doors, follow the procedures in the air from outside section.

Confined Space

A confined space is an area with a volume less than 50 cubic feet (1.42 m³) per 1,000 Btu (.29 kW) per hour of the combined input rating of all appliances installed in that space. This definition includes furnace closets or small equipment rooms.

When the furnace is installed so that supply ducts carry air circulated by the furnace to areas outside the space containing the furnace, the return air must be handled by ducts which are sealed to the furnace casing and which terminate outside the space containing the furnace. This is especially important when the furnace is mounted on a platform in a confined space such as a closet or small equipment room. Even a small leak around the base of the unit at the platform or at the return air duct connection can cause a potentially dangerous negative pressure condition. Air for combustion and ventilation can be brought into the confined space either from inside the building or from outside.

Air from Inside

If the confined space that houses the furnace adjoins a space categorized as unconfined, air can be brought in by providing two permanent openings between the two spaces. Each opening must have a minimum free area of 1 square inch (645 mm²) per 1,000 Btu (.29 kW) per hour of total input rating of all gas fired equipment in the confined space. Each opening must be at least 100 square inches (64516 mm²). One opening shall be within 12 inches (305 mm) of the top of the enclosure and one opening within 12 inches (305 mm) of the bottom. See Figure 3.

Air from Outside

If air from outside is brought in for combustion and ventilation, the confined space must have two permanent openings. One opening shall be within 12 inches (305 mm) of the top of the enclosure and one opening within 12 inches (305 mm) of the bottom. These openings must communicate directly or by ducts with the outdoors or spaces (crawl or attic) that freely communicate with the outdoors or indirectly through vertical ducts. Each opening shall have a minimum free area of 1 square inch (645 mm²) per 4,000 Btu (1.17 kW) per hour of total input rating of all equipment in the enclosure. See Figure 4 and Figure 5. When communicating with the outdoors through horizontal ducts, each opening shall have a minimum free area of 1 square inch (645 mm²) per 2,000 Btu (.56 kW) per total input rating of all equipment in the enclosure. See Figure 6.

When ducts are used, they shall be of the same cross sectional area as the free area of the openings to which they connect. The minimum dimension of rectangular air ducts shall be no less than 3 inches (75 mm). In calculating free area, the blocking effect of louvers, grilles, or screens must be considered. If the design and free area of protective covering is not known for calculating the size opening required, it may be assumed that wood louvers will have 20 to 25 percent free area and metal louvers and grilles will have 60 to 75 percent free area. Louvers and grilles must be fixed in the open position or interlocked with the equipment so that they are opened automatically during equipment operation.

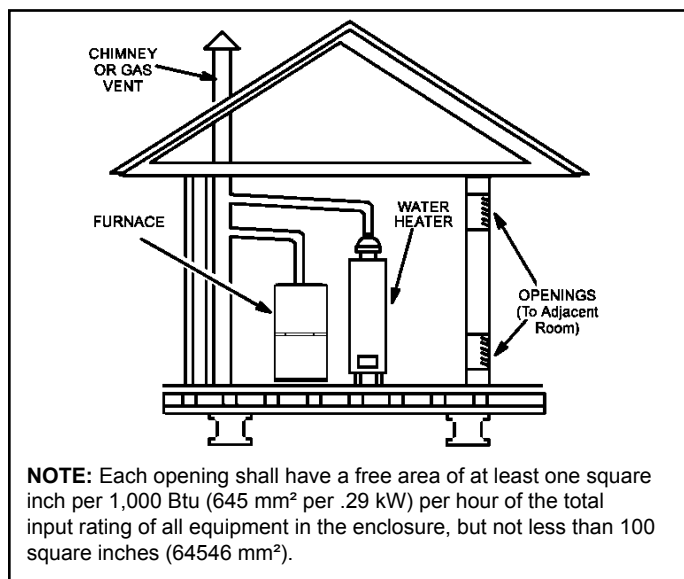

Figure 3. Equipment in Confined Space - All Air From Inside

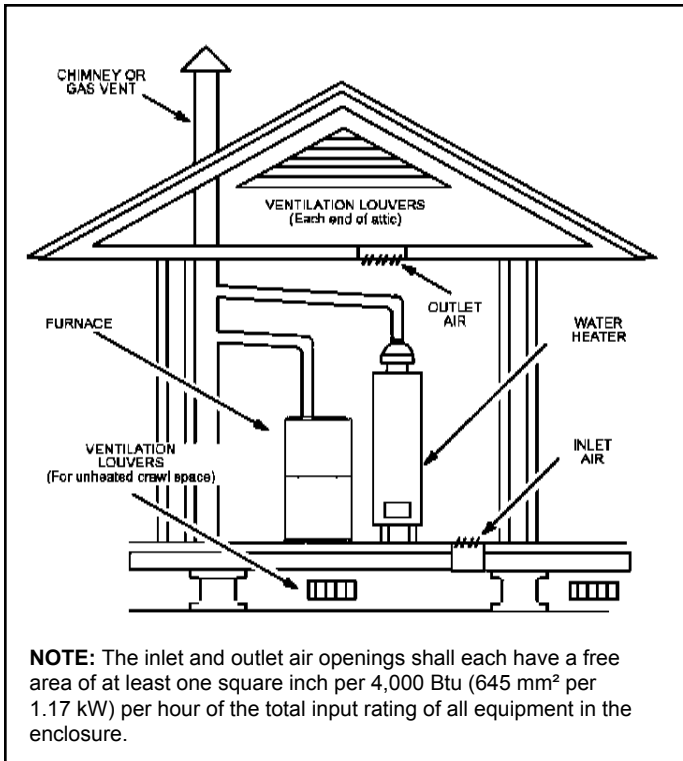

Figure 4. Equipment in Confined Space - All Air from Outside
(Inlet Air from Crawlspace & Outlet Air to Ventilated Attic)

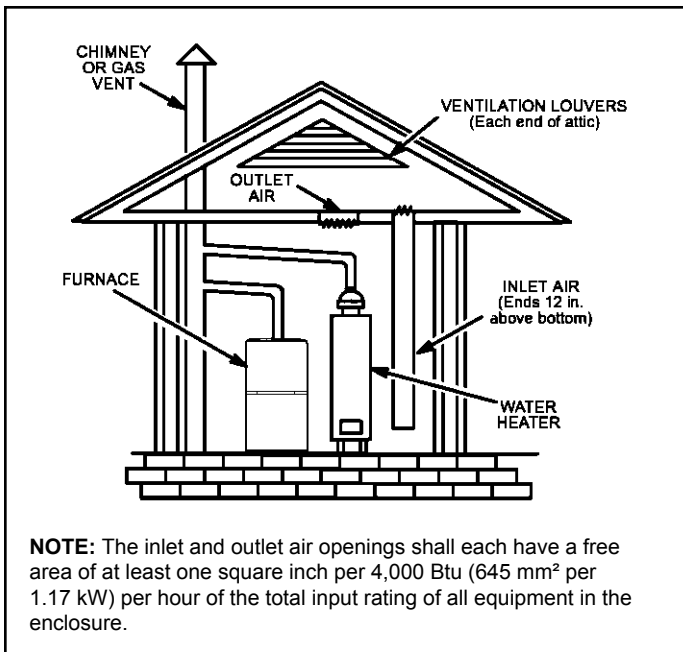

Figure 5. Equipment in Confined Space - All Air from Outside
(All Air through Ventilated Attic)

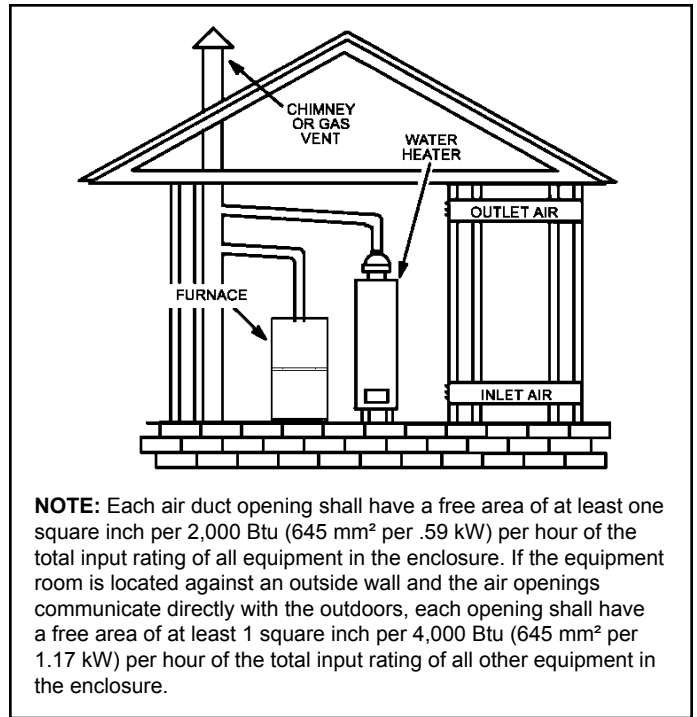

Figure 6. Equipment in Confined Space - All Air from Outside

Setting Equipment

⚠ WARNING

Do not install the furnace on its front or its back. Do not connect the return air ducts to the back of the furnace. Doing so will adversely affect the operation of the safety control devices, which could result in personal injury or death.

Select a location that allows for the required clearances that are listed on the unit nameplate. Also consider gas supply connections, electrical supply, vent connection, and installation and service clearances [24 inches (610 mm) at unit front]. The unit must be level.

NOTE: Units with 1/2 hp & 3/4 hp blower motors are equipped with three flexible legs and one rigid leg. See Figure 7. The rigid leg is equipped with a shipping bolt and a flat white plastic washer (rather than the rubber mounting grommet used with a flexible mounting leg). The bolt and washer must be removed before the furnace is placed into operation. After the bolt and washer have been removed, the rigid leg will not touch the blower housing.

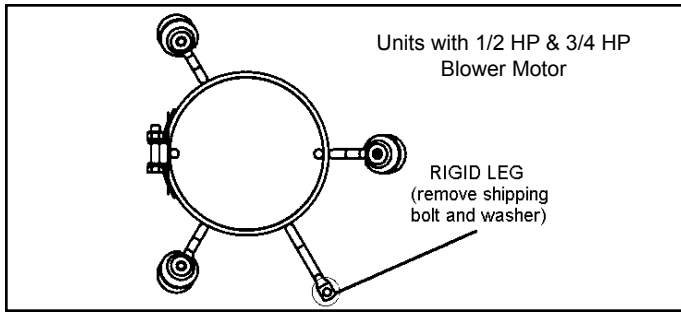

Figure 7.

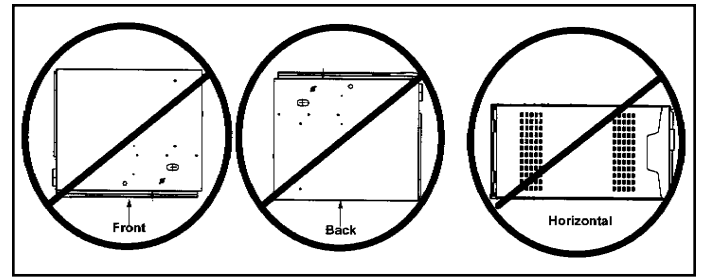

Figure 9.

Downflow Applications

Allow for clearances to combustible materials as indicated on the unit nameplate. Minimum clearances for closet or alcove installations are shown in Figure 8.

Type of Vent Connector	Type C	Type B ¹
Top	1 in. (25 mm)	1 in. (25 mm)
*Front	2-1/4 in. (57 mm)	2-1/4 in. (57 mm)
Back	0	0
Sides	0†	0
Vent	6 in. (152 mm)	1 in. (25 mm)
Floor	0‡	0‡

* Front clearance in alcove installation must be 24 in. (610 mm). Maintain a minimum of 24 in. (610 mm) for front service access.

‡ For installation on a combustible floor, do not install the furnace directly on carpeting, tile or other combustible materials other than wood flooring.

† Left side requires 3 in. if a single wall vent is used on 14-1/2 in. cabinets.

Figure 8. Downflow Application Installation Clearances

Return Air

Return air must be brought in through the top of the furnace installed in an downflow application.

⚠ WARNING

Improper installation of the furnace can result in personal injury or death. Combustion and flue products must never be allowed to enter the return air system or air in the living space. Use sheet metal screws and joint tape to seal return air system to furnace.

In platform installations with furnace return, the furnace should be sealed airtight to the return air plenum. A door must never be used as a portion of the return air duct system. The base must provide a stable support and an airtight seal to the furnace. Allow absolutely no sagging, cracks, gaps, etc.

For no reason should return and supply air duct systems ever be connected to or from other heating devices such as a fireplace or stove, etc. Fire, explosion, carbon monoxide poisoning, personal injury and/or property damage could result.

Installation on Non-Combustible Flooring

See Figure 10

1. Cut floor opening keeping in mind clearances listed on unit rating plate. Also keep in mind gas supply connections, electrical supply, flue and air intake connections and sufficient installation and servicing clearances. See Table 1 for correct floor opening size.
2. Flange warm air plenum and lower the plenum into the opening.
3. Set the unit over the plenum and seal the plenum to the unit.
4. Ensure that the seal is adequate.

Cabinet Width	Front to Rear		Side to Side	
	in.	mm	in.	mm
B Cabinet (17.5")	19-3/4	502	16-5/8	422
C Cabinet (21")			20-1/8	511

NOTE: Floor opening dimensions listed are 1/4 in. (6 mm) larger than the unit opening. See dimension drawing on Page 2.

Table 1. Non-Combustible Floor Opening Size

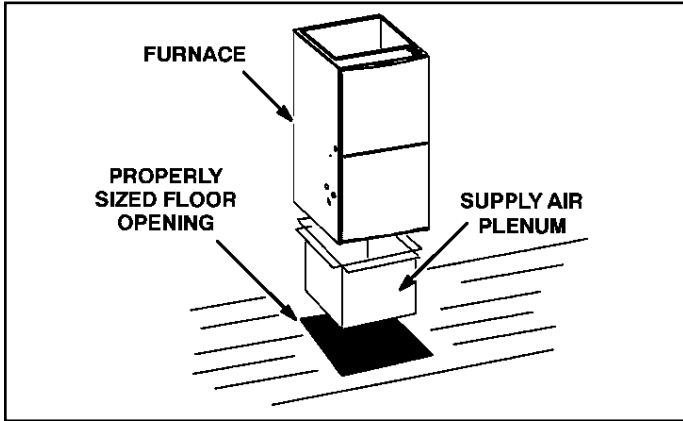

Figure 10.

Installation on Combustible Flooring

See Figure 11

1. When unit is installed on a combustible floor, a downflow combustible flooring base must be installed between the furnace and the floor. The base must be ordered separately. See Table 2 for opening size to cut in floor.

⚠ CAUTION

The furnace and combustible flooring base shall not be installed directly on carpeting, tile, or other combustible material other than wood flooring.

Cabinet Width	Catalog Number	Front to Rear		Side to Side	
		in.	mm	in.	mm
B Cabinet (17.5")	11M60	22	559	18-3/4	476
C Cabinet (21")				22-3/4	578

Table 2. Combustible Flooring Base Opening Size

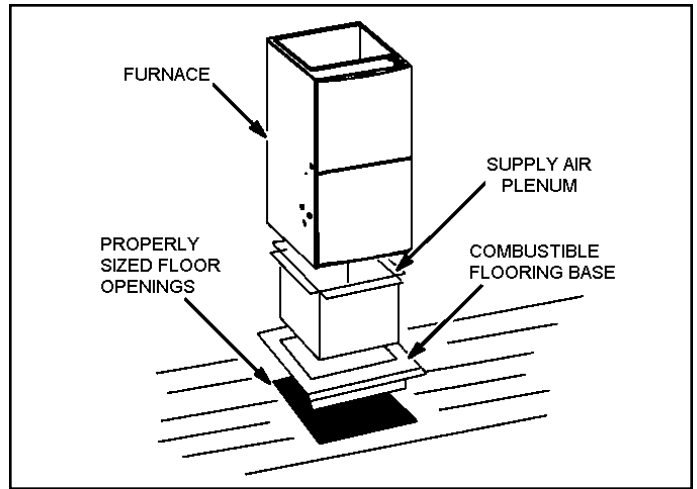

Figure 11.

2. After opening is cut, set the combustible flooring base into opening.
 3. Check fiberglass strips on the combustible flooring base to make sure they are properly glued and positioned.
 4. Lower supply air plenum into the combustible flooring base until plenum flanges seal against fiberglass strips.
- NOTE:** Be careful not to damage fiberglass strips. Check for a tight seal.
5. Set the furnace over the plenum.
 6. Ensure that the seal between the furnace and plenum is adequate.

Installation on Cooling Coil Cabinet

See Figure 12

NOTE: Downflow combustible flooring kit is not used.

1. Refer to reverse flow coil installation instructions for correctly sized opening in floor and installation of cabinet.
2. When cooling cabinet is in place, set and secure the furnace according to the instructions that are provided with the cooling coil. Secure the furnace to the cabinet.
3. Seal the cabinet and check for air leaks.

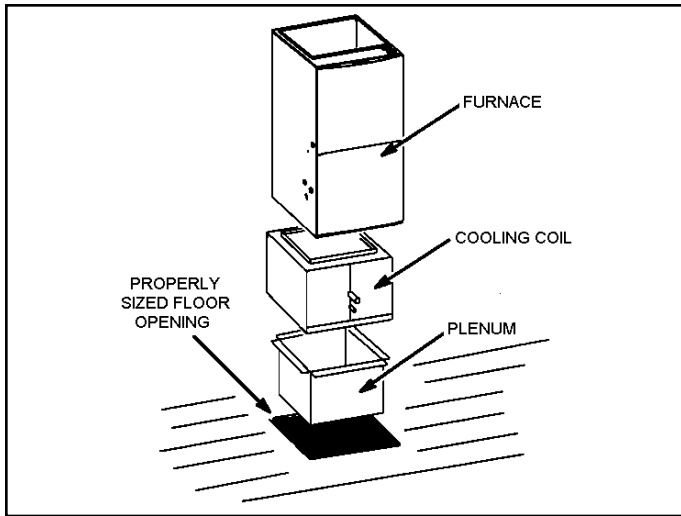

Figure 12.

Return Air Opening - Downflow Units

Return air may be brought in only through the top opening of a furnace installed in the downflow position. The following steps should be taken when installing plenum:

1. Bottom edge of plenum should be flanged with a hemmed edge (see Figure 13 or Figure 14).
2. Sealing strips should be used to ensure an airtight seal between the cabinet and the plenum.
3. In all cases, plenum should be secured to top of furnace using sheet metal screws.
4. Make certain that an adequate seal is made.

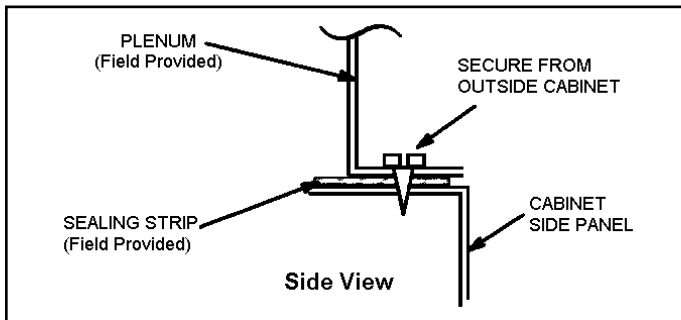

Figure 13.

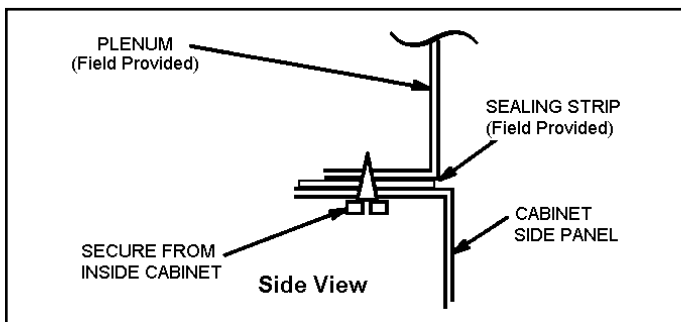

Figure 14.

Filters

This unit is not equipped with a filter or rack. A field provided high velocity filter is required for the unit to operate properly.

A filter must be in place any time the unit is operating.

Duct System

Use industry approved standards (such as those published by Air Conditioning Contractors of America or American Society of Heating, Refrigerating and Air Conditioning Engineers) to size and install the supply and return air duct system. This will result in a quiet and low static system that has uniform air distribution.

NOTE: Do not operate the furnace in the heating mode with an external static pressure that exceeds 0.8 inches w.c. Higher external static pressures may cause erratic limit operation.

Supply Air Plenum

If the furnace is installed without a cooling coil, a removable access panel must be installed in the supply air duct. The access panel should be large enough to permit inspection (either by smoke or reflected light) of the heat exchanger for leaks after the furnace is installed. The furnace access panel must always be in place when the furnace is operating and it must not allow leaks into the supply air duct system.

Return Air Plenum

NOTE: Return air must not be drawn from a room where this furnace, or any other gas fueled appliance (i.e., water heater), or carbon monoxide producing device (i.e., wood fireplace) is installed.

When return air is drawn from a room, a negative pressure is created in the room. If a gas appliance is operating in a room with negative pressure, the flue products can be pulled back down the vent pipe and into the room. This reverse flow of the flue gas may result in incomplete combustion and the formation of carbon monoxide gas. This toxic gas might then be distributed throughout the house by the furnace duct system.

Venting

A 4 inch diameter flue transition is factory installed on the combustion air inducer outlet of all models.

⚠ IMPORTANT

The unit will not vent properly with the flue transition pointed down in the 6 o'clock position.

The combustion air inducer may be rotated clockwise or counterclockwise by 90° to allow for top or side vent discharge in all applications. When the unit is installed, the flue transition must be in the 9 o'clock, 12 o'clock or 6 o'clock position.

These series units are classified as fan assisted Category I furnaces when vertically vented according to the latest edition of National Fuel Gas Code (NFPA 54 / ANSI Z223.1) in the USA. A fan assisted Category I furnace is an appliance equipped with an integral mechanical means to either draw or force combustion products through the combustion chamber and/or heat exchanger. This unit is not approved for use with horizontal venting.

NOTE: Use these instructions as a guide. They do not supersede local codes. This furnace must be vented according to all local codes these installation instructions, and the provided venting tables in these instructions.

The venting tables in this manual were extracted from the National Fuel Gas Code (NFPA 54 / ANSI Z223.1) and are provided as a guide for proper vent installation. Proper application, termination, construction and location of vents must conform to local codes having jurisdiction. In the absence of local codes, the NFGC serves as the defining document.

Refer to the tables and the venting information contained in these instructions to properly size and install the venting system.

⚠ IMPORTANT

Once the venting system is installed, attach the "Disconnected Vent" warning sticker to a visible area of the plenum near the vent pipe. See Figure 15. The warning sticker is provided in the bag assembly. Order kit 66W04 for additional stickers.

⚠ WARNING

Asphyxiation hazard. The exhaust vent for this furnace must be securely connected to the furnace flue transition at all times.

Use self drilling sheet metal screws or a mechanical fastener to firmly secure the vent pipe to the round collar of the flue transition. If self drilling screws are used to attach the vent pipe, it is recommended that three be used. Drive

one self drilling screw through the front and one through each side of the vent pipe and collar. See Figure 15.

Install the first vent connector elbow at a minimum of six inches (152 mm) from the furnace vent outlet. See Figure 15.

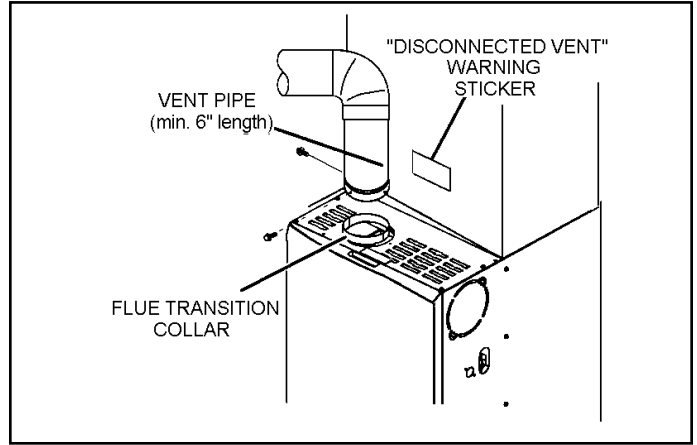

Figure 15. Vent Connection

Venting Using a Masonry Chimney

The following additional requirements apply when a lined masonry chimney is used to vent this furnace.

Masonry chimneys used to vent Category I central furnaces must be either tile lined or lined with a listed metal lining system or dedicated gas vent. Unlined masonry chimneys are prohibited. See Figure 16 and Figure 17 for common venting.

A chimney with one or more sides exposed to the outside of the structure is considered to be an exterior chimney.

An exterior masonry chimney that is not tile lined must be lined with B 1 vent or a listed insulated flexible metal vent. An exterior tile lined chimney that is sealed and capped may be lined with a listed uninsulated flexible metal vent.

If the existing chimney will not accommodate a listed metal liner, either the chimney must be rebuilt to accommodate one of these liners or an alternate approved venting method must be found.

Insulation for the flexible vent pipe must be an encapsulated fiberglass sleeve recommended by the flexible vent pipe manufacturer.

⚠ IMPORTANT

SINGLE appliance venting of a fan assisted furnace into a tile lined masonry chimney (interior or outside wall) is prohibited. The chimney must first be lined with either type B1 vent or an insulated single wall flexible vent lining system which has been sized according to the provided venting tables and the vent pipe manufacturer's instructions.

DO NOT insulate the space between the liner and the chimney wall with puffed mica or any other loose granular insulating material.

terminate above the roof surface with a listed cap or a listed roof assembly according to the terms of their respective listings and the vent manufacturer's instructions.

When inspection reveals that an existing chimney is not safe for the intended purpose, it shall be rebuilt to conform to nationally recognized standards, lined or relined with suitable materials, or replaced with a gas vent or chimney suitable for venting. The chimney passageway must be checked periodically to ensure that it is clear and free of obstructions.

Do not install a manual damper, barometric draft regulator, or flue restrictor between the furnace and the chimney.

Never connect a Category I appliance to a chimney that is servicing a solid fuel appliance. If a fireplace chimney flue is used to vent this appliance, the fireplace opening must be permanently sealed.

A type B or listed chimney lining system that passes through an unused masonry chimney flue is not considered to be exposed to the outdoors.

General Venting Requirements

Vent all furnaces according to these instructions:

1. Vent diameter recommendations and maximum allowable piping runs are found in the provided venting tables.
2. In no case should the vent or vent connector diameter be less than the diameter specified in the provided venting tables.
3. The minimum vent capacity determined by the sizing tables must be less than the low fire input rating and the maximum vent capacity must be greater than the high fire input rating.
4. Single appliance vents - If the vertical vent or tile lined chimney has a larger diameter or flow area than the vent connector, use the vertical vent diameter to

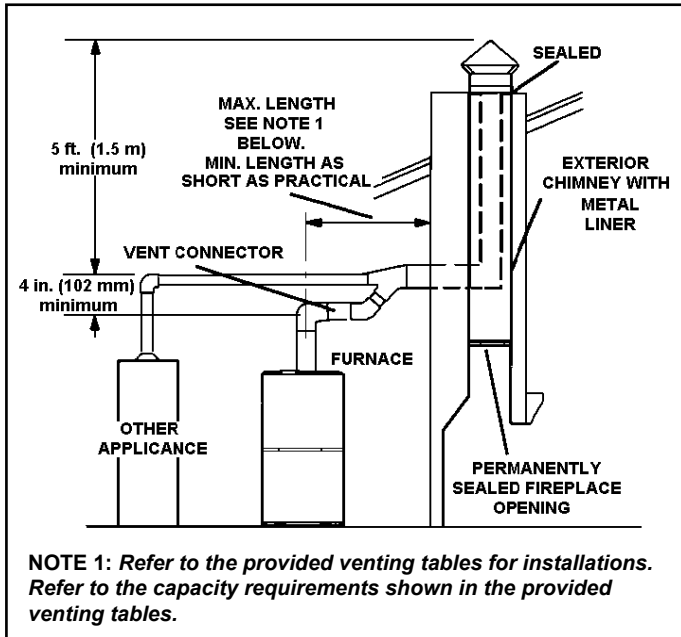

Figure 16. Common Venting Using Metal-Lined Masonry Chimney

A fan assisted furnace may be commonly vented into an existing lined masonry chimney if the following conditions are met:

- The chimney is currently serving at least one drafthood equipped appliance.
- The vent connectors and chimney are sized according to the provided venting tables.

If type B1 double wall vent is used inside a chimney, no other appliance can be vented into the chimney. The outer wall of type B1 vent pipe must not be exposed to flue products. A type B1 vent or masonry chimney liner shall

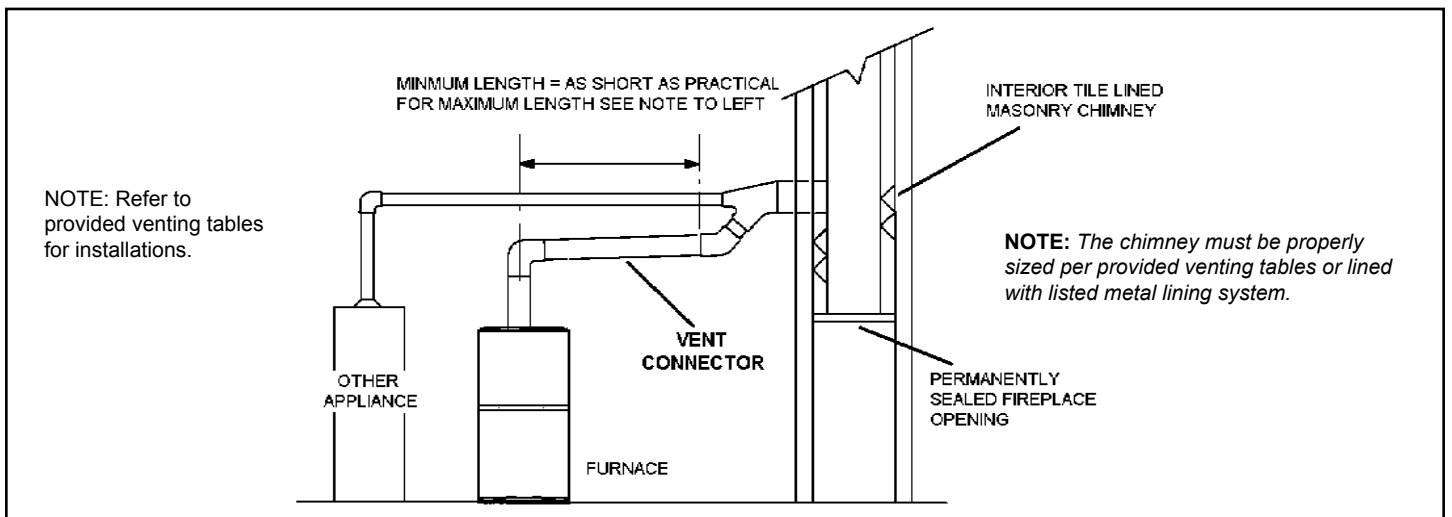

Figure 17. Common Venting Using Tile Lined Interior Masonry Chimney and Combined Vent Connector

determine the minimum vent capacity and the vent connector diameter to determine the maximum vent capacity. The flow area of the vertical vent, however, shall not exceed 7 times the flow area of the listed appliance categorized vent area, draft hood outlet area or flue collar area unless designed according to approved engineering methods.

5. Multiple appliance vents - The flow area of the largest section of vertical vent or chimney shall not exceed 7 times the smallest listed appliance categorized vent area, draft hood outlet area or flue collar area unless designed according to approved engineering methods.
6. The entire length of single wall metal vent connector shall be readily accessible for inspection, cleaning, and replacement.
7. Single appliance venting configurations with zero lateral lengths (Table 4 and Table 5) are assumed to have no elbows in the vent system. For all other vent configurations, the vent system is assumed to have two 90° elbows. For each additional 90° elbow or equivalent (for example two 45° elbows equal one 90° elbow) beyond two, the maximum capacity listed in the venting table should be reduced by 10% (0.90 x maximum listed capacity).
8. The common venting tables (6, 7, 8, and 9) were generated using a maximum horizontal vent connector length of 1-1/2 feet (.46 m) for each inch (25 mm) of connector diameter as follows:

Connector Diameter inches (mm)	Maximum Horizontal Connector Length feet (m)
3 (76)	4-1/2 (1.37)
4 (102)	6 (1.83)
5 (127)	7-1/2 (2.29)
6 (152)	9 (2.74)
7 (178)	10-1/2 (3.20)

Table 3.

9. If the common vertical vent is offset, the maximum common vent capacity listed in the common venting tables should be reduced by 20%, the equivalent of two 90° elbows (0.80 x maximum common vent capacity). The horizontal length of the offset shall not exceed 1-1/2 feet (.46 m) for each inch (25 mm) of common vent diameter.
10. The vent pipe should be as short as possible with the least number of elbows and angles required to complete the job. Route the vent connector to the vent using the shortest possible route.

11. A vent connector shall be supported without any dips or sags and shall slope a minimum of 1/4 inch (6.4 mm) per linear foot (305 mm) of connector, back toward the appliance.
12. Vent connectors shall be firmly attached to the furnace flue collar by self drilling screws or other approved means, except vent connectors of listed type B1 vent material which shall be assembled according to the manufacturer's instructions. Joints between sections of single wall connector piping shall be fastened by screws or other approved means.
13. When the vent connector used for Category I appliances must be located in or pass through a crawl space, attic or other areas which may be cold, that portion of the vent connector shall be constructed of listed doublewall type B1 vent material or material having equivalent insulation qualities.
14. All venting pipe passing through floors, walls, and ceilings must be installed with the listed clearance to combustible materials and be fire stopped according to local codes. In absence of local codes, refer to NFGC (2223.1).
15. No portion of the venting system can extend into, or pass through any circulation air duct or plenum.
16. Vent connectors serving Category I appliances shall not be connected to any portion of mechanical draft systems operating under positive pressure such as Category III or IV venting systems.
17. If vent connectors are combined prior to entering the common vent, the maximum common vent capacity listed in the common venting tables must be reduced by 10%, the equivalent of one 90° elbow (0.90 x maximum common vent capacity).
18. The common vent diameter must always be at least as large as the largest vent connector diameter.
19. In no case, shall the vent connector be sized more than two consecutive table size diameters over the size of the draft hood outlet or flue collar outlet.
20. Do not install a manual damper, barometric draft regulator or flue restrictor between the furnace and the chimney.
21. When connecting this appliance to an existing dedicated or common venting system, you must inspect the venting system's general condition and look for signs of corrosion. The existing vent pipe size must conform to these instructions and the provided venting tables. If the existing venting system does not meet these requirements, it must be resized.

Capacity of Type B Double Wall Vents with Type B Double Wall Connectors Serving a Single Category I Appliance

Height H (feet)	Lateral L (feet)	Vent and Connector Diameter - D (inches)							
		3 inch		4 inch		5 inch		6 inch	
		Appliance Input Rating in Thousands of Btu per Hour							
		MIN	MAX	MIN	MAX	MIN	MAX	MIN	MAX
6	0	0	78	0	152	0	251	0	375
	2	13	51	18	97	27	157	32	232
	4	21	49	30	94	39	153	50	227
	6	25	46	36	91	47	149	59	223
8	0	0	84	0	165	0	276	0	415
	2	12	57	16	109	25	178	28	263
	5	23	53	32	103	42	171	53	255
	8	28	49	39	98	51	164	64	247
10	0	0	88	0	175	0	295	0	447
	2	12	61	17	118	23	194	26	289
	5	23	57	32	113	41	187	52	280
	10	30	51	41	104	54	176	67	267
15	0	0	94	0	191	0	327	0	502
	2	11	69	15	136	20	226	22	339
	5	22	65	30	130	39	219	49	330
	10	29	59	40	121	51	206	64	315
	15	35	53	48	112	61	195	76	301
20	0	0	97	0	202	0	349	0	540
	2	10	75	14	149	18	250	20	377
	5	21	71	29	143	38	242	47	367
	10	28	64	38	133	50	229	62	351
	15	34	58	46	124	59	217	73	337
	20	48	52	55	116	69	206	84	322
30	0	0	100	0	213	0	374	0	587
	2	9	81	13	166	14	283	18	432
	5	21	77	28	160	36	275	45	421
	10	27	70	37	150	48	262	59	405
	15	33	64	44	141	57	249	70	389
	20	56	58	53	132	66	237	80	374
	30	NR	NR	73	113	88	214	104	346

NOTE: Single appliance venting configurations with zero lateral lengths are assumed to have no elbows in the vent system. For all other vent configurations, the vent system is assumed to have two 90° elbows. For each additional 90° elbow or equivalent (for example two 45° elbows equal one 90° elbow) beyond two, the maximum capacity listed in the venting table should be reduced by 10 percent (0.90 x maximum listed capacity).

Table 4.

Capacity of Type B Double Wall Vents with Single Wall Metal Connectors Serving a Single Category I Appliance

Height H (feet)	Lateral L (feet)	Vent and Connector Diameter - D (inches)							
		3 inch		4 inch		5 inch		6 inch	
		Appliance Input Rating in Thousands of Btu per Hour							
		MIN	MAX	MIN	MAX	MIN	MAX	MIN	MAX
6	0	38	77	59	151	85	243	126	373
	2	39	51	60	96	85	158	123	231
	4	NR	NR	74	92	102	152	146	225
	6	NR	NR	83	89	114	147	163	220
8	0	37	83	68	164	83	273	123	412
	2	39	56	59	108	83	176	121	261
	5	NR	NR	77	102	107	188	151	252
	8	NR	NR	90	95	122	161	175	243
10	0	37	67	57	174	82	293	120	444
	2	39	61	59	117	82	193	119	287
	5	52	56	76	111	105	185	148	277
	10	NR	NR	97	100	132	171	188	261
15	0	36	93	56	190	60	325	116	499
	2	38	69	57	136	80	225	115	337
	5	51	63	75	128	102	216	144	326
	10	NR	NR	95	116	128	201	182	308
	15	NR	NR	NR	NR	158	186	220	290
20	0	35	96	54	200	78	346	114	537
	2	37	74	56	148	78	248	113	375
	5	50	68	73	140	100	239	141	363
	10	NR	NR	93	129	125	223	177	344
	15	NR	NR	NR	NR	155	208	216	325
	20	NR	NR	NR	NR	186	192	254	306
30	0	34	99	53	211	76	372	110	584
	2	37	80	55	164	76	281	109	429
	5	49	74	72	157	98	271	136	417
	10	NR	NR	91	144	122	255	171	397
	15	NR	NR	115	131	151	239	208	377
	20	NR	NR	NR	NR	181	223	246	357
	30	NR	NR	NR	NR	NR	NR	NR	NR

NOTE: Single appliance venting configurations with zero lateral lengths are assumed to have no elbows in the vent system. For all other vent configurations, the vent system is assumed to have two 90° elbows. For each additional 90° elbow or equivalent (for example two 45° elbows equal one 90° elbow) beyond two, the maximum capacity listed in the venting table should be reduced by 10 percent (0.90 x maximum listed capacity).

Table 5.

Vent Connector Capacity
Type B Double Wall Vents with Type B Double Wall Connectors Serving Two or More Category I Appliances

Vent Height H (feet)	Connector Rise R (feet)	Vent and Connector Diameter - D (inches)							
		3 inch		4 inch		5 inch		6 inch	
		Appliance Input Rating in Thousands of Btu per Hour							
		MIN	MAX	MIN	MAX	MIN	MAX	MIN	MAX
6	1	22	37	35	66	46	106	58	164
	2	23	41	37	75	48	121	60	183
	3	24	44	38	81	49	132	62	199
8	1	22	40	35	72	49	114	64	176
	2	23	44	36	80	51	128	66	195
	3	24	47	37	67	53	139	67	210
10	1	22	43	34	78	49	123	65	189
	2	23	47	36	86	51	136	67	206
	3	24	50	37	92	52	146	69	220
15	1	21	50	33	89	47	142	64	220
	2	22	53	35	96	49	153	66	235
	3	24	55	36	102	51	163	68	248
20	1	21	54	33	99	46	157	62	246
	2	22	57	34	105	48	167	64	259
	3	23	60	35	110	50	176	66	271
30	1	20	62	31	113	45	181	60	288
	2	21	64	33	118	47	190	62	299
	3	22	66	34	123	48	198	64	309

Table 6.

Common Vent Capacity
Type B Double Wall Vents with Type B Double Wall Connectors Serving Two or More Category I Appliances

Vent Height H (feet)	Common Vent Diameter - D (inches)							
	4 inch		5 inch		6 inch		7 inch	
	Appliance Input Rating in Thousands of Btu per Hour							
	FAN + FAN	FAN + NAT	FAN + FAN	FAN + NAT	FAN + FAN	FAN + NAT	FAN + FAN	FAN + NAT
6	92	81	140	116	204	161	309	248
8	101	90	155	129	224	178	339	275
10	110	97	169	141	243	194	367	299
15	125	112	195	164	283	228	427	352
20	136	123	215	183	314	255	475	394
30	152	138	244	210	361	297	547	459

Table 7.

Vent Connector Capacity
Type B Double Wall Vents with Single Wall Metal Connectors Serving Two or More Category I Appliances

Vent Height H (feet)	Connector Rise R (feet)	Vent and Connector Diameter - D (inches)							
		3 inch		4 inch		5 inch		6 inch	
		Appliance Input Rating in Thousands of Btu per Hour							
		MIN	MAX	MIN	MAX	MIN	MAX	MIN	MAX
6	1	NR	NR	NR	NR	NR	NR	NR	NR
	2	NR	NR	NR	NR	NR	NR	168	182
	3	NR	NR	NR	NR	121	131	175	198
8	1	NR	NR	NR	NR	NR	NR	NR	NR
	2	NR	NR	NR	NR	125	126	184	193
	3	NR	NR	NR	NR	130	138	191	208
10	1	NR	NR	NR	NR	119	121	182	186
	2	NR	NR	84	85	124	134	189	203
	3	NR	NR	89	91	129	144	197	217
15	1	NR	NR	79	87	116	138	177	214
	2	NR	NR	83	94	121	150	185	230
	3	NR	NR	87	100	127	160	193	243
20	1	49	56	78	97	115	152	175	238
	2	52	59	82	103	120	163	182	252
	3	55	62	87	107	125	172	190	264
30	1	47	60	77	110	112	175	169	278
	2	51	62	81	115	117	185	177	290
	3	54	64	85	119	122	193	185	300

NOTE: Single appliance venting configurations with zero lateral lengths are assumed to have no elbows in the vent system. For all other vent configurations, the vent system is assumed to have two 90° elbows. For each additional 90° elbow or equivalent (for example two 45° elbows equal one 90° elbow) beyond two, the maximum capacity listed in the venting table should be reduced by 10 percent (0.90 x maximum listed capacity).

Table 8.

Common Vent Capacity
Type B Double Wall Vents with Single Wall Metal Connectors Serving Two or More Category I Appliances

Vent Height H (feet)	Common Vent Diameter - D (inches)							
	4 inch		5 inch		6 inch		7 inch	
	Appliance Input Rating in Thousands of Btu per Hour							
	FAN + FAN	FAN + NAT	FAN + FAN	FAN + NAT	FAN + FAN	FAN + NAT	FAN + FAN	FAN + NAT
6	N/A	78	N/A	113	200	158	304	244
8	N/A	87	N/A	126	218	173	331	269
10	N/A	94	163	137	237	189	357	292
15	121	108	189	159	275	221	416	343
20	131	118	208	177	305	247	463	383
30	145	132	236	202	350	286	533	446

Table 9.

Removal of the Furnace from Common Vent

In the event that an existing furnace is removed from a venting system commonly run with separate gas appliances, the venting system is likely to be too large to properly vent the remaining attached appliances.

Conduct the following test while each appliance is operating and the other appliances (which are not operating) remain connected to the common venting system. If the venting system has been installed improperly, you must correct the system as indicated in the general venting requirements section.

WARNING

CARBON MONOXIDE POISONING HAZARD

Failure to follow the steps outlined below for each appliance connected to the venting system being placed into operation could result in carbon monoxide poisoning or death.

The following steps shall be followed for each appliance connected to the venting system being placed into operation, while all other appliances connected to the venting system are not in operation:

1. Seal any unused openings in the common venting system.
2. Inspect the venting system for proper size and horizontal pitch. Determine that there is no blockage, restriction, leakage, corrosion, or other deficiencies which could cause an unsafe condition.
3. Close all building doors and windows and all doors between the space in which the appliances remaining connected to the common venting system are located and other spaces of the building. Turn on clothes dryers and any appliances not connected to the common venting system. Turn on any exhaust fans, such as range hoods and bathroom exhausts, so they will operate at maximum speed. Do not operate a summer exhaust fan. Close fireplace dampers.
4. Follow the lighting instructions. Turn on the appliance that is being inspected. Adjust the thermostat so that the appliance operates continuously.
5. After the burners have operated for 5 minutes, test for leaks of flue gases at the draft hood relief opening. Use the flame of a match or candle.
6. After determining that each appliance connected to the common venting system is venting properly, (step 3) return all doors, windows, exhaust fans, fireplace dampers, and any other gas burning appliances to their previous mode of operation.
7. If a venting problem is found during any of the preceding tests, the common venting system must be modified to correct the problem.

Resize the common venting system to the minimum vent pipe size determined by using the appropriate tables in Appendix G. (These are in the current standards of the National Fuel Gas Code ANSI Z223.1.

Gas Piping

CAUTION

If a flexible gas connector is required or allowed by the authority that has jurisdiction, black iron pipe shall be installed at the gas valve and extend outside the furnace cabinet. The flexible connector can then be added between the black iron pipe and the gas supply line.

Gas Supply

1. This unit is shipped standard for left or right side installation of gas piping (or top entry in horizontal applications). Connect the gas supply to the piping assembly.
2. When connecting the gas supply piping, consider factors such as length of run, number of fittings, and furnace rating to avoid excessive pressure drop. Table 10 lists recommended pipe sizes for typical applications.
3. The gas piping must not run in or through air ducts, clothes chutes, gas vents or chimneys, dumb waiters, or elevator shafts.
4. The piping should be sloped 1/4 inch (6.4 mm) per 15 feet (4.57 m) upward toward the meter from the furnace. The piping must be supported at proper intervals [every 8 to 10 feet (2.44 to 3.01 m)] with suitable hangers or straps. Install a drip leg in vertical pipe runs to the unit.
5. A 1/8" N.P.T. plugged tap or pressure post is located on the gas valve to facilitate test gauge connection. See Figure 19.
6. In some localities, codes may require the installation of a manual main shut off valve and union (furnished by the installer) external to the unit. The union must be of the ground joint type.

IMPORTANT

Compounds used on threaded joints of gas piping must be resistant to the actions of liquified petroleum gases.

NOTE: *If emergency shutoff is necessary, shut off the main manual gas valve and disconnect main power to the furnace. The installer should properly label these devices.*

Gas Pipe Capacity - FT³/HR (kL/HR)

Nominal Iron Pipe Size - inches (mm)	Internal Diameter - inches (mm)	Length of Pipe - feet (m)									
		10 (3.048)	20 (6.096)	30 (9.144)	40 (12.192)	50 (15.240)	60 (18.288)	70 (21.336)	80 (24.384)	90 (27.432)	100 (30.480)
1/2 (12.7)	.622 (17.799)	175 (4.96)	120 (3.40)	97 (2.75)	82 (2.32)	73 (2.07)	66 (1.87)	61 (1.73)	57 (1.61)	53 (1.50)	50 (1.42)
3/4 (19.05)	.824 (20.930)	360 (10.19)	250 (7.08)	200 (5.66)	170 (4.81)	151 (4.28)	138 (3.91)	125 (3.54)	118 (3.34)	110 (3.11)	103 (2.92)
1 (25.4)	1.049 (26.645)	680 (19.25)	465 (13.17)	375 (10.62)	320 (9.06)	285 (8.07)	260 (7.36)	240 (6.80)	220 (6.23)	205 (5.80)	195 (5.52)
1-1/4 (31.75)	1.380 (35.052)	1400 (39.64)	950 (26.90)	770 (21.80)	660 (18.69)	580 (16.42)	530 (15.01)	490 (13.87)	460 (13.03)	430 (12.18)	400 (11.33)
1-1/2 (38.1)	1.610 (40.894)	2100 (59.46)	1460 (41.34)	1180 (33.41)	990 (28.03)	900 (25.48)	810 (22.94)	750 (21.24)	690 (19.54)	650 (18.41)	620 (17.56)
2 (50.8)	2.067 (52.502)	3950 (111.85)	2750 (77.87)	2200 (62.30)	1900 (53.80)	1680 (47.57)	1520 (43.04)	1400 (39.64)	1300 (36.81)	1220 (34.55)	1150 (32.56)
2-1/2 (63.5)	2.469 (67.713)	6300 (178.39)	4350 (123.17)	3520 (99.67)	3000 (84.95)	2650 (75.04)	2400 (67.96)	2250 (63.71)	2050 (58.05)	1950 (55.22)	1850 (52.38)
3 (76.2)	3.068 (77.927)	11000 (311.48)	7700 (218.03)	6250 (176.98)	5300 (150.07)	4750 (134.50)	4300 (121.76)	3900 (110.43)	3700 (104.77)	3450 (97.69)	3250 (92.03)

NOTE: Capacity given in cubic feet of gas per hour (kilo liters of gas per hour) and based on 0.60 specific gravity gas.

Table 10.

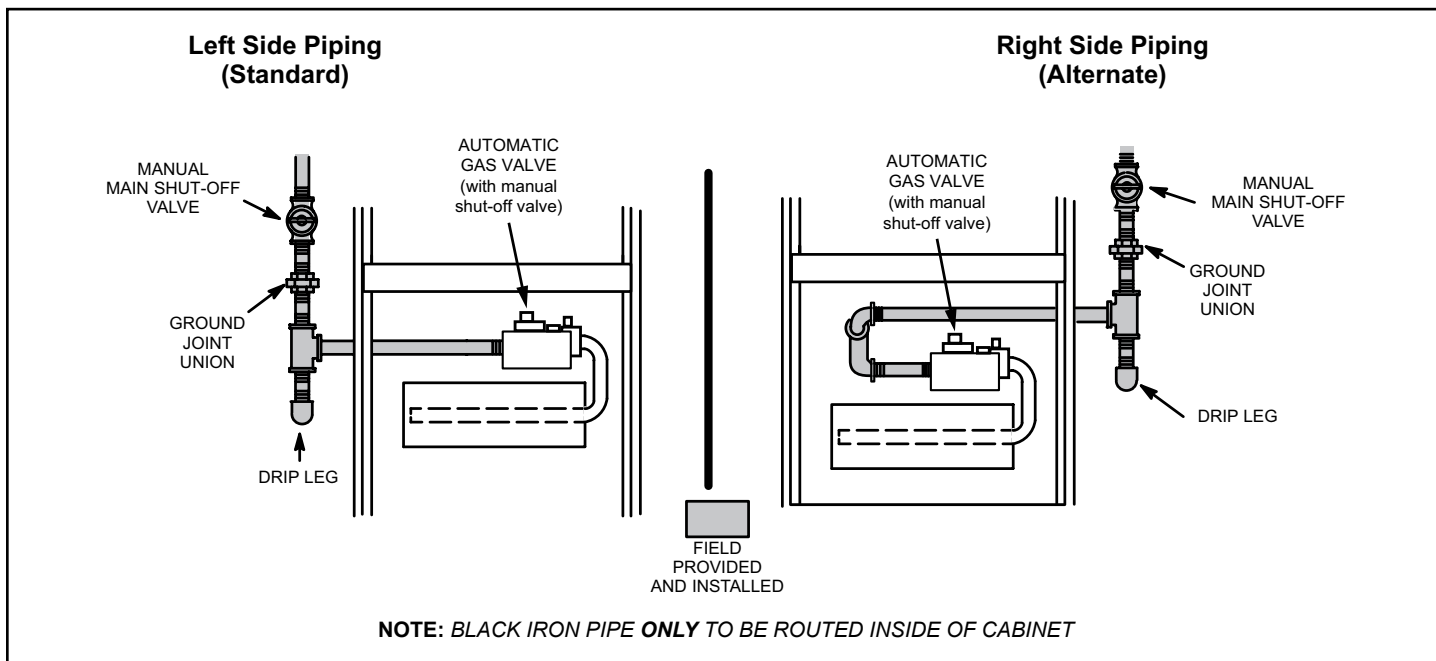

Figure 18.

Leak Check

After gas piping is completed, carefully check all piping connections (factory and field installed) for gas leaks. Use a leak detecting solution or other preferred means.

NOTE: *If emergency shutoff is necessary, shut off the main manual gas valve and disconnect the main power to the furnace. The installer should properly label these devices.*

CAUTION

Some soaps used for leak detection are corrosive to certain metals. Carefully rinse piping thoroughly after leak test has been completed. Do not use matches, candles, flame or other sources of ignition to check for gas leaks.

The furnace must be isolated by closing its individual manual shut-off valve and disconnecting from the gas supply system the during any pressure testing of the gas supply system at pressures less than or equal to 1/2 psig (3.48 kPa, 14 inches w.c.).

IMPORTANT

When testing pressure of gas lines, gas valve must be disconnected and isolated. See Figure 19. Gas valves can be damaged if subjected to pressures greater than 1/2 psig (3.48 kPa, 14 inches w.c.).

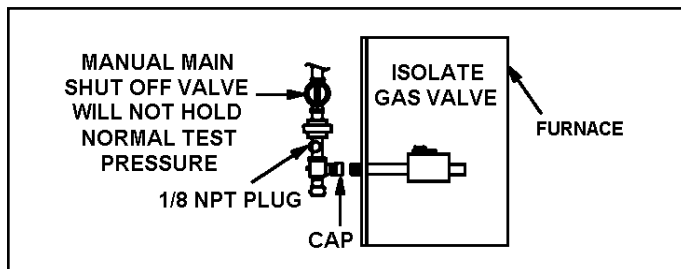

Figure 19.

Electrical

ELECTROSTATIC DISCHARGE (ESD)

Precautions and Procedures

CAUTION

Electrostatic discharge can affect electronic components. Take precautions during furnace installation and service to protect the furnace's electronic controls. Precautions will help to avoid control exposure to electrostatic discharge by putting the furnace, the control and the technician at the same electrostatic potential. Neutralize electrostatic charge by touching hand and all tools on an unpainted unit surface, such as the gas valve or blower deck, before performing any service procedure.

The unit is equipped with a field make-up box on the left hand side of the cabinet. The make-up box may be moved to the right side of the furnace to facilitate installation. If the make-up box is moved to the right side, clip the wire ties that bundle the wires together. The excess wire must be pulled into the blower compartment. Secure the excess wire to the existing harness to protect it from damage.

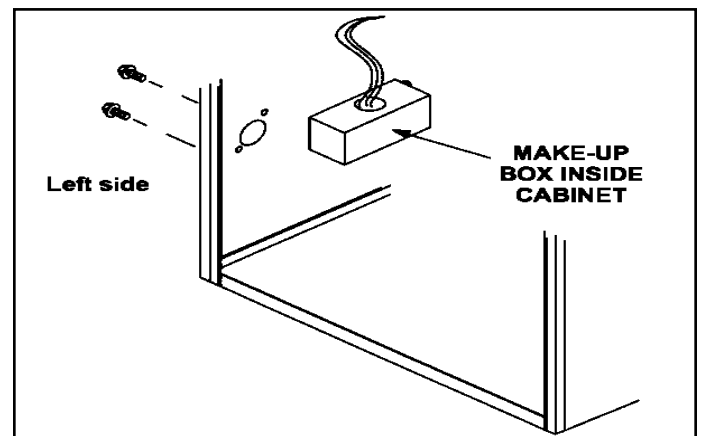

Figure 20. Interior Make-Up Box Installation

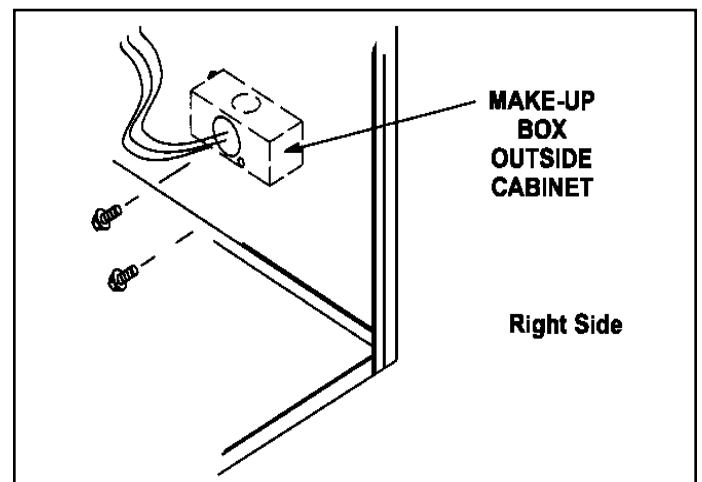

Figure 21. Interior Make-Up Box Installation

Refer to Figure 23 for schematic wiring diagram and troubleshooting and Figure 24 for field wiring.

The power supply wiring must meet Class I restrictions. Protected by either a fuse or circuit breaker, select circuit protection and wire size according to unit nameplate.

NOTE: Unit nameplate states maximum current draw. Maximum over current protection allowed is 15 AMP.

Holes are on both sides of the furnace cabinet to facilitate wiring.

Install a separate (properly sized) disconnect switch near the furnace so that power can be turned off for servicing.

Before connecting the thermostat, check to make sure the wires will be long enough for servicing at a later date. Make sure that thermostat wire is long enough to facilitate future removal of blower for service.

Complete the wiring connections to the equipment. Use the provided unit wiring diagram and the field wiring diagram shown in Figure 24. Use 18 gauge wire or larger that is suitable for Class II rating for thermostat connections.

Electrically ground the unit according to local codes or, in the absence of local codes, according to the current National Electric Code (ANSI/NFPA No. 70). A green ground wire is provided in the field make-up box.

NOTE: This furnace contains electronic components that are polarity sensitive. Make sure that the furnace is wired correctly and is properly grounded.

Accessory Terminals

One line voltage “ACC” 1/4” spade terminal is provided on the furnace integrated control. See Figure 25 for integrated control configuration. This terminal is energized when the indoor blower is operating. Any accessory rated up to one amp can be connected to this terminal with the neutral leg of the circuit being connected to one of the provided neutral terminals. If an accessory rated at greater than one amp is connected to this terminal, it is necessary to use an external relay.

One line voltage “HUM” 1/4” spade terminal is provided on the furnace integrated control. See Figure 25 for integrated control configuration. This terminal is energized in the heating mode when the combustion air inducer is operating. Any humidifier rated up to one amp can be connected to this terminal with the neutral leg of the circuit being connected to one of the provided neutral terminals. If a humidifier rated at greater than one amp is connected to this terminal, it is necessary to use an external relay.

One 24V “H” 1/4” spade terminal is provided on the furnace control board. Any humidifier rated up to 0.5 amp can be connected to this terminal with the ground leg of the circuit

connected to ground or the “C” terminal. See Figure 25 for control board configuration. This terminal is energized in the heating mode when the combustion air inducer is operating.

Generator Use - Voltage Requirements

The following requirements must be kept in mind when specifying a generator for use with this equipment:

- The furnace requires 120 volts \pm 10% (Range: 108 volts to 132 volts).
- The furnace operates at 60 Hz \pm 5% (Range: 57 Hz to 63 Hz).
- The furnace integrated control requires both polarity and proper ground. Both polarity and proper grounding should be checked before attempting to operate the furnace on either permanent or temporary power.
- Generator should have a wave form distortion of less than 5% RHO.

Thermostat

Install the room thermostat according to the instructions provided with the thermostat. See Figure 22 for thermostat designations. If the furnace is being matched with a heat pump, refer to the FM21 installation instruction or appropriate dual fuel thermostat instructions.

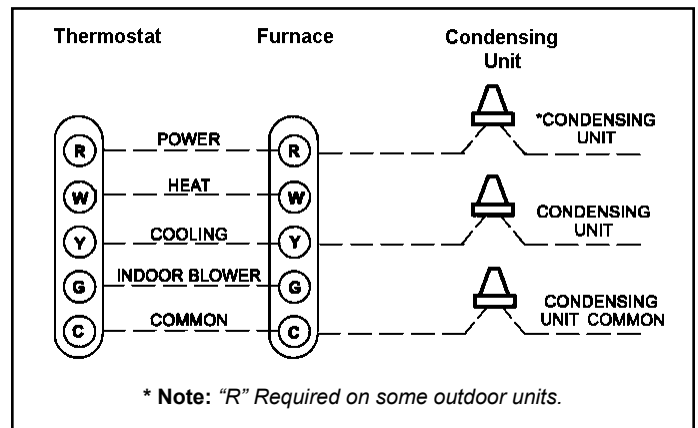

Figure 22. Condensing Unit Thermostat Designations (Refer to Specific Thermostat and Outdoor Unit)

Indoor Blower Speeds

1. When the thermostat is set to “FAN ON,” the indoor blower will run continuously on the fan speed when there is no cooling or heating demand.
2. When the unit is running in the heating mode, the indoor blower will run on the heating speed.
3. When there is a cooling demand, the indoor blower will run on the cooling speed.

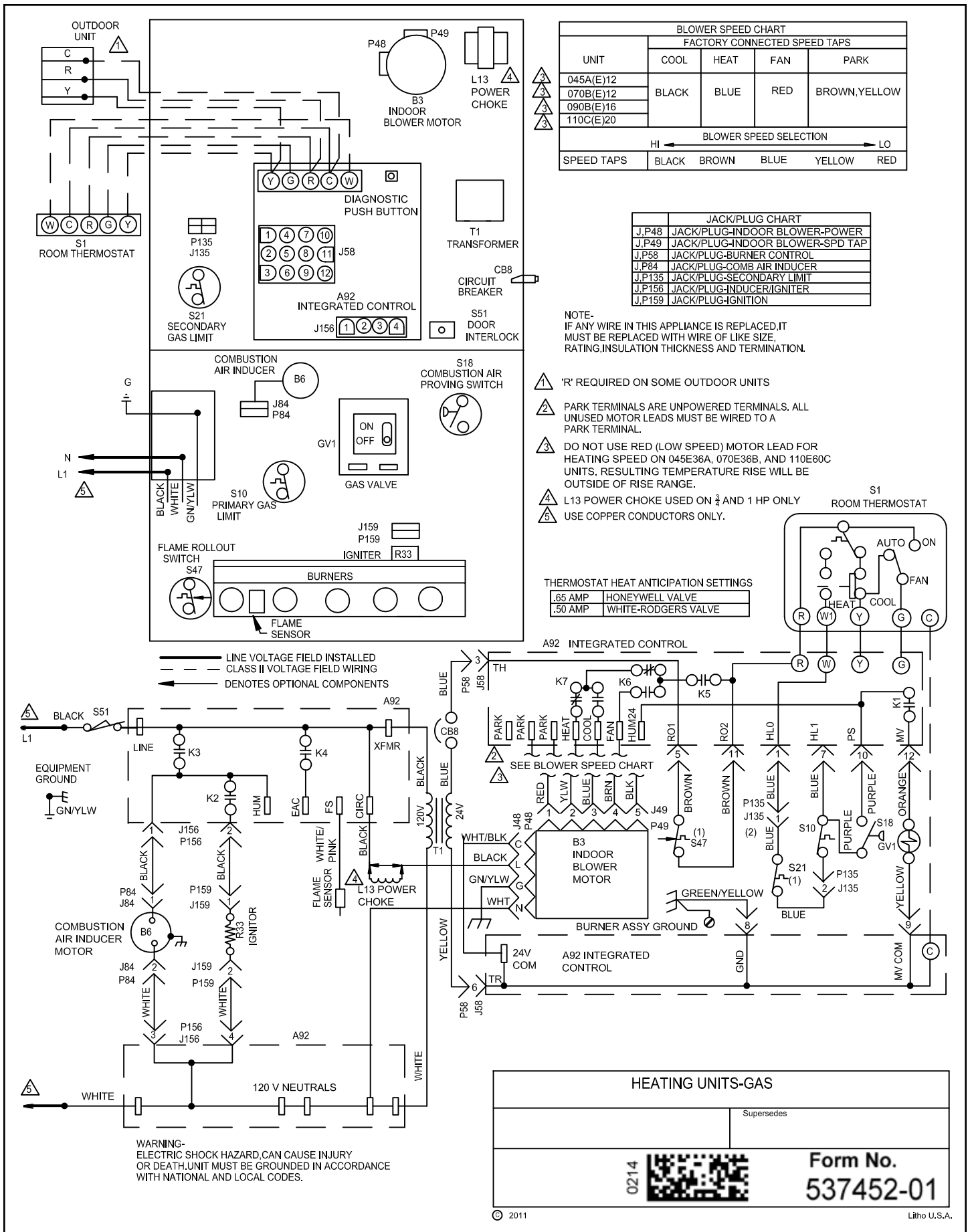

Figure 23. Wiring Diagram

Unit Start-Up

FOR YOUR SAFETY READ BEFORE LIGHTING UNIT

⚠ WARNING

Do not use this furnace if any part have been underwater. Immediately call a licensed professional service technician (or equivalent) to inspect the furnace and to replace any part of the control system and any gas control which has been underwater.

⚠ WARNING

If overheating occurs or if gas supply fails to shut off, shut off the manual gas valve to the appliance before shutting off electrical supply.

⚠ WARNING

Before attempting to perform any service or maintenance, turn the electrical power to unit OFF at disconnect switch.

BEFORE LIGHTING smell all around the appliance area for gas. Be sure to smell next to the floor because some gas is heavier than air and will settle on the floor.

The gas valve on this unit will be equipped with a gas control switch. Use only your hand to move the switch. Never use tools. If the switch will not turn or if the control switch will not move by hand, do not try to repair it.

Placing the Furnace into Operation

These units are equipped with an automatic ignition system. Do not attempt to manually light burners on these furnaces. Each time the thermostat calls for heat, the burners will automatically light. The ignitor does not get hot when there is no call for heat on units with an automatic ignition system.

⚠ WARNING

If you do not follow these instructions exactly, a fire or explosion may result causing property damage, personal injury or death.

Gas Valve Operation

See Figure 26

1. **STOP!** Read the safety information at the beginning of this section.

2. Set the thermostat to the lowest setting.
3. Turn off all electrical power to the unit.
4. This furnace is equipped with an ignition device which automatically lights the burners. Do not try to light the burners by hand.
5. Remove the upper access panel.
6. Move switch on gas valve to OFF. Do not force. See Figure 26.
7. Wait five minutes to clear out any gas. If you then smell gas, **STOP!** Immediately call your gas supplier from a neighbor's phone. Follow the gas supplier's instructions. If you do not smell gas go to next step.

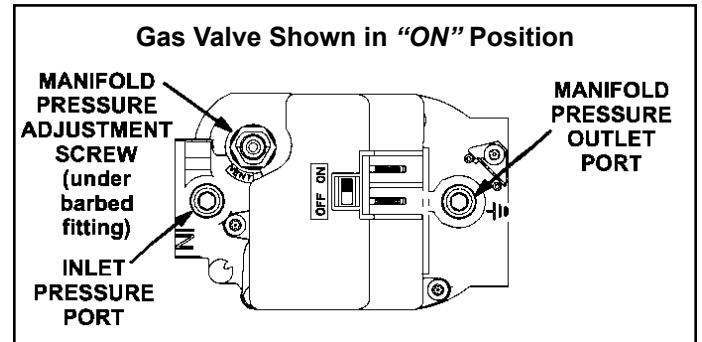

Figure 26.

8. Move switch on gas valve to ON. Do not force. See Figure 26.
 9. Replace the upper access panel.
 10. Turn on all electrical power to the unit.
 11. Set the thermostat to desired setting.
- NOTE:** When unit is initially started, steps 1 through 11 may need to be repeated to purge air from gas line.
12. If the appliance will not operate, follow the instructions "Turning Off Gas to Unit" and call your service technician or gas supplier.

Turning Off Gas to Unit

1. Set the thermostat to the lowest setting.
2. Turn OFF all electrical power to the unit if service is to be performed.
3. Remove the upper access panel.
4. Move switch on gas valve to OFF. Do not force.
5. Replace the upper access panel.

Failure To Operate

If the unit fails to operate, check the following:

1. Is the thermostat calling for heat?
2. Are access panels securely in place?
3. Is the main disconnect switch closed?
4. Is there a blown fuse or tripped circuit breaker?
5. Is the filter dirty or plugged? Dirty or plugged filters will cause the limit control to shut the unit off.

6. Is gas turned on at the meter?
7. Is the manual main shut-off valve open?
8. Is the internal manual shut-off valve open?
9. Is the unit ignition system in lock out? If the unit locks out again, call the service technician to inspect the unit for blockages.
10. Is pressure switch closed? Obstructed flue will cause unit to shut off at pressure switch. Check flue and outlet for blockages.
11. Are flame rollout switches tripped? If flame rollout switches are tripped, call the service technician for inspection.

Heating Sequence of Operation

See Figure 27

1. When thermostat calls for heat, combustion air blower starts.
2. Combustion air pressure switch proves blower operation. Switch is factory set and requires no adjustment.
3. After a 15 second pre-purge, the hot surface ignitor energizes.
4. After a 20 second ignitor warm-up period, the gas valve solenoid opens. A 4 second trial for ignition period begins.
5. Gas is ignited, flame sensor proves the flame, and the combustion process continues.
6. If flame is not detected after first ignition trial, the ignition control will repeat steps 3 and 4 four more times before locking out the gas valve. The ignition control will then automatically repeat steps 1 through 6 after 60 minutes.
7. To interrupt the 60 minute, move thermostat from "Heat" to "OFF" then back to "Heat." Heating sequence then restarts at step 1.

Gas Pressure Adjustment Gas Flow (Approximate)

Gas Meter Clocking Chart				
Capacity	Seconds for One Revolution			
	Natural		LP	
	1 cu ft Dial	2 cu ft Dial	1 cu ft Dial	2 cu ft Dial
-045	80	160	200	400
-070	55	110	136	272
-090	41	82	102	204
-110	33	66	82	164
-135	27	54	68	136
Natural - 1000 btu/cu ft			LP - 2500 btu/cu ft	

Table 11.

Furnace should operate at least 5 minutes before checking gas flow. Determine time in seconds for two revolutions of gas through the meter. (Two revolutions assures a more accurate time.) Divide by two and compare to time in Table 11 above. If manifold pressure matches Table 13 and rate is incorrect, check gas orifices for proper size and restriction. Remove temporary gas meter if installed.

NOTE: To obtain accurate reading, shut off all other gas appliances connected to meter.

Supply Pressure Measurement

A threaded plug on the inlet side of the gas valve provides access to the supply pressure tap. Remove the threaded plug, install a field provided barbed fitting and connect a manometer to measure supply pressure. See Table 13 for proper line pressure. Replace the threaded plug after measurements have been taken.

Manifold Pressure Measurement

1. Remove the threaded plug from the outlet side of the gas valve and install a field provided barbed fitting. Connect to a manometer to measure manifold pressure.
2. Start unit and allow 5 minutes for unit to reach steady state.

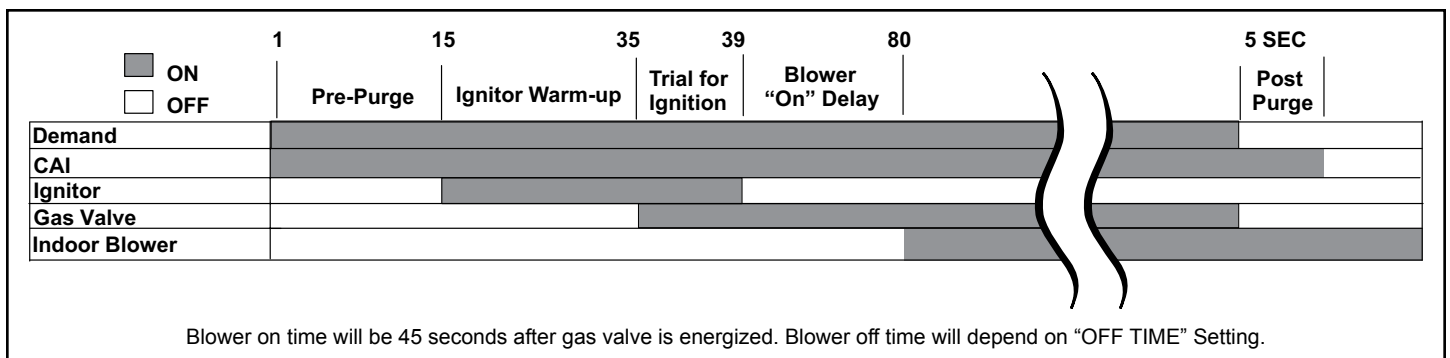

Figure 27. Heating Sequence of Operation

- While waiting for the unit to stabilize, observe the flame. Flame should be stable and should not lift from burner. Natural gas should burn blue.
- After allowing unit to stabilize for 5 minutes, record manifold pressure and compare to value given in Table 13.

NOTE: Shut unit off and remove manometer as soon as an accurate reading has been obtained. Take care to remove barbed fitting and replace threaded plug.

Proper Combustion

Furnace should operate a minimum 15 minutes with correct manifold pressure and gas flow rate before checking combustion. Take combustion sample beyond the flue out let and compare to the tables below. The maximum carbon monoxide reading should not exceed 100 ppm.

Capacity	CO ² % for Nat.	CO ² % for LP
-045	7.2 - 7.8	7.5 - 9.0
-070		
-090		
-110		
-135		

Table 12.

High Altitude

The manifold pressure may require adjustment to ensure proper combustion at higher altitudes. Refer to Table 13 for manifold pressure and pressure switch change.

Other Unit Adjustments

Primary and Secondary Limits

The primary limit is located on the heating compartment vestibule panel. The secondary limits (if equipped) are located in the blower compartment, attached to the back side of the blower. These auto reset limits are factory set and require no adjustment.

Flame Rollout Switches

This manually reset switches are located on the front of the burner box.

Pressure Switch

The pressure switch is located in the heating compartment adjacent to the combustion air inducer. The switch checks for proper combustion air inducer operation before allowing ignition trial. The switch is factory set and requires no adjustment.

Temperature Rise

After the furnace has been started, and supply and return air temperatures have been allowed to stabilize, check the temperature rise. If necessary, adjust the blower speed to maintain the temperature rise within the range shown on the unit nameplate. Increase the blower speed to decrease the temperature. Decrease the blower speed to increase the temperature rise. Failure to adjust the temperature rise may cause erratic limit operation.

Capacity	Gas	Line Pressure (in. w.c.)		0 - 2,000 ft.			2,000 - 4,500 ft.			4,501 - 7,500 ft.			7,501 - 10,000 ft.			
		Min.	Max.	Orifice Size (in)	Manifold Pressure (in w.c.)	Pressure Switch	Orifice Size (in)	Manifold Pressure (in w.c.)	Pressure Switch	Orifice Size (in)	Manifold Pressure (in w.c.)	Pressure Switch	Orifice Size (in)	Manifold Pressure (in w.c.)	Pressure Switch	
045	Nat	4.5	10.0	No Change 0.0625"	3.5	No Change	No Change 0.0625"	3.5	No Change	No Change 0.0625"	3.5	No Change	51W01 0.0550"	3.5	74W89 -0.55" w.c.	
	LP/ Propane	11.0	13.0	11K50 0.034"	10.0		11K50 0.034"	10.0		11K50 0.034"	10.0		11K45 0.032"	10.0		
070	Nat	4.5	10.0	No Change 0.0625"	3.5		No Change 0.0625"	3.5		No Change 0.0625"	3.3		51W01 0.0550"	3.5		
	LP/ Propane	11.0	13.0	11K50 0.034"	10.0		11K50 0.034"	10.0		11K50 0.034"	10.0		11K45 0.032"	10.0		
090	Nat	4.5	10.0	No Change 0.0625"	3.5		No Change 0.0625"	3.5		No Change 0.0625"	3.3		51W01 0.0550"	3.5		
	LP/ Propane	11.0	13.0	11K50 0.034"	10.0		11K50 0.034"	10.0		11K50 0.034"	10.0		11K45 0.032"	10.0		
110	Nat	4.5	10.0	No Change 0.0625"	3.5		No Change 0.0625"	3.5		No Change 0.0625"	3.3		74W60 -0.60" w.c.	51W01 0.0550"		3.5
	LP/ Propane	11.0	13.0	11K50 0.034"	10.0		11K50 0.034"	10.0		11K50 0.034"	10.0		74W60 -0.60" w.c.	11K45 0.032"		10.0

NOTE: A natural to L.P. propane gas changeover kit is necessary to convert this unit. Refer to the changeover kit installation instruction for the conversion procedure.

NOTE: For Altitudes of 7501' - 10,000' call Lennox Technical Support Product Applications.

Table 13. Manifold Pressure Settings and Pressure Switch

⚠ IMPORTANT

For Safety, shut unit off and remove manometer as soon as an accurate reading has been obtained. Take care to replace pressure tap plug.

Fan Control

The fan on time of 45 seconds is not adjustable. The heat fan off delay (amount of time that the blower operates after the heat demand has been satisfied) may be adjusted by changing the jumper position across the five pins on the integrated control. The unit is shipped with a factory fan off delay setting of 90 seconds. The fan off delay affects comfort and is adjustable to satisfy individual applications. Adjust the fan off delay to achieve a supply air temperature between 90° and 110° F at the moment that the blower is de-energized. Longer off delay settings provide lower return air temperatures; shorter settings provide higher return air temperatures. See Figure 28.

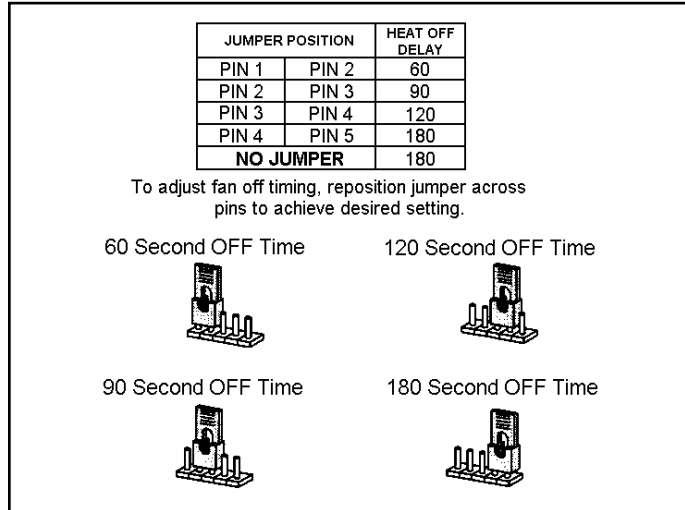

Figure 28. Heat Fan Off Time in Seconds

Constant Torque Motor

These units are equipped with a permanent magnetic indoor blower motor that provides constant torque. The motor has five speed taps all referenced to the same signal common. Each tap requires 24 volts to be energize.

Thermostat Heat Anticipation

Set the heat anticipator setting (if adjustable) according to the amp draw listed on the wiring diagram that is attached to the unit.

NOTE: Do not secure the electrical conduit directly to the air ducts or structure.

Electrical

1. Check all wiring for loose connections.
2. Check for the correct voltage at the furnace (furnace operating). Correct voltage is 120VAC \pm 10%.
3. Check amp-draw on the blower motor with inner blower panel in place.

Unit Nameplate _____ Actual _____

Blower Speeds

Follow the steps below to change the blower speeds.

1. Turn off electrical power to furnace.
2. Remove blower access panel.
3. Disconnect existing speed tap at integrated control speed terminal.
NOTE: Termination of any unused motor leads must be insulated.
4. Place unused blower speed tap on integrated control "PARK" terminal or insulate.
5. Refer to blower speed selection chart on unit wiring diagram for desired heating or cooling speed. See Blower performance data.
6. Connect selected speed tap at integrated control speed terminal.
7. Resecure blower access panel.
8. Turn on electrical power to furnace.
9. Recheck temperature rise.

Electronic Ignition

The integrated control has an added feature of an internal control. The feature serves as an automatic reset device for integrated control lockout caused by ignition failure. This type of lockout is usually due to low gas line pressure. After one hour of continuous thermostat demand for heat, the control will break and remake thermostat demand to the furnace and automatically reset the integrated control to begin the ignition sequence.

Blower Performance

A80DF1E / 80G1DFE 045*A12 Performance (Less Filter)

External Static Pressure in. w.c.	Air Volume / Watts at Various Blower Speeds									
	High		Medium-High		Medium		Medium-Low		Low	
	cfm	watts	cfm	watts	cfm	watts	cfm	watts	cfm	watts
0.00	1430	285	1215	180	1035	120	995	110	930	100
0.10	1400	285	1175	185	995	130	885	100	850	90
0.20	1375	300	1145	200	950	140	840	110	725	85
0.30	1335	315	1120	210	915	145	790	115	665	95
0.40	1320	325	1075	220	870	155	745	125	625	100
0.50	1275	335	1045	230	835	165	715	135	565	105
0.60	1245	345	1000	235	785	170	655	140	520	115
0.70	1215	355	970	245	745	180	605	150	355	130
0.80	1175	365	925	255	695	185	555	155	400	130

A80DF1E / 80G1DFE 070*B12 Performance (Less Filter)

External Static Pressure in. w.c.	Air Volume / Watts at Various Blower Speeds									
	High		Medium-High		Medium		Medium-Low		Low	
	cfm	watts	cfm	watts	cfm	watts	cfm	watts	cfm	watts
0.00	1475	275	1345	170	1225	135	1185	125	1110	105
0.10	1430	290	1275	175	1190	145	1155	135	1005	95
0.20	1400	295	1230	190	1125	160	1110	150	900	100
0.30	1360	310	1205	205	1085	160	1055	155	845	115
0.40	1310	325	1155	210	1050	175	1000	165	790	115
0.50	1280	335	1110	220	985	185	950	180	705	130
0.60	1250	350	1060	235	935	195	865	185	645	135
0.70	1220	355	1000	245	865	205	815	195	590	140
0.80	1165	365	935	250	795	210	750	200	480	145

A80DF1E / 80G1DFE 090*B16 Performance (Less Filter)

External Static Pressure in. w.c.	Air Volume / Watts at Various Blower Speeds									
	High		Medium-High		Medium		Medium-Low		Low	
	cfm	watts	cfm	watts	cfm	watts	cfm	watts	cfm	watts
0.00	1750	385	1550	265	1430	205	1355	185	1195	130
0.10	1725	390	1495	270	1390	220	1320	195	1145	140
0.20	1695	405	1470	285	1340	235	1280	210	1105	145
0.30	1660	415	1425	300	1290	240	1225	215	1040	160
0.40	1615	430	1395	310	1250	255	1185	230	1005	170
0.50	1570	450	1360	325	1210	265	1145	240	945	180
0.60	1545	465	1295	340	1165	280	1085	255	865	185
0.70	N/A	N/A	1265	350	1120	295	1040	265	810	200
0.80	N/A	N/A	1215	365	1080	305	1000	275	755	210

A80DF1E / 80G1DFE 110*C20 Performance (Less Filter)

External Static Pressure in. w.c.	Air Volume / Watts at Various Blower Speeds									
	High		Medium-High		Medium		Medium-Low		Low	
	cfm	watts	cfm	watts	cfm	watts	cfm	watts	cfm	watts
0.00	2410	625	2095	405	1875	295	1700	225	1635	180
0.10	2385	630	2100	410	1830	310	1610	240	1505	190
0.20	2325	650	2010	440	1760	330	1570	255	1375	195
0.30	2280	675	1940	460	1705	340	1500	260	1320	210
0.40	2235	690	1895	475	1635	365	1440	285	1265	225
0.50	2165	710	1845	490	1595	380	1380	300	1200	235
0.60	2125	735	1800	510	1545	390	1320	310	1170	250
0.70	2090	740	1755	530	1510	405	1285	325	1100	260
0.80	2035	760	1700	540	1460	425	1255	345	1030	275

Service

⚠ WARNING

ELECTRICAL SHOCK, FIRE, OR EXPLOSION HAZARD

Failure to follow safety warnings exactly could result in dangerous operation, serious injury, death or property damage.

Improper servicing could result in dangerous operation, serious injury, death, or property damage. Before servicing, disconnect all electrical power to furnace.

When servicing controls, label all wires prior to disconnecting. Take care to reconnect wires correctly. Verify proper operation after servicing.

At the beginning of each heating season, a qualified technician should check the system as follows:

Blower

Check the blower wheel for debris and clean if necessary. The blower motors are pre-lubricated for extended bearing life. No further lubrication is needed.

⚠ WARNING

The blower access panel must be securely in place when the blower and burners are operating. Gas fumes, which could contain carbon monoxide, can be drawn into living space resulting in personal injury or death.

Filters

Filters are installed external to the unit. Filters should be inspected monthly. Clean or replace the filters when necessary to ensure that the furnace operates properly. Replacement filters must be rated for high velocity airflow.

Flue And Chimney

1. Check flue pipe, chimney and all connections for tightness and to make sure there is no blockage.
2. Check unit for proper draft.

Electrical

1. Check all wiring for loose connections.
2. Check for the correct voltage at the furnace (furnace operating). Correct voltage is 120VAC.± 10%.
3. Check amp draw on the blower motor with inner blower panel in place.

Unit Nameplate _____ Actual _____

Cleaning the Heat Exchanger and Burners

NOTE: Use papers or protective covering in front of the furnace during cleaning.

1. Turn off both electrical and gas power supplies to furnace.
2. Remove flue pipe and top cap (some applications top cap can remain) from the unit.
3. Label the wires from gas valve, rollout switches, primary limit switch and make-up box then disconnect them.
4. Remove the screws that secure the combustion air inducer/pressure switch assembly to the collector box. Carefully remove the combustion air inducer to avoid damaging blower gasket. If gasket is damaged, it must be replaced to prevent leakage.
5. Remove the collector box located behind the combustion air inducer. Be careful with the collector box gasket. If the gasket is damaged, it must be replaced to prevent leakage.
6. Disconnect gas supply piping. Remove the screw securing the burner box cover and remove cover. Remove the four screws securing the burner manifold assembly to the vestibule panel and remove the assembly from the unit.

7. Remove screws securing burner box and remove burner box.
8. NOX units only - Remove screw securing NOX insert. Remove NOX insert. See Figure 29.
9. Remove screws from both sides, top and bottom of vestibule panel.
10. Remove heat exchanger. It may be necessary to spread cabinet side to allow more room. If so, remove five screws from the left side or right side of cabinet. See Figure 31.
11. Backwash using steam. Begin from the burner opening on each clam. Steam must not exceed 275° F.
12. To clean burners, run a vacuum cleaner with a soft brush attachment over the face of burners. Visually inspect inside the burners and crossovers for any blockage caused by foreign matter. Remove any blockage. Figure 30 shows burner detail.
13. To clean the combustion air inducer visually inspect and using a wire brush clean where necessary. Use compressed air to clean off debris and any rust.
14. Reinstall heat exchanger in vestibule. (Replace the five screws in the cabinet from step 10 if removed).
15. NOx units only - Replace NOx inserts.
16. Reinstall collector box and combustion air assembly. Reinstall all screws to the collector box and combustion air inducer. Failure to replace all screws may cause leaks. Inspect gaskets for any damage and replace if necessary.
17. Reinstall burner box, manifold assembly and burner box cover.

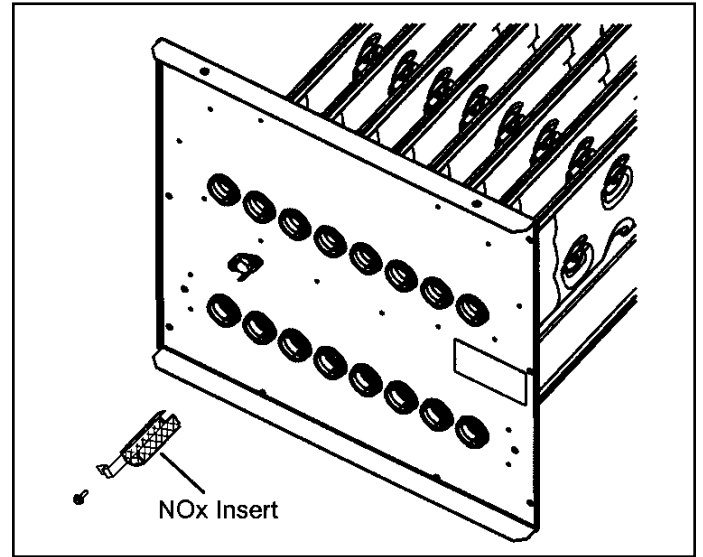

Figure 29. NOx Inserts

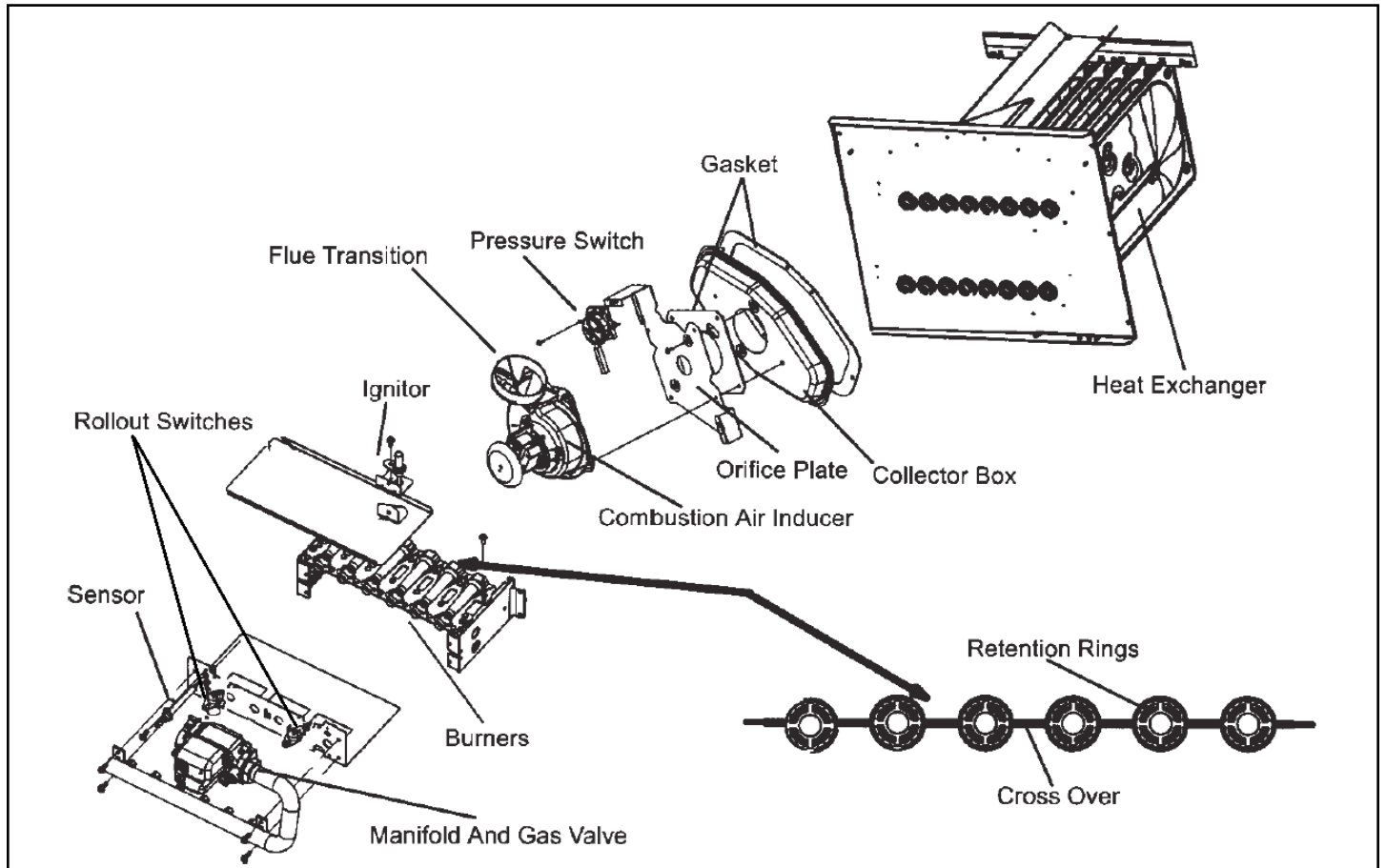

Figure 30. Burner, Combustion Air Inducer Assembly & Heat Exchanger Removal

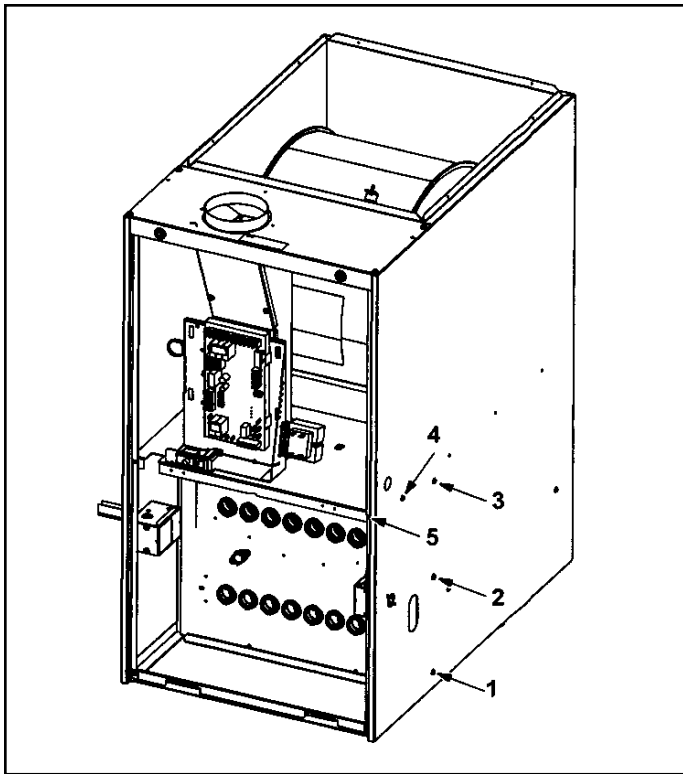

Figure 31. Remove 5 Screws if Necessary (either side of cabinet)

18. Reconnect all wires.
19. Reconnect top cap and vent pipe to combustion air inducer outlet.
20. Reconnect gas supply piping.
21. Turn on power and gas supply to unit.
22. Set thermostat and check for proper operation.
23. Check all piping connections, factory and field, for gas leaks. Use a leak detecting solution or other preferred means.

CAUTION

Some soaps used for leak detection are corrosive to certain metals. Carefully rinse piping thoroughly after leak test has been completed. Do not use matches, candles, flame or other sources of ignition to check for gas leaks.

24. If a leak is detected, shut gas and electricity off and repair leak.
25. Repeat steps 24 and 26 until no leaks are detected.
26. Replace access panel.

Planned Service

The following items should be checked during an annual inspection. Power to the unit must be shut off for the service technician's safety.

Fresh air grilles and louvers (on the unit and in the room where the furnace is installed) - Must be open and unobstructed to provide combustion air.

Burners - Must be inspected for rust, dirt, or signs of water.

Vent pipe - Must be inspected for signs of water, damaged or sagging pipe, or disconnected joints.

Unit appearance - Must be inspected for rust, dirt, signs of water, burnt or damaged wires, or components.

Blower access panel - Must be properly in place and provide a seal between the return air and the room where the furnace is installed.

Return air duct - Must be properly attached and provide an air seal to the unit.

Operating performance - Unit must be observed during operation to monitor proper performance of the unit and the vent system.

Combustion gases - Flue products must be analyzed and compared to the unit specifications.

Problems detected during the inspection may make it necessary to temporarily shut down the furnace until the items can be repaired or replaced.

Instruct the homeowners to pay attention to their furnace. Situations can arise between annual furnace inspections that may result in unsafe operation. For instance, items innocently stored next to the furnace may obstruct the combustion air supply. This could cause incomplete combustion and the production of carbon monoxide gas.

-02 Integrated Control LED Codes

Red LED Flash Code	Diagnostic Codes / Status of Furnace
LED Off	No power to control or control hardware fault detected
Heartbeat ¹	Control powered - displayed during all modes of operation if no errors are detected
1 Flash	Reverse line voltage polarity
2 Flashes	Improper earth ground
3 Flashes	Burner failed to light, or lost flame during heat demand
4 Flashes	Low flame signal - check flame sensor
5 Flashes	Watchguard - burner failed to light, exceeded maximum number of retries or recycles
6 Flashes	Not used
7 Flashes	Primary or Secondary limit open or watchguard mode - limit switch open longer than 3 minutes
8 Flashes	Rollout switch open
9 Flashes	Pressure switch failed to close or opened during heat demand
10 Flashes	Watchguard - Pressure switch opened 5 times during one heat demand
11 Flashes	Pressure switch stuck closed prior to activation of combustion air inducer
12 Flashes	Flame sensed without gas valve energized
13 Flashes	Low line voltage

¹ A "heartbeat" is indicated by a "slow flash" - 1 sec on 1 sec off, repeating

NOTE: Last 10 error codes are stored in memory, including when power is shut off to the unit. To recall, press and release button. Most recent will be displayed first, LED off for 3 sec, then next error code is displayed, etc. To clear error codes, depress and hold button longer than 5 seconds.

Table 14. Diagnostic Codes for -02 Control

-03 Integrated Control LED Codes

Red LED Flash Code²	Diagnostic Codes / Status of Furnace
LED Off	No power to control or control hardware fault detected
Heartbeat ¹	Normal operation - idle, continuous fan, cool
Continuous Rapid Flash	Call for heat / burner operation
1 Flash	Reverse line voltage polarity
2 Flashes	Improper earth ground
3 Flashes	Burner failed to light, or lost flame during heat demand
4 Flashes	Low flame signal - check flame sensor
5 Flashes	Watchguard - burner failed to light, exceeded maximum number of retries or recycles
6 Flashes	Not used
7 Flashes	Primary or Secondary limit open or watchguard mode - limit switch open longer than 3 minutes
8 Flashes	Rollout switch open
9 Flashes	Pressure switch failed to close or opened during heat demand
10 Flashes	Watchguard - Pressure switch opened 5 times during one heat demand
11 Flashes	Pressure switch stuck closed prior to activation of combustion air inducer
12 Flashes	Flame sensed without gas valve energized
13 Flashes	Low line voltage

¹ A "heartbeat" is indicated by a "slow flash" - 1 sec on 1 sec off, repeating

² Error codes are indicated by a "rapid flash" - the LED flashes X times at 1/2 sec on, 1/2 sec off, remains off for 3 sec, then repeats

NOTE: Last 10 error codes are stored in memory, including when power is shut off to the unit. To recall, press and release button. Most recent will be displayed first, LED off for 3 sec, then next error code is displayed, etc. To clear error codes, depress and hold button longer than 5 seconds.

Table 15. Diagnostic Codes for -03 Control

Repair Parts List

The following repair parts are available through independent Allied Air dealers. When ordering parts, include the complete furnace model number listed on the CSA International nameplate — Example: A801DF045JP24A-01. All service must be performed by a licensed professional installer (or equivalent), service agency, or gas supplier.

Cabinet Parts

- Upper access panel
- Blower panel
- Top cap

Control Panel

- Parts Transformer
- Integrated control
- Door interlock switch
- Circuit breaker

Blower Parts

- Blower wheel
- Blower housing
- Motor
- Motor mounting frame
- Motor capacitor
- Blower housing cutoff plate

Heating Parts

- Flame sensor
- Heat exchanger assembly
- Gas manifold
- Combustion air inducer
- Gas valve
- Main burner cluster
- Main burner orifices
- Pressure switch
- Ignitor
- Primary limit control
- Flame rollout switch
- Secondary limit

Requirements for Commonwealth of Massachusetts

Modifications to NFPA-54, Chapter 10

Revise NFPA-54 section 10.8.3 to add the following requirements:

For all side wall, horizontally vented, gas-fueled equipment installed in every dwelling, building or structure used in whole or in part for residential purposes, including those owned or operated by the Commonwealth and where the side wall exhaust vent termination is less than seven (7) feet above the finished grade in the area of the venting, including but not limited to decks and porches, the following requirements shall be satisfied:

1. **INSTALLATION OF CARBON MONOXIDE DETECTORS.** At the time of installation of the side wall, horizontally vented, gas-fueled equipment, the installing plumber or gas fitter shall observe that a hard-wired carbon monoxide detector with an alarm and battery backup is installed on the floor level where the gas equipment is to be installed. In addition, the installing plumber or gas fitter shall observe that a battery-operated or hard-wired carbon monoxide detector with an alarm is installed on each additional level of the dwelling, building or structure served by the side wall, horizontally vented, gas-fueled equipment. It shall be the responsibility of the property owner to secure the services of qualified licensed professionals for the installation of hard-wired carbon monoxide detectors.
 - a. In the event that the side wall, horizontally vented, gas-fueled equipment is installed in a crawl space or an attic, the hard-wired carbon monoxide detector with alarm and battery backup may be installed on the next adjacent floor level.
 - b. In the event that the requirements of this subdivision cannot be met at the time of completion of installation, the owner shall have a period of thirty (30) days to comply with the above requirements; provided, however, that during said thirty (30) day period, a battery-operated carbon monoxide detector with an alarm shall be installed.
2. **APPROVED CARBON MONOXIDE DETECTORS.** Each carbon monoxide detector as required in accordance with the above provisions shall comply with NFPA 720 and be ANSI/UL 2034 listed and IAS certified.
3. **SIGNAGE.** A metal or plastic identification plate shall be permanently mounted to the exterior of the building at a minimum height of eight (8) feet above grade directly in line with the exhaust vent terminal for the horizontally vented, gas-fueled heating appliance or equipment. The sign shall read, in print size no less than one-half (1/2) inch in size, **"GAS VENT DIRECTLY BELOW. KEEP CLEAR OF ALL OBSTRUCTIONS."**

4. **INSPECTION.** The state or local gas inspector of the side wall, horizontally vented, gas-fueled equipment shall not approve the installation unless, upon inspection, the inspector observes carbon monoxide detectors and signage installed in accordance with the provisions of 248 CMR 5.08(2)(a) 1 through 4.

EXEMPTIONS: The following equipment is exempt from 24 CMR 5.08(2)(a) 1 through 4:

1. The equipment listed in Chapter 10 entitled "Equipment Not Required to Be Vented" in the most current edition of NFPA 54 as adopted by the Board; and
2. Product Approved side wall, horizontally vented, gas-fueled equipment installed in a room or structure separate from the dwelling, building or structure used in whole or in part for residential purposes.

MANUFACTURER REQUIREMENTS - GAS EQUIPMENT VENTING SYSTEM PROVIDED.

When the manufacturer of Product Approved side wall, horizontally vented, gas-fueled equipment provides a venting system design or venting system components with the equipment, the instructions provided by the manufacturer for installation of the equipment and the venting system shall include:

1. Detailed instructions for the installation of the venting system design or the venting system components: and
2. A complete parts list for the venting system design or venting system.

MANUFACTURER REQUIREMENTS - GAS EQUIPMENT VENTING SYSTEM NOT PROVIDED.

When the manufacturer of Product Approved sidewall, horizontally vented, gas-fueled equipment does not provide the parts for venting the flue gases, but identifies "special venting systems," the following requirements shall be satisfied by the manufacturer:

1. The referenced "special venting system" instructions shall be included with the appliance or equipment installation instructions; and
2. The "special venting systems" shall be Product Approved by the Board, and the instructions for that system shall include a parts list and detailed installation instructions.

A copy of all installation instructions for all Product Approved side wall, horizontally vented, gas-fueled equipment, all venting instructions, all parts lists for venting instructions, and/or all venting design instructions shall remain with the appliance or equipment at the completion of the installation.